

BUV48, BUV48A NPN SILICON POWER TRANSISTORS

Copyright © 1997, Power Innovations Limited, UK

AUGUST 1978 - REVISED MARCH 1997

- Rugged Triple-Diffused Planar Construction
- 15 A Continuous Collector Current
- 1000 Volt Blocking Capability

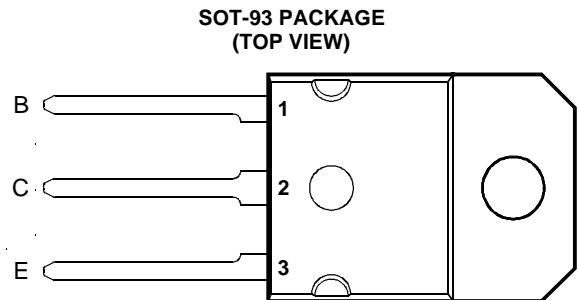

Pin 2 is in electrical contact with the mounting base.

MDTRAA

absolute maximum ratings at 25°C case temperature (unless otherwise noted)

RATING		SYMBOL	VALUE	UNIT
Collector-emitter voltage ($V_{BE} = 0$ V)	BUV48	V_{CES}	850	V
	BUV48A		1000	
Collector-emitter voltage ($R_{BE} = 10 \Omega$)	BUV48	V_{CER}	850	V
	BUV48A		1000	
Collector-emitter voltage ($I_B = 0$)	BUV48	V_{CEO}	400	V
	BUV48A		450	
Continuous collector current		I_C	15	A
Peak collector current (see Note 1)		I_{CM}	30	A
Continuous base current		I_B	4	A
Peak base current		I_{BM}	20	A
Non repetitive accidental peak surge current		I_{CSM}	55	A
Continuous device dissipation at (or below) 25°C case temperature		P_{tot}	125	W
Operating junction temperature range		T_j	-65 to +150	°C
Storage temperature range		T_{stg}	-65 to +150	°C

NOTE 1: This value applies for $t_p \leq 2$ ms, duty cycle $\leq 2\%$.

PRODUCT INFORMATION

Information is current as of publication date. Products conform to specifications in accordance with the terms of Power Innovations standard warranty. Production processing does not necessarily include testing of all parameters.

BUV48, BUV48A

NPN SILICON POWER TRANSISTORS

AUGUST 1978 - REVISED MARCH 1997

electrical characteristics at 25°C case temperature (unless otherwise noted)

PARAMETER	TEST CONDITIONS			MIN	TYP	MAX	UNIT
$V_{CEO(sus)}$ Collector-emitter sustaining voltage	$I_C = 200 \text{ mA}$	$L = 25 \text{ mH}$	(see Note 2)	400 450			V
I_{CES} Collector-emitter cut-off current	$V_{CE} = 850 \text{ V}$	$V_{BE} = 0$				0.2	mA
	$V_{CE} = 1000 \text{ V}$	$V_{BE} = 0$				0.2	
	$V_{CE} = 850 \text{ V}$	$V_{BE} = 0$	$T_C = 125^\circ\text{C}$			2.0	
	$V_{CE} = 1000 \text{ V}$	$V_{BE} = 0$	$T_C = 125^\circ\text{C}$			2.0	
I_{CER} Collector-emitter cut-off current	$V_{CE} = 850 \text{ V}$	$R_{BE} = 10 \Omega$				0.5	mA
	$V_{CE} = 1000 \text{ V}$	$R_{BE} = 10 \Omega$				0.5	
	$V_{CE} = 850 \text{ V}$	$R_{BE} = 10 \Omega$	$T_C = 125^\circ\text{C}$			4.0	
	$V_{CE} = 1000 \text{ V}$	$R_{BE} = 10 \Omega$	$T_C = 125^\circ\text{C}$			4.0	
I_{EBO} Emitter cut-off current	$V_{EB} = 5 \text{ V}$	$I_C = 0$			1	mA	
V_{EBO} Emitter-base breakdown voltage	$I_E = 50 \text{ mA}$	$I_C = 0$		7	30	V	
$V_{CE(sat)}$ Collector-emitter saturation voltage	$I_B = 2 \text{ A}$	$I_C = 10 \text{ A}$				1.5	V
	$I_B = 3 \text{ A}$	$I_C = 15 \text{ A}$	(see Notes 3 and 4)			5.0	
	$I_B = 1.6 \text{ A}$	$I_C = 8 \text{ A}$				1.5	
	$I_B = 2.4 \text{ A}$	$I_C = 12 \text{ A}$				5.0	
$V_{BE(sat)}$ Base-emitter saturation voltage	$I_B = 2 \text{ A}$	$I_C = 10 \text{ A}$				1.6	V
	$I_B = 1.6 \text{ A}$	$I_C = 8 \text{ A}$	(see Notes 3 and 4)			1.6	
f_t Current gain bandwidth product	$V_{CE} = 10 \text{ V}$	$I_C = 0.5 \text{ A}$	$f = 1 \text{ MHz}$		10		MHz
C_{ob} Output capacitance	$V_{CB} = 20 \text{ V}$	$I_C = 0$	$f = 1 \text{ MHz}$		150		pF

NOTES: 2. Inductive loop switching measurement.

3. These parameters must be measured using pulse techniques, $t_p = 300 \mu\text{s}$, duty cycle $\leq 2\%$.

4. These parameters must be measured using voltage-sensing contacts, separate from the current carrying contacts.

thermal characteristics

PARAMETER	MIN	TYP	MAX	UNIT
$R_{\theta JC}$ Junction to case thermal resistance			1	$^\circ\text{C/W}$

resistive-load-switching characteristics at 25°C case temperature

PARAMETER	TEST CONDITIONS †			MIN	TYP	MAX	UNIT
t_{on} Turn on time	$I_C = 10 \text{ A}$	$V_{CC} = 150 \text{ V}$	BUV48 (see Figures 1 and 2)			1.0	μs
t_s Storage time						3.0	μs
t_f Fall time				$I_{B(on)} = 2 \text{ A}$	$I_{B(off)} = -2 \text{ A}$		0.8
t_{on} Turn on time	$I_C = 8 \text{ A}$	$V_{CC} = 150 \text{ V}$	BUV48A (see Figures 1 and 2)			1.0	μs
t_s Storage time						3.0	μs
t_f Fall time				$I_{B(on)} = 1.6 \text{ A}$	$I_{B(off)} = -1.6 \text{ A}$		0.8

† Voltage and current values shown are nominal; exact values vary slightly with transistor parameters.

inductive-load-switching characteristics at 100°C case temperature

PARAMETER	TEST CONDITIONS †			MIN	TYP	MAX	UNIT
t_{sv} Voltage storage time	$I_C = 10 \text{ A}$	$I_{B(on)} = 2 \text{ A}$	BUV48 (see Figures 3 and 4)			4.0	μs
t_{fi} Current fall time				$V_{BE(off)} = -5 \text{ V}$		0.4	μs
t_{sv} Voltage storage time	$I_C = 8 \text{ A}$	$I_{B(on)} = 1.6 \text{ A}$	BUV48A (see Figures 3 and 4)			4.0	μs
t_{fi} Current fall time				$V_{BE(off)} = -5 \text{ V}$		0.4	μs

PRODUCT INFORMATION

PARAMETER MEASUREMENT INFORMATION

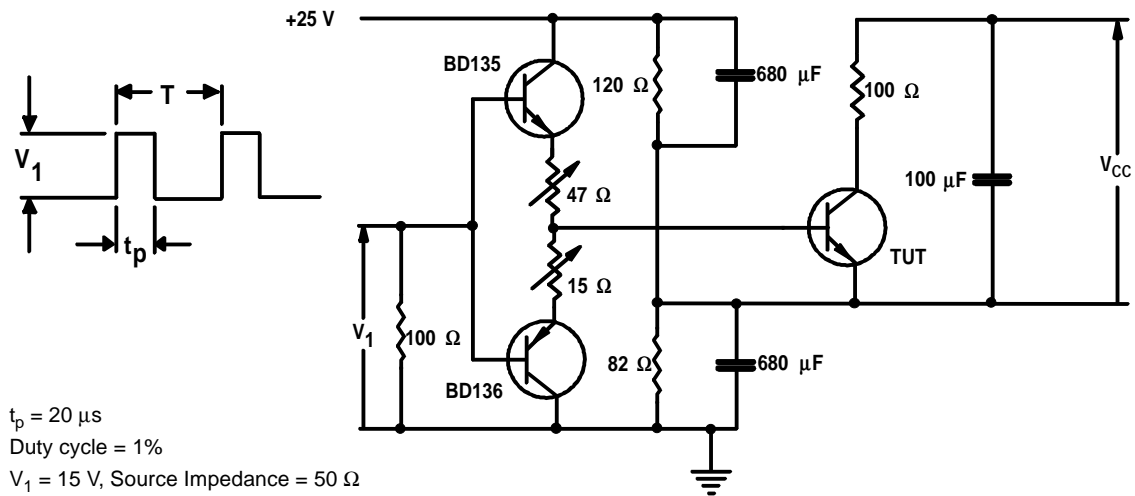

Figure 1. Resistive-Load Switching Test Circuit

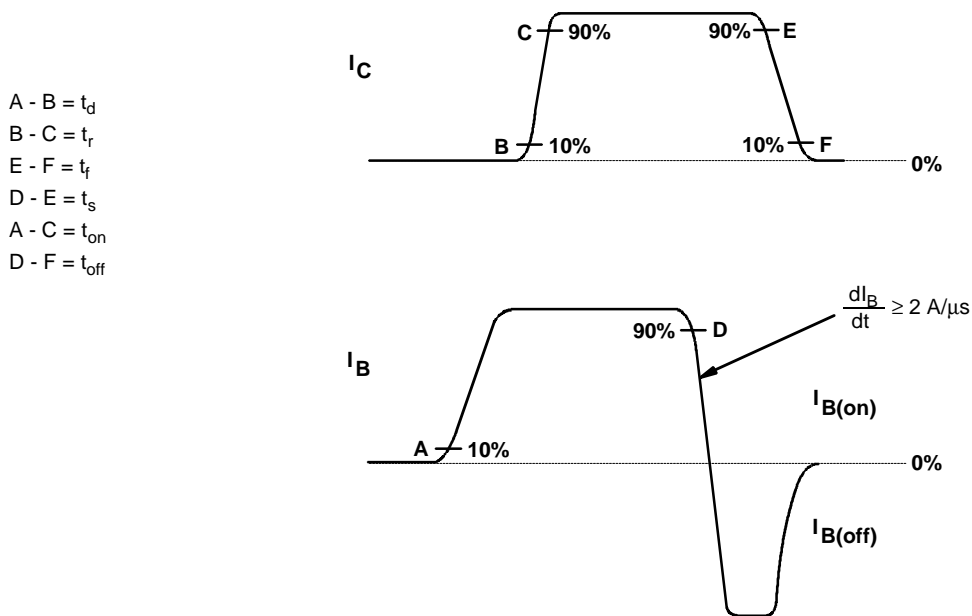

Figure 2. Resistive-Load Switching Waveforms

TYPICAL CHARACTERISTICS

TYPICAL DC CURRENT GAIN
VS
COLLECTOR CURRENT

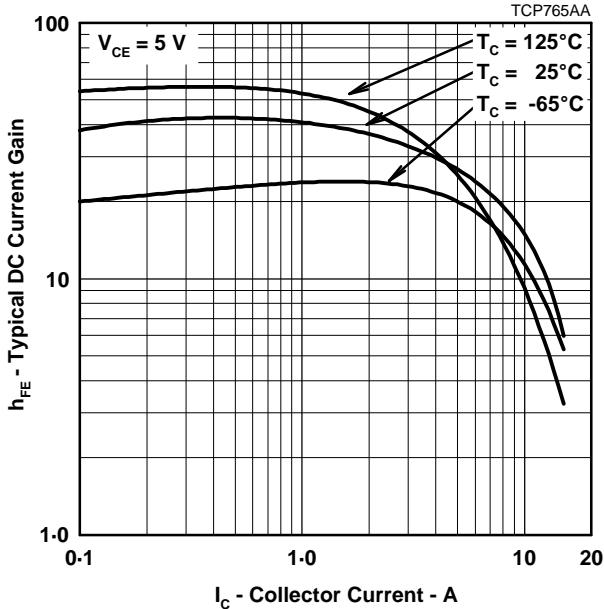

Figure 5.

COLLECTOR-EMITTER SATURATION VOLTAGE
VS
BASE CURRENT

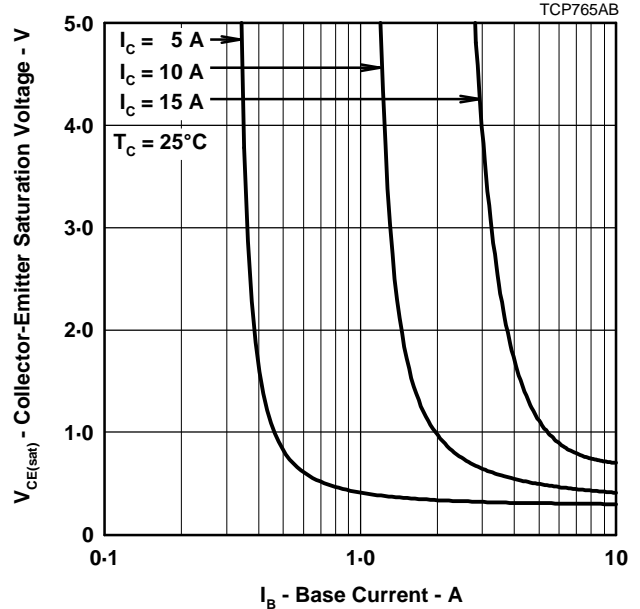

Figure 6.

COLLECTOR-EMITTER SATURATION VOLTAGE
VS
BASE CURRENT

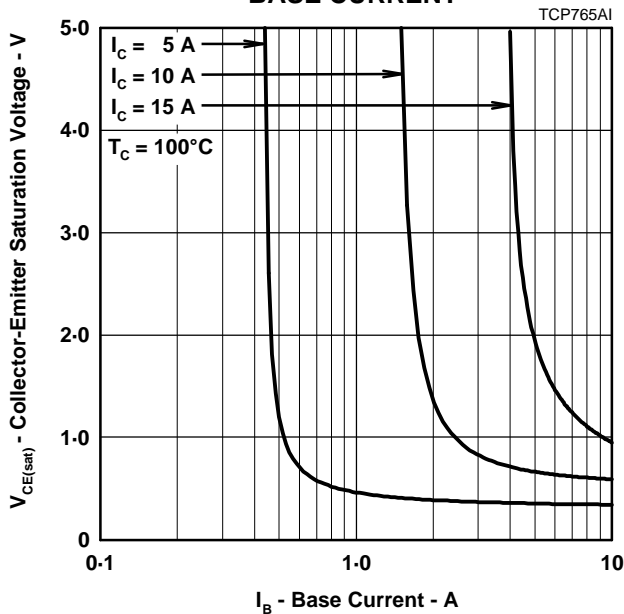

Figure 7.

BASE-EMITTER SATURATION VOLTAGE
VS
BASE CURRENT

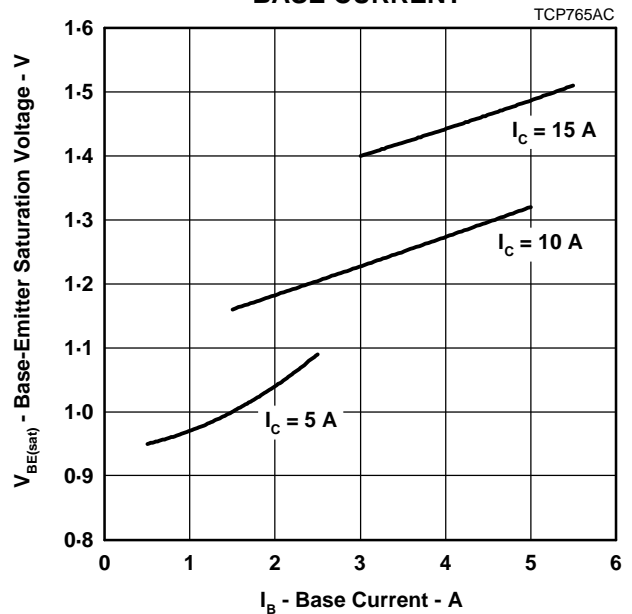

Figure 8.

BUV48, BUV48A NPN SILICON POWER TRANSISTORS

AUGUST 1978 - REVISED MARCH 1997

TYPICAL CHARACTERISTICS

COLLECTOR CUT-OFF CURRENT VS CASE TEMPERATURE

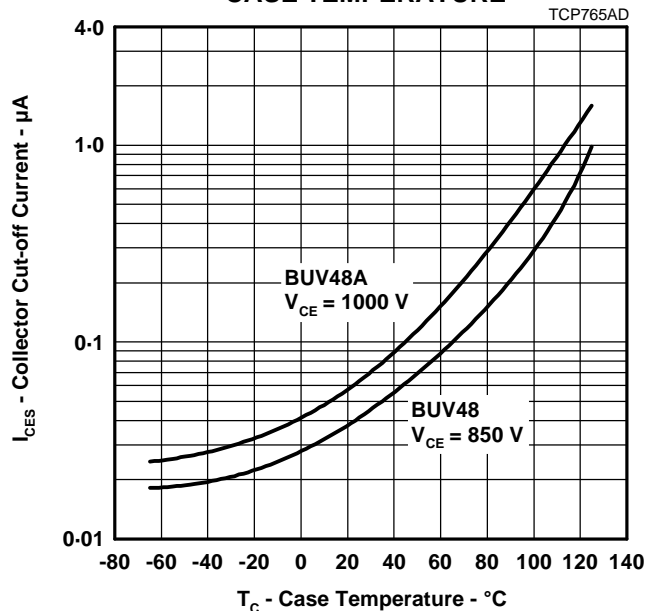

Figure 9.

MAXIMUM SAFE OPERATING REGIONS

MAXIMUM FORWARD-BIAS SAFE OPERATING AREA

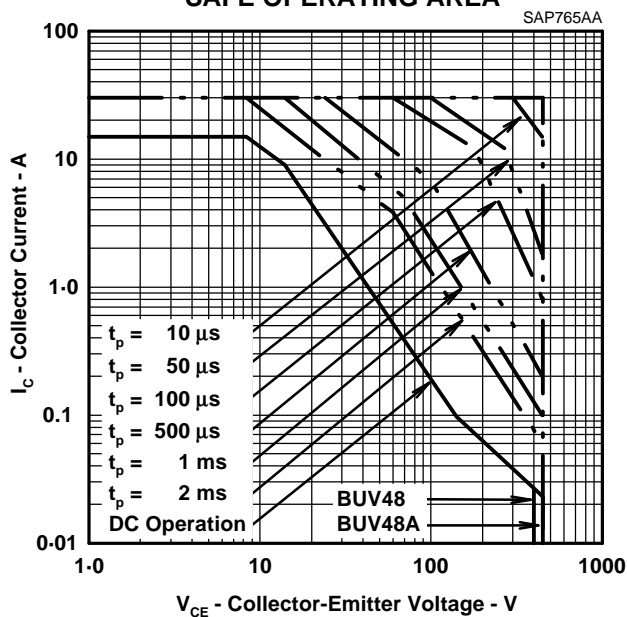

Figure 10.

BUV48, BUV48A

NPN SILICON POWER TRANSISTORS

AUGUST 1978 - REVISED MARCH 1997

IMPORTANT NOTICE

Power Innovations Limited (PI) reserves the right to make changes to its products or to discontinue any semiconductor product or service without notice, and advises its customers to verify, before placing orders, that the information being relied on is current.

PI warrants performance of its semiconductor products to the specifications applicable at the time of sale in accordance with PI's standard warranty. Testing and other quality control techniques are utilized to the extent PI deems necessary to support this warranty. Specific testing of all parameters of each device is not necessarily performed, except as mandated by government requirements.

PI accepts no liability for applications assistance, customer product design, software performance, or infringement of patents or services described herein. Nor is any license, either express or implied, granted under any patent right, copyright, design right, or other intellectual property right of PI covering or relating to any combination, machine, or process in which such semiconductor products or services might be or are used.

PI SEMICONDUCTOR PRODUCTS ARE NOT DESIGNED, INTENDED, AUTHORIZED, OR WARRANTED TO BE SUITABLE FOR USE IN LIFE-SUPPORT APPLICATIONS, DEVICES OR SYSTEMS.

Copyright © 1997, Power Innovations Limited



LittleDiode supplies new, hard to find or obsolete electronic components and semiconductors all over the world.

With over two million different components listed you are sure to find the part you need.

Feel free to visit us today at our online store:

LittleDiode.com

Looking forward to providing you with the best possible service.