

HIGH POWER NPN SILICON TRANSISTORS

- SGS-THOMSON PREFERRED SALESTYPES
- NPN TRANSISTOR
- HIGH CURRENT CAPABILITY
- FAST SWITCHING SPEED
- VERY LOW SATURATION VOLTAGE AND HIGH GAIN

APPLICATION

- SWITCHING REGULATORS
- MOTOR CONTROL
- HIGH FREQUENCY AND EFFICIENCY CONVERTERS

DESCRIPTION

The BUW48 and BUW49 are Multi-epitaxial planar NPN transistor in TO-218 plastic package.

It's intended for use in high frequency and efficiency converters such as motor controllers and industrial equipment.

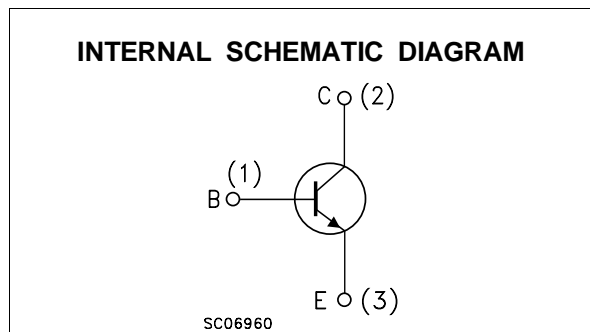
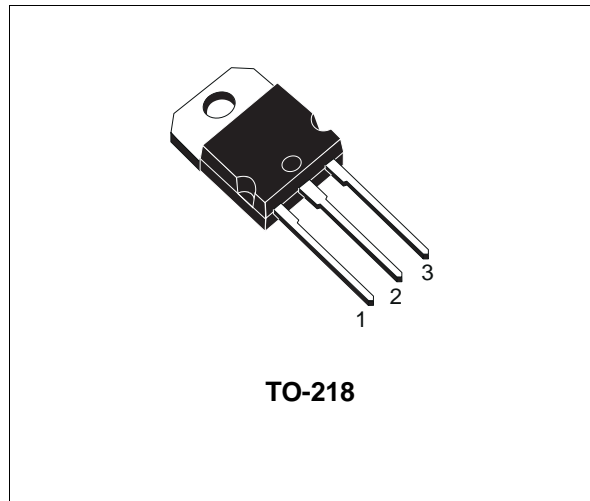

ABSOLUTE MAXIMUM RATINGS

Symbol	Parameter	Value		Unit
		BUW48	BUW49	Unit
V_{CEV}	Collector-emitter Voltage ($V_{BE} = -1.5V$)	120	160	V
V_{CEO}	Collector-emitter Voltage ($I_B = 0$)	60	80	V
V_{EBO}	Emitter-Base Voltage ($I_C = 0$)	7		V
I_C	Collector Current	30		A
I_{CM}	Collector Peak Current	45	40	A
I_B	Base Current	8	6	A
I_{BM}	Base Peak Current	12	10	A
P_{tot}	Total Power Dissipation at $T_{case} < 25\text{ }^\circ\text{C}$	150		W
T_{stg}	Storage Temperature	-65 to 175		$^\circ\text{C}$
T_j	Max Operating Junction Temperature	175		$^\circ\text{C}$

BUW48 / BUW49

THERMAL DATA

R _{thj-case}	Thermal Resistance Junction-case	Max	1	°C/W
-----------------------	----------------------------------	-----	---	------

ELECTRICAL CHARACTERISTICS (T_{case} = 25 °C unless otherwise specified)

Symbol	Parameter	Test Conditions	Min.	Typ.	Max.	Unit
I _{CEX}	Collector Cut-off Current	V _{CE} = V _{CES} V _{BE} = -1.5V V _{CE} = V _{CES} V _{BE} = -1.5V T _c = 125°C			1 3	mA mA
I _{EBO}	Emitter Cut-off Current (I _c = 0)	V _{EB} = 5 V			1	mA
V _{CEO(sus)*}	Collector-Emitter Sustaining Voltage	I _c = 0.2A L = 25 mH for BUW48 for BUW49	60 80			V V
V _{EB0}	Emitter-base Voltage (I _c = 0)	I _E = 50 mA	7			V
V _{CE(sat)*}	Collector-Emitter Saturation Voltage	I _c = 20A I _B = 2A for BUW48 I _c = 40A I _B = 4A for BUW49 I _c = 15A I _B = 1.5A for BUW48 I _c = 30A I _B = 3A for BUW49			0.6 1.4 0.5 1.2	V V V V
V _{BE(sat)*}	Base-Emitter Saturation Voltage	I _c = 40A I _B = 4A for BUW48 I _c = 30A I _B = 3A for BUW49			2.1 2	V V
f _T	Transition Frequency	I _c = 1A V _{CE} = 15V f = 15 MHz		8		MHz

RESISTIVE LOAD

Symbol	Parameter	Test Conditions	Min.	Typ.	Max.	Unit
t _{on} t _s t _f	Turn-on Time Storage Time Fall Time	for BUW48 V _{CC} = 60V I _c = 40A I _{B1} = -I _{B2} = 4A		1.2 0.6 0.17	1.5 1.1 0.25	μs μs μs
t _s t _f	Storage Time Fall Time	for BUW48 V _{CC} = 60V I _c = 40A I _{B1} = -I _{B2} = 4A			1.65 0.5	μs μs
t _{on} t _s t _f	Turn-on Time Storage Time Fall Time	for BUW49 V _{CC} = 80V I _c = 30A I _{B1} = -I _{B2} = 4A		0.8 0.6 0.15	1.2 1.1 0.25	μs μs μs
t _s t _f	Storage Time Fall Time	for BUW49 V _{CC} = 80V I _c = 30A I _{B1} = -I _{B2} = 4A			1.65 0.5	μs μs

* Pulsed: Pulse duration = 300 μs, duty cycle < 1.5 %

TO-218 (SOT-93) MECHANICAL DATA

DIM.	mm			inch		
	MIN.	TYP.	MAX.	MIN.	TYP.	MAX.
A	4.7		4.9	0.185		0.193
C	1.17		1.37	0.046		0.054
D		2.5			0.098	
E	0.5		0.78	0.019		0.030
F	1.1		1.3	0.043		0.051
G	10.8		11.1	0.425		0.437
H	14.7		15.2	0.578		0.598
L2	-		16.2	-		0.637
L3		18			0.708	
L5	3.95		4.15	0.155		0.163
L6		31			1.220	
R	-		12.2	-		0.480
Ø	4		4.1	0.157		0.161

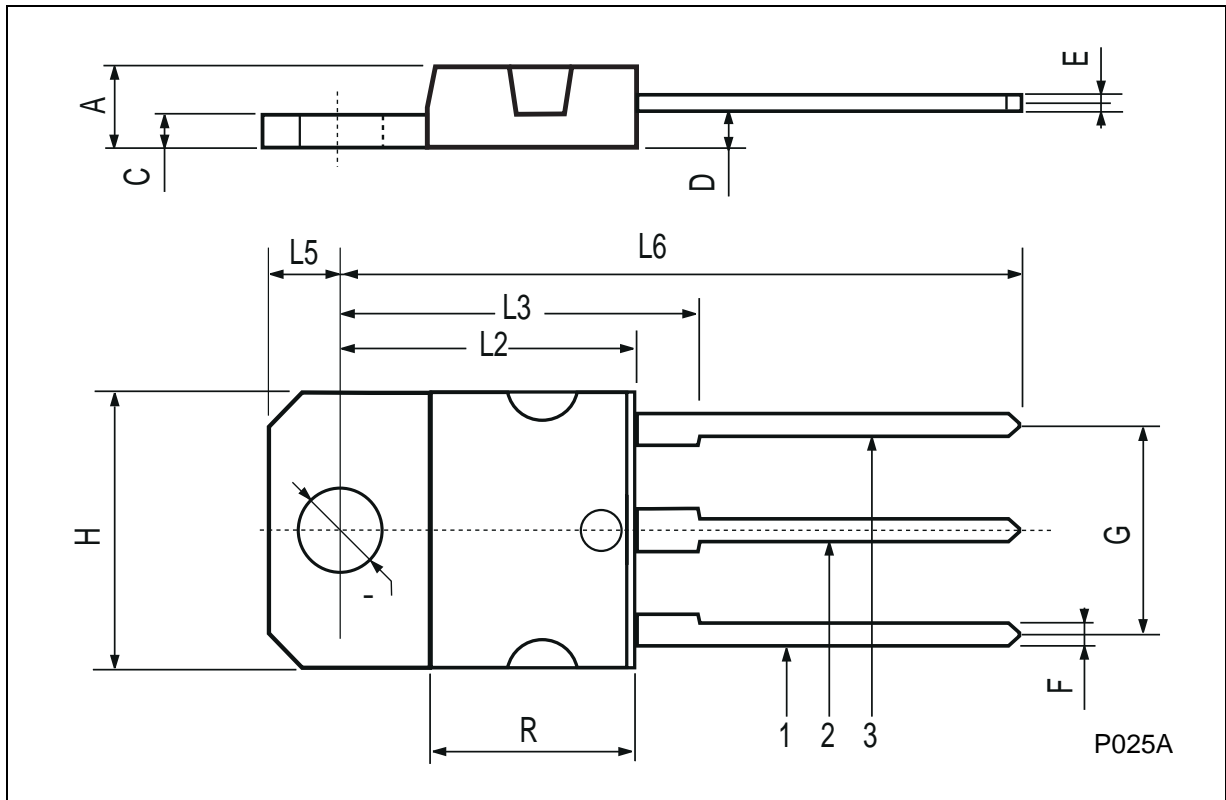

Information furnished is believed to be accurate and reliable. However, SGS-THOMSON Microelectronics assumes no responsibility for the consequences of use of such information nor for any infringement of patents or other rights of third parties which may result from its use. No license is granted by implication or otherwise under any patent or patent rights of SGS-THOMSON Microelectronics. Specifications mentioned in this publication are subject to change without notice. This publication supersedes and replaces all information previously supplied. SGS-THOMSON Microelectronics products are not authorized for use as critical components in life support devices or systems without express written approval of SGS-THOMSON Microelectronics.

© 1997 SGS-THOMSON Microelectronics - Printed in Italy - All Rights Reserved

SGS-THOMSON Microelectronics GROUP OF COMPANIES
Australia - Brazil - Canada - China - France - Germany - Hong Kong - Italy - Japan - Korea - Malaysia - Malta - Morocco - The Netherlands -
Singapore - Spain - Sweden - Switzerland - Taiwan - Thailand - United Kingdom - U.S.A
...



LittleDiode supplies new, hard to find or obsolete electronic components and semiconductors all over the world.

With over two million different components listed you are sure to find the part you need.

Feel free to visit us today at our online store:

LittleDiode.com

Looking forward to providing you with the best possible service.