

FSDH0165D

Fairchild Power Switch(FPS)

Features

- Single chip 650V 1A senseFET powerswitch
- Precision fixed operating frequency (100kHz)
- Internal start-up switch
- UVLO with hysteresis (6.7V/8.7V)
- Over load protection (typ. 4.5V)
- Over current protection (typ. 0.48A)
- Internal thermal shutdown function
- Secondary side regulation
- Auto-restart mode
- No load consumption < 250mW at 265VAC input

Applications

- Charger & adaptor for mobile phone, PDA & MP3
- Auxiliary power for PC

Description

The FSDH0165D is specially designed for an off-line SMPS with minimal external components. The FSDH0165D is a monolithic high voltage power switching regulator that combine the SenseFET(LDMOS) with voltage mode PWM control block. Included PWM controller features integrated fixed oscillator, under voltage lock out, leading edge blanking, optimized gate turn-on/turn-off driver, thermal shutdown protection and temperature compensated precision current sources for loop compensation and fault protection circuitry. compared to discrete MOSFET and controller or RCC switching converter solution, the FSDH0165D can reduce total component count, design size, weight and at the same time increase efficiency, productivity, and system reliability. It has a basic platform well suited for cost effective design in a flyback converter.

8-DIPH



1.Vstr 2.Vfb 3.4.5.6.GND 7.Vcc 8.Drain

Internal Block Diagram

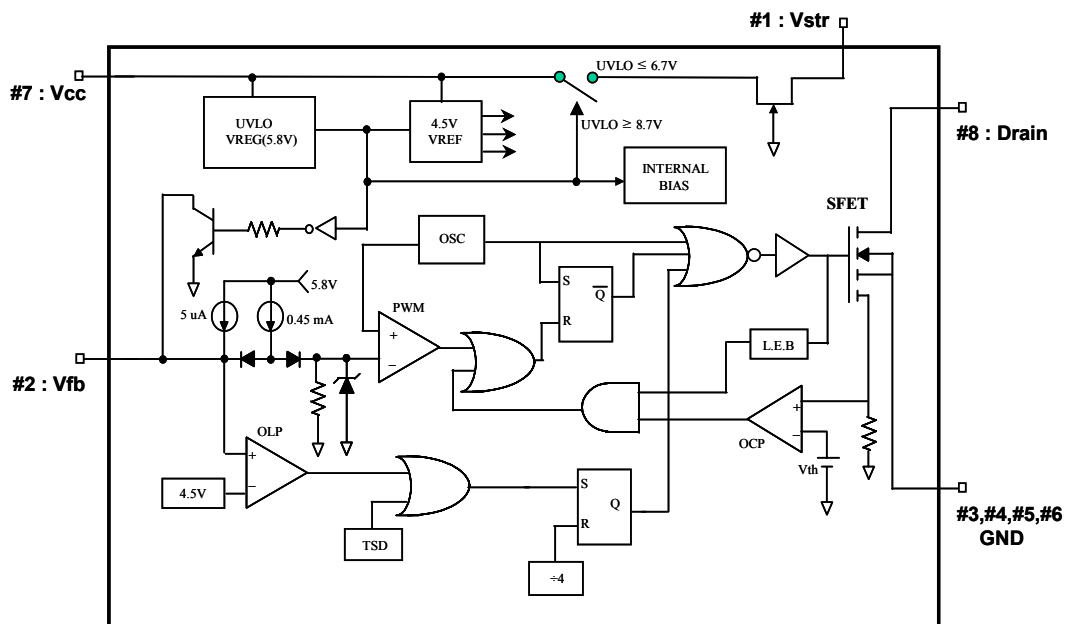

Rev.1.0.1

Absolute Maximum Ratings

(Ta=25°C unless otherwise specified)

Parameter	Symbol	Value	Unit
Continuous drain current (T _C =25°C)	I _D	0.6	ADC
Maximum supply voltage	V _{CC,MAX}	21	V
Input voltage range	V _{fb}	-0.3 to V _{start} (V _{CC})	V
Operating ambient temperature	T _A	-25 to +85	°C
Storage temperature range	T _{STG}	-55 to +150	°C

PIN Definitions

Pin Number	Pin Name	Pin Function Description
1	Vstr	This pin connects directly to the rectified AC line voltage source. At start up the internal switch supplies internal bias and charges an external capacitor that connects from the Vcc pin to ground. once this reaches 8.7V, Vstr is isolated internally.
2	Vfb	This pin is the inverting input of the PWM comparator, and it operates normally between 0.5V and 2.5V. It has a 0.45mA current source connected internally and a capacitor and opto coupler connected externally. A feedback voltage of 3.5V to 4.5V triggers overload protection (OLP). There is a time delay due to the 5uA current source, which prevents false triggering under transient conditions but still allows the protection mechanism to operate under true overload conditions.
3,4,5,6	GND	These pins are the control ground and the SenseFET Source.
7	Vcc	This is the positive supply voltage input. During start up, power is supplied to this input from Pin 1. When Vcc reaches the UVLO upper threshold (8.7V), the start up Internal Switch (Vstr) turns off and power is supplied from auxiliary transformer winding.
8	Drain	This pin is designed to directly drive the converter transformer and is capable of switching a maximum of 650V and 1A.

Electrical Characteristics

(Ta=25°C unless otherwise specified)

Parameter	Symbol	Condition	Min.	Typ.	Max.	Unit
SENSEFET SECTION						
Drain-source breakdown voltage	BVDSS	V _{GS} = 0V, I _D = 100μA	650	-	-	V
Zero gate voltage drain current	IDSS	V _{DS} = 520V	-	-	100	μA
Static drain-source on resistance	R _{DS(ON)}	I _D = 50mA T _j = 25°C	-	15.6	18	Ω
		I _D = 50mA T _j = 100°C	-	25.7	30	Ω
Rise time	T _R	V _{DS} = 325V, I _D = 300mA	-	100	-	nS
Fall time	T _F	V _{DS} = 325V, I _D = 50mA	-	50	-	nS
START UP SECTION						
VSTR supply voltage	V _{str}	-	17	-	-	V
UVLO SECTION						
Start threshold voltage	V _{start}	-	8.0	8.7	9.4	V
Stop threshold voltage	V _{stop}	After turn on	6.0	6.7	7.4	V
OSCILLATOR SECTION						
Initial accuracy	F _{OSC}	T _j = 25°C	90	100	110	kHz
Maximum duty cycle	D _{max}	V _{fb} = 3V	64	67	70	%
Minimum duty cycle	D _{min}	V _{fb} = 0V	-	0	0	%
FEEDBACK SECTION						
Feedback source current	I _{FB}	V _{fb} = 0V	0.40	0.45	0.50	mA
Shutdown feedback voltage	V _{SD}	-	4.0	4.5	5.0	V
CURRENT LIMIT(SELF-PROTECTION)SECTION						
Peak current limit	I _{OVER}	Peak inductor current	0.40	0.48	0.56	A
PROTECTION SECTION						
Thermal shutdown temperature (T _j) ⁽¹⁾	T _{SD}	-	125	145	-	°C
TOTAL DEVICE SECTION						
Operating supply current	I _{OPR}	V _{CC} = 21V (Max)	-	-	4	mA

Note:

1. These parameters, although guaranteed, are not 100% tested in production

Typical Performance Characteristics

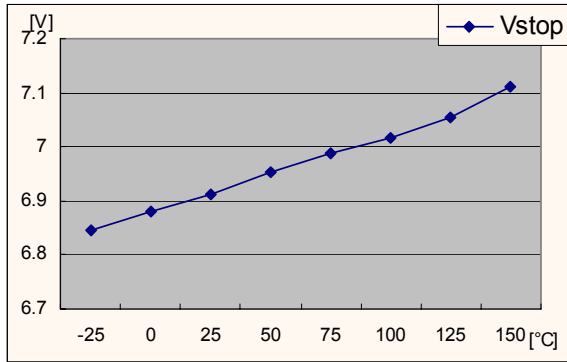

Figure 1. Stop Threshold Voltage

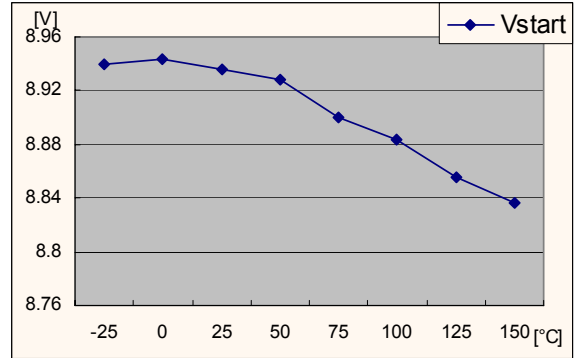

Figure 2. Start Threshold Voltage

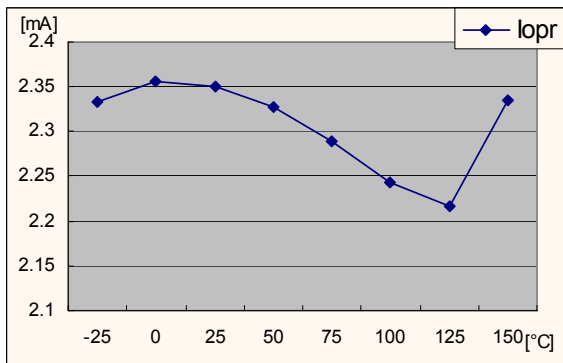

Figure 3. Operating Supply Current

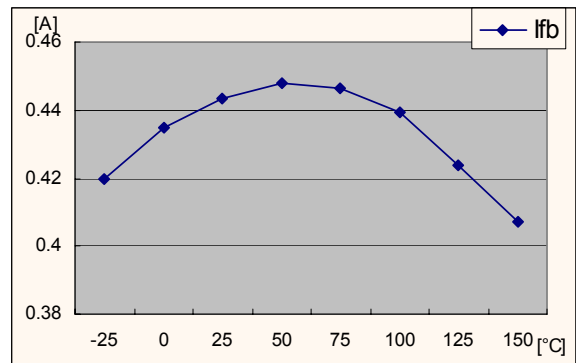

Figure 4. Feedback Source Current

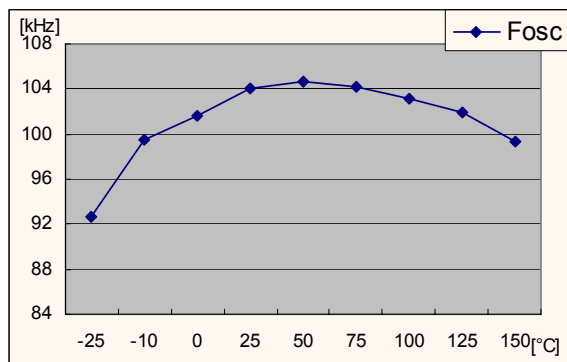

Figure 5. Initial Accuracy

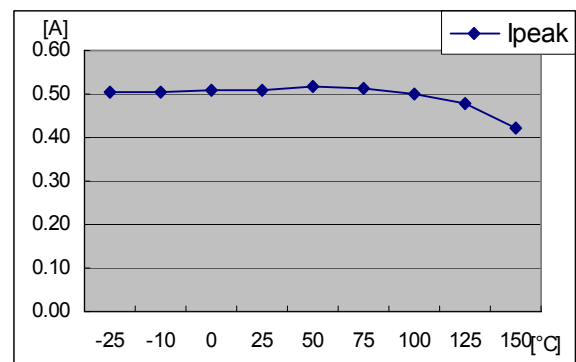

Figure 6. Peak Current Limit

Typical Performance Characteristics (Continued)

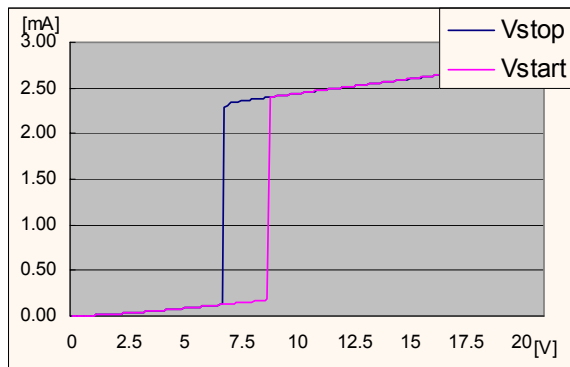

Figure 7. Stop/Start Threshold Voltage

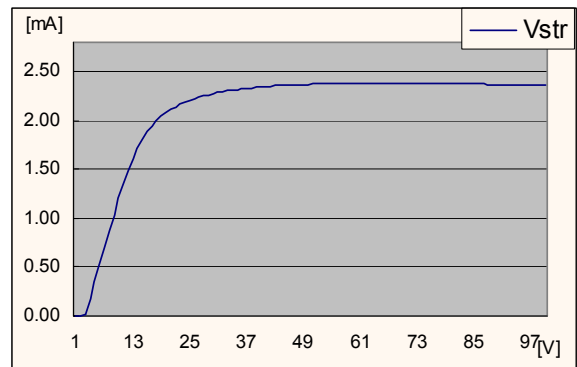

Figure 8. VSTR Supply Voltage

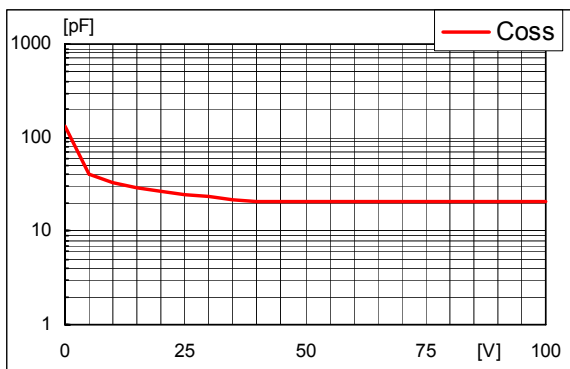

Figure 9. Coss vs. Drain Voltage

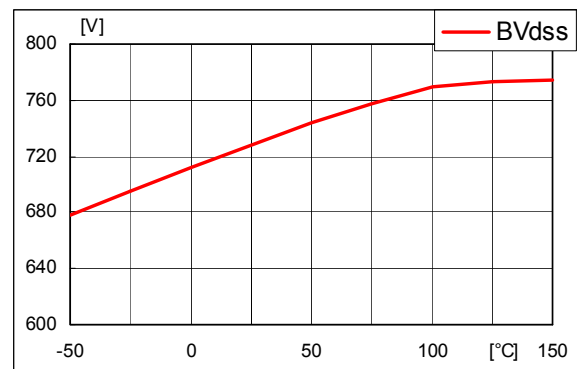
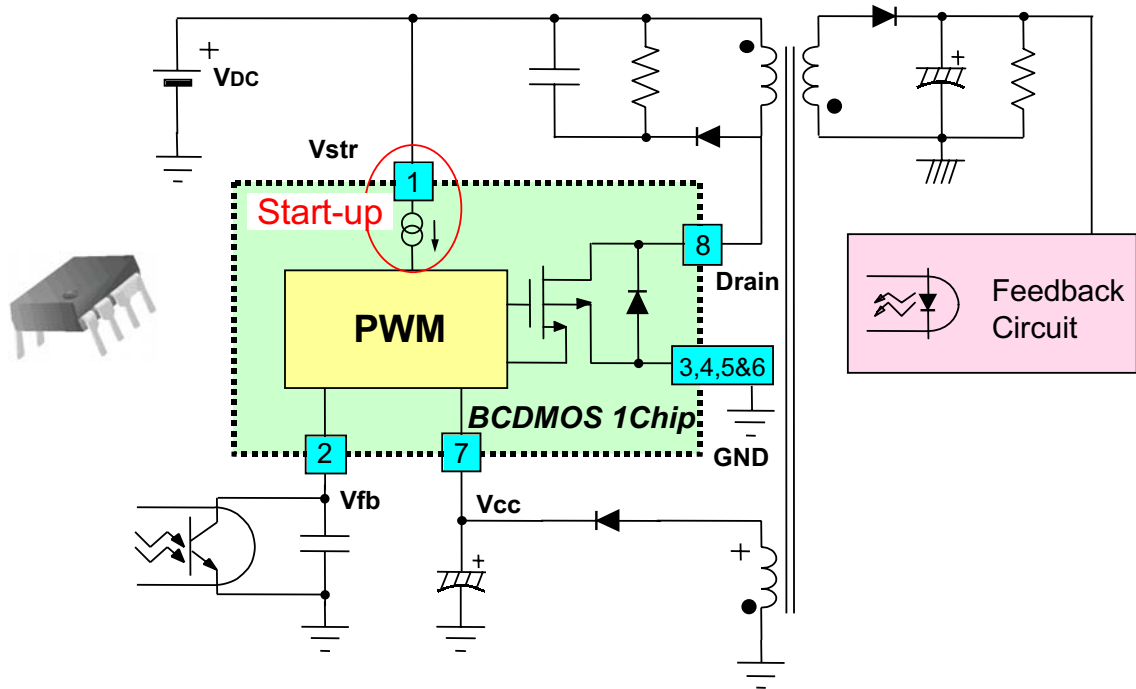

Figure 10. Breakdown vs. Temperature

Application Circuit



Package Dimensions

8-DIPH

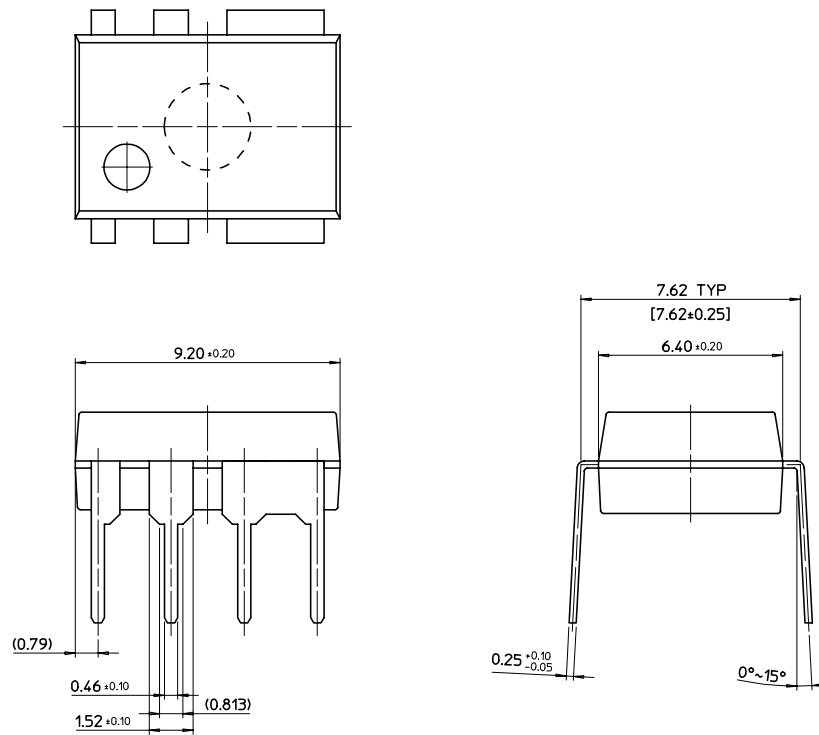

Ordering Information

Product Number	Package	Rating	Topr (°C)
FSDH0165D	8-DIPH	650V, 1A	-25°C to +85°C

DISCLAIMER

FAIRCHILD SEMICONDUCTOR RESERVES THE RIGHT TO MAKE CHANGES WITHOUT FURTHER NOTICE TO ANY PRODUCTS HEREIN TO IMPROVE RELIABILITY, FUNCTION OR DESIGN. FAIRCHILD DOES NOT ASSUME ANY LIABILITY ARISING OUT OF THE APPLICATION OR USE OF ANY PRODUCT OR CIRCUIT DESCRIBED HEREIN; NEITHER DOES IT CONVEY ANY LICENSE UNDER ITS PATENT RIGHTS, NOR THE RIGHTS OF OTHERS.

LIFE SUPPORT POLICY

FAIRCHILD'S PRODUCTS ARE NOT AUTHORIZED FOR USE AS CRITICAL COMPONENTS IN LIFE SUPPORT DEVICES OR SYSTEMS WITHOUT THE EXPRESS WRITTEN APPROVAL OF THE PRESIDENT OF FAIRCHILD SEMICONDUCTOR CORPORATION. As used herein:

1. Life support devices or systems are devices or systems which, (a) are intended for surgical implant into the body, or (b) support or sustain life, and (c) whose failure to perform when properly used in accordance with instructions for use provided in the labeling, can be reasonably expected to result in a significant injury of the user.
2. A critical component in any component of a life support device or system whose failure to perform can be reasonably expected to cause the failure of the life support device or system, or to affect its safety or effectiveness.



LittleDiode supplies new, hard to find or obsolete electronic components and semiconductors all over the world.

With over two million different components listed you are sure to find the part you need.

Feel free to visit us today at our online store:

LittleDiode.com

Looking forward to providing you with the best possible service.