

# DATA SHEET

Part No.	AN17820B
Package Code No.	HSIP012-P-0000L

Maintenance/Discontinued includes following lifecycle stage.  
planned maintenance type  
maintenance type  
planned discontinued type  
discontinued type  
Please visit following URL about latest information.  
<http://www.semicon.panasonic.co.jp/en/>

## Contents

■ Overview .....	3
■ Features .....	3
■ Applications .....	3
■ Package .....	3
■ Type .....	3
■ Application Circuit Example .....	4
■ Block Diagram .....	4
■ Pin Descriptions .....	5
■ Absolute Maximum Ratings .....	6
■ Operating Supply Voltage Range .....	6
■ Electrical Characteristics .....	7
■ Electrical Characteristics (Reference values for design) .....	7
■ Technical Data .....	8
• I/O block circuit diagrams and pin function descriptions .....	8
• Application information .....	10
• $P_D - T_a$ diagram .....	13
■ Usage Notes .....	14

# AN17820B

Dual channel BTL 7.5 W audio power amplifier with volume and standby control

## ■ Overview

AN17820B is a monolithic integrated circuit designed for 7.5 W × 2-ch (8 Ω) output audio power amplifier. It is a dual channel BTL IC suitable for stereo operation in TV application.

## ■ Features

- Built-in stand-by circuit
- Built-in volume circuit

## ■ Applications

- ICs for low frequency amplifier

## ■ Package

- 12 pin plastic single inline package with heat sink (SIP type)

## ■ Type

- Silicon monolithic bipolar IC

■ Application Circuit Example

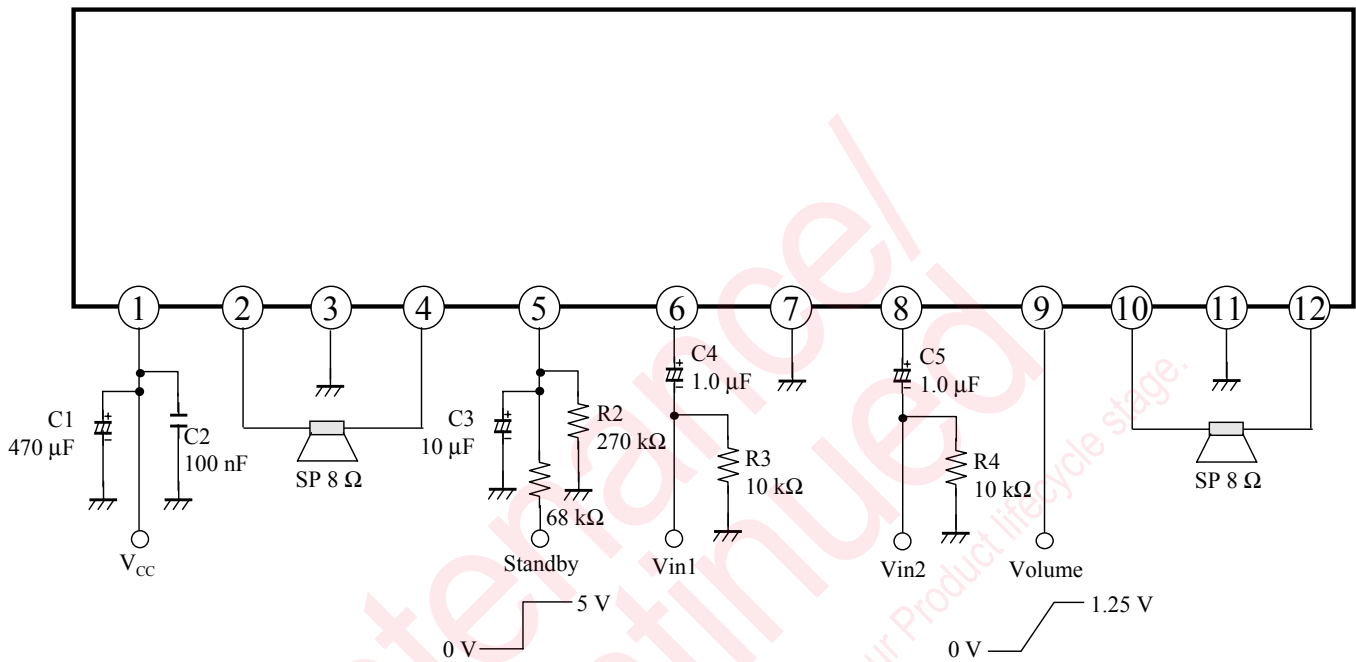

Standby pin	IC
0 V	Off
5 V	On

Note) This application circuit is shown as an example but does not guarantee the design for mass production set.

■ Block Diagram

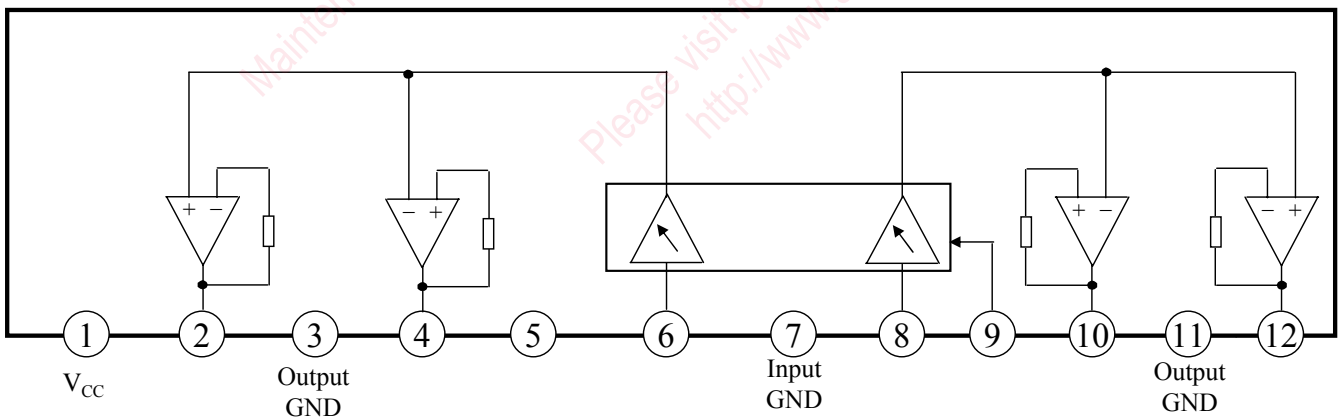

Note) This block diagram is for explaining functions. The part of the block diagram may be omitted, or it may be simplified.

### ■ Pin Descriptions

Pin No.	Pin name	Type	Description
1	V <sub>CC</sub>	Power supply	V <sub>CC</sub>
2	OUT1(+)	Output	Channel 1 positive phase output
3	GND(OUT1)	Ground	GND for channel 1 output
4	OUT1(-)	Output	Channel 1 negative phase output
5	Standby	Input	Standby
6	IN1	Input	Channel 1 input
7	GND (Input)	Ground	Input GND
8	IN2	Input	Channel 2 input
9	Volume	Input	Volume
10	OUT2(-)	Output	Channel 2 negative phase output
11	GND(OUT2)	Ground	GND for channel 2 output
12	OUT2(+)	Output	Channel 2 positive phase output

### ■ Absolute Maximum Ratings

A No.	Parameter	Symbol	Rating	Unit	Note
1	Supply voltage	$V_{CC}$	24.0	V	*1, *2
2	Supply current	$I_{CC}$	4.0	A	—
3	Power dissipation	$P_D$	1 904	mW	*3
4	Operating ambient temperature	$T_{opr}$	-25 to +70	°C	*4
5	Storage temperature	$T_{stg}$	-55 to +150	°C	*4

Note) \*1: The range under absolute maximum ratings, power dissipation.

\*2: No signal input.

\*3: Power dissipation shows the value of only package at  $T_a = 70^\circ\text{C}$ .

When using this IC, refer to the  $\bullet P_D - T_a$  diagram in the ■ Technical Data and use under the condition not exceeding the allowable value.

\*4: Expect for the storage temperature and operating ambient temperature, all ratings are for  $T_a = 25^\circ\text{C}$ .

### ■ Operating Supply Voltage Range

Parameter	Symbol	Range	Unit	Note
Supply voltage range	$V_{CC}$	5.0 to 18.0	V	—

Note) The values under the condition not exceeding the above absolute maximum ratings and the power dissipation.

### ■ Electrical Characteristics at $V_{CC} = 12.0\text{ V}$

Note) Unless otherwise specified,  $T_a = 25^\circ\text{C} \pm 2^\circ\text{C}$ , Frequency = 1 kHz,  $R_L = 8\ \Omega$ .

B No.	Parameter	Symbol	Conditions	Limits			Unit	Note
				Min	Typ	Max		
1	Quiescent circuit current	$I_{CQ}$	$V_{in} = 0\text{ V}$ , $V_{ol} = 0\text{ V}$	—	45	100	mA	—
2	Standby current	$I_{STB}$	$V_{in} = 0\text{ V}$ , $V_{ol} = 0\text{ V}$	—	1	10	$\mu\text{A}$	—
3	Output noise voltage	$V_{NO}$	$V_{ol} = 0\text{ V}$ , $R_g = 10\text{ k}\Omega$	—	0.25	0.6	mV[rms]	*
4	Voltage gain	$G_V$	$P_O = 1.0\text{ W}$ , $V_{ol} = 1.25\text{ V}$	38	40	42	dB	—
5	Total harmonic distortion	THD	$P_O = 1.0\text{ W}$ , $V_{ol} = 1.25\text{ V}$	—	0.15	0.5	%	—
6	Maximum power output 1	$P_{O1}$	THD = 10%, $V_{ol} = 1.25\text{ V}$	6.0	7.5	—	W	—
7	Maximum power output 2	$P_{O2}$	$V_{CC} = 15\text{ V}$ , THD = 10%, $V_{ol} = 1.25\text{ V}$	10.0	12.5	—	W	—
8	Ripple rejection ratio	RR	$R_g = 10\text{ k}\Omega$ , $V_{ol} = 0\text{ V}$ , $V_r = 1\text{ V[rms]}$ , $f_r = 120\text{ Hz}$	30	50	—	dB	*
9	Output offset voltage	$V_{OFF}$	$V_{ol} = 0\text{ V}$ , $R_g = 10\text{ k}\Omega$	-350	0	350	mV	—
10	Volume attenuation ratio	Att	$P_O = 1.0\text{ W}$ , $V_{ol} = 0\text{ V}$	70	80	—	dB	*
11	Channel balance 1	CB1	$P_O = 1.0\text{ W}$ , $V_{ol} = 1.25\text{ V}$	-1	0	1	dB	—
12	Channel balance 2	CB2	$P_O = 1.0\text{ W}$ , $V_{ol} = 0.6\text{ V}$	-2	0	2	dB	—
13	Middle voltage gain	$G_{Vm}$	$P_O = 1.0\text{ W}$ , $V_{ol} = 0.6\text{ V}$	26.5	29.5	32.5	dB	—
14	Channel crosstalk	CT	$P_O = 1.0\text{ W}$ , $V_{ol} = 1.25\text{ V}$	40	55	—	dB	—

Note) \*: For this measurement, use the BPF = 15 Hz to 30 kHz (12 dB/OCT).

### ■ Electrical Characteristics (Reference values for design) at $V_{CC} = 12.0\text{ V}$

Note) Unless otherwise specified,  $T_a = 25^\circ\text{C} \pm 2^\circ\text{C}$ , Frequency = 1 kHz,  $R_L = 8\ \Omega$ .

The characteristics listed below are reference values for design of the IC and are not guaranteed by inspection.

If a problem does occur related to these characteristics, Panasonic will respond in good faith to user concerns.

B No.	Parameter	Symbol	Conditions	Limits			Unit	Note
				Min	Typ	Max		
15	Standby pin current	$I_{STB2}$	$V_{in} = 0\text{ V}$ , $V_{STB} = 3.0\text{ V}$	—	—	25	$\mu\text{A}$	—
16	Volume pin current	$I_{VOL}$	$V_{in} = 0\text{ V}$ , $V_{ol} = 0\text{ V}$	-12	—	—	$\mu\text{A}$	—
17	Input impedance	$Z_i$	$V_{in} = \pm 0.3\text{ V}_{DC}$	24	30	36	k $\Omega$	—

■ Technical Data

- I/O block circuit diagrams and pin function descriptions

Note) The characteristics listed below are reference values based on the IC design and are not guaranteed.

Pin No.	DC bias	Internal circuit	Description
1	12 V typ.	—	Power supply pin.
2	$V_{CC}/2$		Channel 1 positive output pin
3	0 V	—	Ground for channel 1 output
4	$V_{CC}/2$		Channel 1 negative output pin
5	5 V typ.		Standby control pin Standby "ON" = 0 V Standby "OFF" = 5 V
6	1.45 V		Channel 1 input pin.

### ■ Technical Data (continued)

#### • I/O block circuit diagrams and pin function descriptions (continued)

Note) The characteristics listed below are reference values based on the IC design and are not guaranteed.

Pin No.	DC bias	Internal circuit	Description
7	0 V	—	Input ground
8	1.45 V		Channel 2 input pin
9	—		Volume control pin Volume "OFF" = 0V Max. Volume = 1.25 V
10	$V_{CC}/2$		Channel 2 negative output pin
11	0 V	—	Ground for channel 2 output
12	$V_{CC}/2$		Channel 2 positive output pin

## ■ Technical Data (continued)

### • Application information

#### 1. Supply decoupling

To ensure a stable supply and achieve better ripple rejection, decoupling capacitors need to be connected to  $V_{CC}$  (Pin 1).

Decoupling capacitors should have small equivalent series resistance (ESR). This is to prevent resistive losses and introduction of undesirable phase shift to internal circuit.

A ceramic capacitor of 100 nF in parallel with a non-ceramic (tantalum or aluminum electrolytic) capacitor of 470  $\mu$ F are suggested. This combination has a small ESR over a wide frequency range.

Although small in size and ESR, large valued ceramic capacitor is not advisable to use. Current surges during power On/Off might store energy in the inductances of the power leads, and a large voltage spike could be created when the stored energy is transferred from the inductances to the ceramic capacitor. The amplitude of the spike could exceed twice the supply voltage.

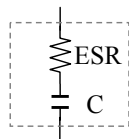

Fig. 1. Practical capacitor

#### 2. Standby operation

Standby pin should be connected with carefully selected components in order to avoid "pop noise" during Standby On/Off transient.

The 68 k $\Omega$  resistor and 10  $\mu$ F capacitor pair can delay the rising of voltage at pin 5 to reach the Standby threshold. When standby is switching on together with supply, this delay would be very useful to ensure no "pop noise".

If the standby voltage is provided by a microcontroller, the suppression of "Pop" could even be better.

The microcontroller can set a delay of 100 ms to 200 ms between the supply and Standby On/Off.

The 68 k $\Omega$  and 270 k $\Omega$  resistor also form a voltage divider, which determines the Standby threshold.

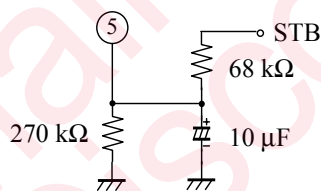

Fig. 2. Standby circuit

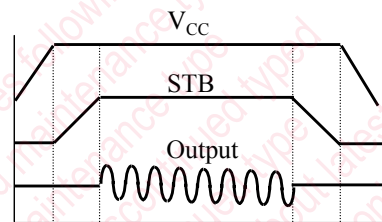

Fig. 3. Standby On/Off logic

#### 3. Input DC decoupling

Before the input signal reaches differential amplifier stage, its DC component should be removed.

The capacitor of 1  $\mu$ F pass only AC signal and the 10 k $\Omega$  resistor forms a DC path to ground.

The 1 nF capacitor in parallel to the 10 k $\Omega$  resistor is optional and it serves to filter out high frequency noise at the input.

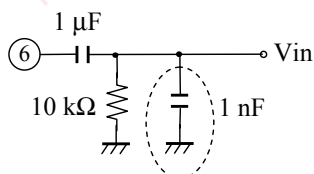

Fig. 4. Input DC decoupling

## ■ Technical Data (continued)

### • Application information (continued)

#### 4. Output zobel network

It should be noted that this device is designed such that the zobel network (RC pair) at the output pins is not necessary for stable operation.

In practical application, the zobel network may be applied optionally for two reasons:

- Ensuring stability for different PCB layout and speaker types.
- Ability to withstand to high ESD

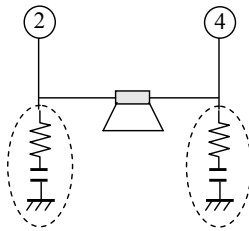

Fig. 5. Output zobel network

#### 5. Good PCB layout can improve chip's performances.

To reduce stray capacitances at the inputs and outputs, external components are to be placed as close to the pins as possible.

PCB traces conducting huge current, such as those connected to supply or outputs, should be kept short and wide. This will keep inductances low and resistive loss to a minimum.

The layout of test board is as shown below.

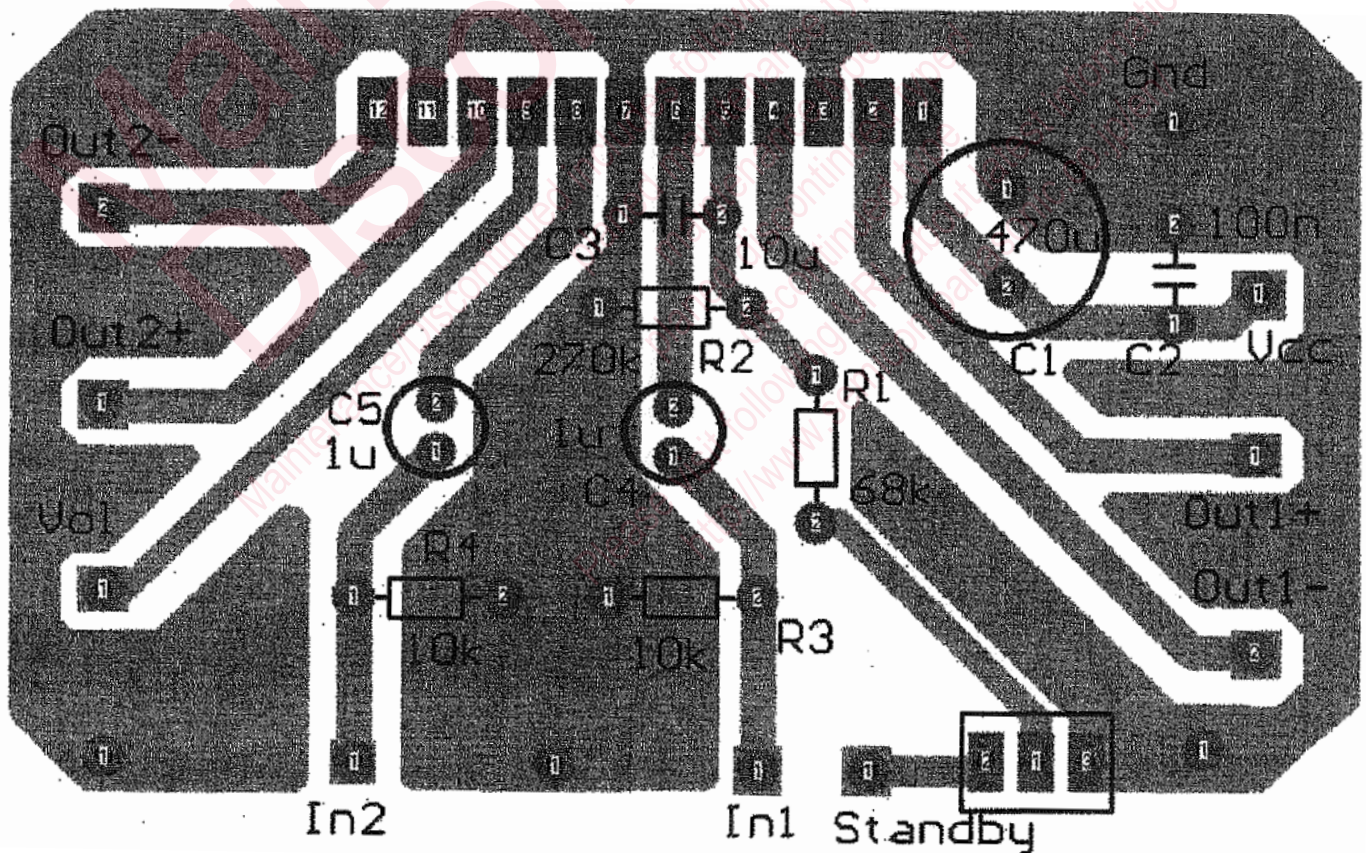

## ■ Technical Data (continued)

## • Application information (continued)

## 6. Output power (W) — Supply voltage (V)

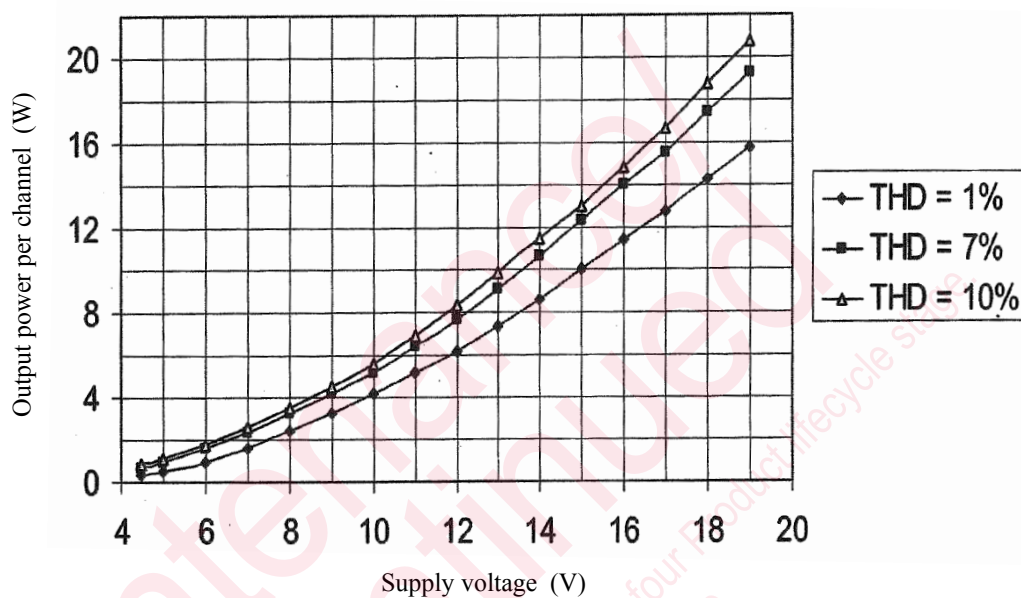

Conditions: Frequency = 1 kHz,  $R_L = 8 \Omega$

## ■ Technical Data (continued)

- $P_D$  —  $T_a$  diagram

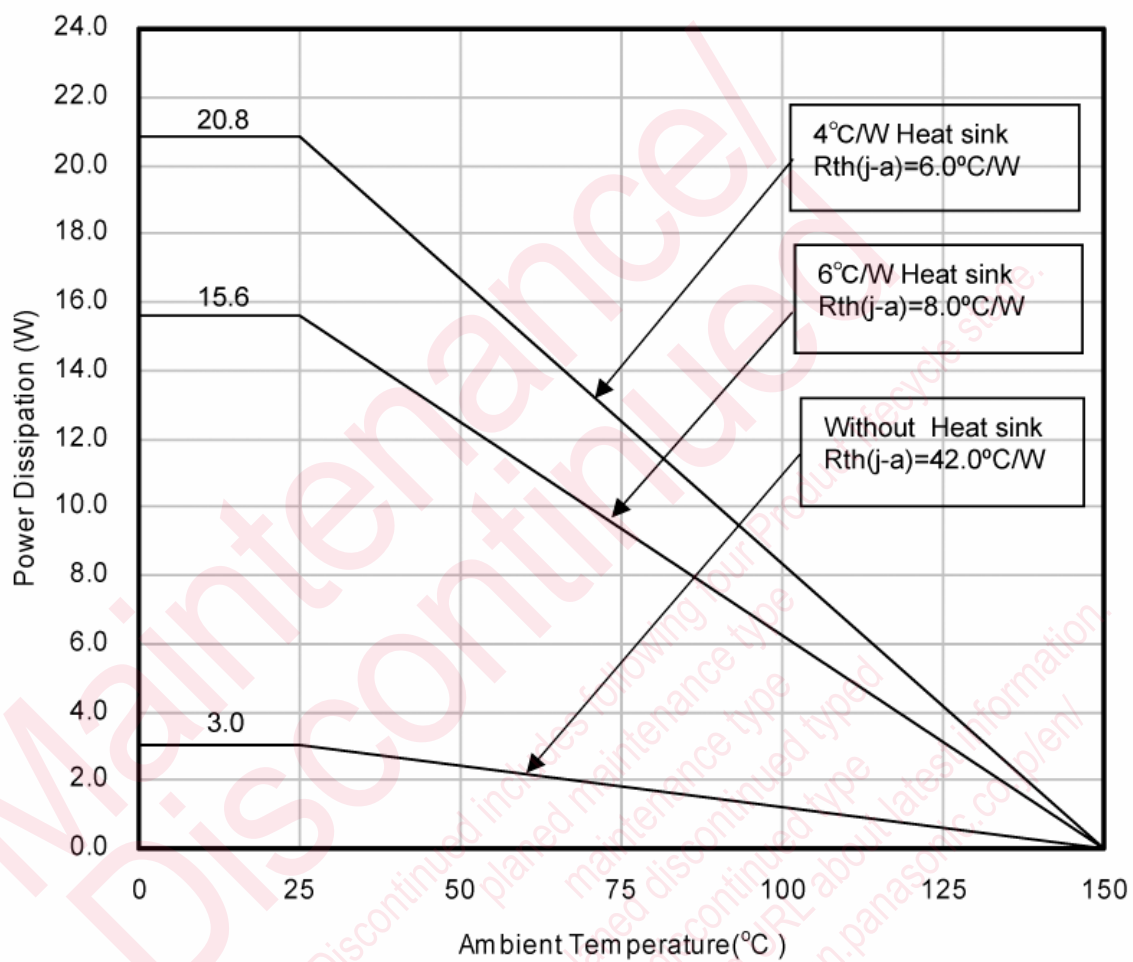

$$R_{th(j-c)}=2.0^{\circ}\text{C/W}$$

**■ Usage Notes**

1. This IC is intended to be used for general electronic equipment.  
Consult our sales staff in advance for information on the following applications:
  - Special applications in which exceptional quality and reliability are required, or if the failure or malfunction of this IC may directly jeopardize life or harm the human body.
  - Any applications other than the standard applications intended.
    - (1) Space appliance (such as artificial satellite, and rocket)
    - (2) Traffic control equipment (such as for automobile, airplane, train, and ship)
    - (3) Medical equipment for life support
    - (4) Submarine transponder
    - (5) Control equipment for power plant
    - (6) Disaster prevention and security device
    - (7) Weapon
    - (8) Others: Applications of which reliability equivalent to (1) to (7) is required
2. Pay attention to the direction of LSI. When mounting it in the wrong direction onto the PCB (printed-circuit-board), it might smoke or ignite.
3. Pay attention in the PCB (printed-circuit-board) pattern layout in order to prevent damage due to short circuit between pins. In addition, refer to the **■ Pin Description** for the pin configuration.
4. Perform a visual inspection on the PCB before applying power, otherwise damage might happen due to problems such as a solder-bridge between the pins of the semiconductor device. Also, perform a full technical verification on the assembly quality, because the same damage possibly can happen due to conductive substances, such as solder ball, that adhere to the LSI during transportation.
5. Take notice in the use of this product that it might break or occasionally smoke when an abnormal state occurs such as output pin –  $V_{CC}$  short (power supply fault), output pin – GND short (ground fault), output-to-output-pin short (load short), or pin shift and, safety measures such as an installation of fuses are recommended because the extent of the above-mentioned damage and smoke emission will depend on the current capability of the power supply.
6. When designing your equipment, comply with the range of absolute maximum rating and the guaranteed operating conditions (operating power supply voltage and operating environment etc.). Especially, please be careful not to exceed the range of absolute maximum rating on the transient state, such as power-on, power-off and mode-switching. Otherwise, we will not be liable for any defect which may arise later in your equipment.  
Even when the products are used within the guaranteed values, take into the consideration of incidence of break down and failure mode, possible to occur to semiconductor products. Measures on the systems such as redundant design, arresting the spread of fire or preventing glitch are recommended in order to prevent physical injury, fire, social damages, for example, by using the products.
7. When using the LSI for new models, verify the safety including the long-term reliability for each product.
8. When the application system is designed by using this LSI, be sure to confirm notes in this book.  
Be sure to read the notes to descriptions and the usage notes in the book.
9. Ground the radiation fin so that there will be no difference in electric potential between the radiation fin and ground.
10. The thermal protection circuit operates at a  $T_j$  of approximately 150°C. The thermal protection circuit is reset automatically when the temperature drops.
11. Make sure that the heat radiation design is effective enough if the  $V_{CC}$  is comparatively high or the IC operates at high output power.
12. Connect only ground pin for signal sources to the signal GND pin of the amplifier on the previous stage.
13. For installation to heat-sink, grease for heat-sink should be applied to reduce the contact heat resistance and increase the radiating effect. Ensure that there is no foreign objects between IC and heat-sink which may cause cracks and additional stress to the IC.

## ■ Usage Notes (continued)

14. The IC should be mounted onto a flat-surfaced heat-sink first, in a manner where little stress is applied, then solder the leads on the IC to the board.
15. If the tightening torque of the heat-sink is too low, the heat resistance will become large. If it is too high, the physical device will be distorted which might result in a failure. The tightening torque recommended is 78.5N.cm.
16. Fasten the heat-sink firmly on the chassis or board. Do not create a structure where the heat-sink is supported by the IC.
17. The protection circuit is for maintaining safety against an abnormal operation. Therefore, design the protection circuit such that it should not operate during normal operation. Especially for the over-temperature protection circuit, if the area of safe operation or the absolute maximum rating is momentarily exceeded by output pin to  $V_{CC}$  short, or output pin to GND short (ground fault), the LSI might be damaged before the over-temperature protection circuit starts working.
18. Unless specified in the product specifications, make sure that negative voltage or excessive voltage are not applied to the pins because the device might be damaged, which could happen due to negative voltage or excessive voltage generated during the ON and OFF timing when the inductive load of a motor coil or actuator coils of optical pick-up is being driven.
19. Check the risk that is caused by the failure of external components.
20. In the event of abnormal operation condition whereby the output terminals swing towards supply / ground, the destruction of the speaker may result. As such, please ensure that the rating of the speaker is appropriate and made of non-flammable material.
21. In the event of abnormal condition whereby the output terminals are short-circuit to ground or  $V_{CC}$  terminal, very high heat dissipation may occur resulting in heat transfer directly or indirectly to peripheral components. Please consider non-flammable materials for the peripheral components or setup including the PCB.

## Request for your special attention and precautions in using the technical information and semiconductors described in this book

- (1) If any of the products or technical information described in this book is to be exported or provided to non-residents, the laws and regulations of the exporting country, especially, those with regard to security export control, must be observed.
- (2) The technical information described in this book is intended only to show the main characteristics and application circuit examples of the products. No license is granted in and to any intellectual property right or other right owned by Panasonic Corporation or any other company. Therefore, no responsibility is assumed by our company as to the infringement upon any such right owned by any other company which may arise as a result of the use of technical information described in this book.
- (3) The products described in this book are intended to be used for standard applications or general electronic equipment (such as office equipment, communications equipment, measuring instruments and household appliances).  
Consult our sales staff in advance for information on the following applications:
  - Special applications (such as for airplanes, aerospace, automobiles, traffic control equipment, combustion equipment, life support systems and safety devices) in which exceptional quality and reliability are required, or if the failure or malfunction of the products may directly jeopardize life or harm the human body.
  - Any applications other than the standard applications intended.
- (4) The products and product specifications described in this book are subject to change without notice for modification and/or improvement. At the final stage of your design, purchasing, or use of the products, therefore, ask for the most up-to-date Product Standards in advance to make sure that the latest specifications satisfy your requirements.
- (5) When designing your equipment, comply with the range of absolute maximum rating and the guaranteed operating conditions (operating power supply voltage and operating environment etc.). Especially, please be careful not to exceed the range of absolute maximum rating on the transient state, such as power-on, power-off and mode-switching. Otherwise, we will not be liable for any defect which may arise later in your equipment.
  - Even when the products are used within the guaranteed values, take into the consideration of incidence of break down and failure mode, possible to occur to semiconductor products. Measures on the systems such as redundant design, arresting the spread of fire or preventing glitch are recommended in order to prevent physical injury, fire, social damages, for example, by using the products.
- (6) Comply with the instructions for use in order to prevent breakdown and characteristics change due to external factors (ESD, EOS, thermal stress and mechanical stress) at the time of handling, mounting or at customer's process. When using products for which damp-proof packing is required, satisfy the conditions, such as shelf life and the elapsed time since first opening the packages.
- (7) This book may be not reprinted or reproduced whether wholly or partially, without the prior written permission of our company.



LittleDiode supplies new, hard to find or obsolete electronic components and semiconductors all over the world.

With over two million different components listed you are sure to find the part you need.

Feel free to visit us today at our online store:

**[LittleDiode.com](http://LittleDiode.com)**

Looking forward to providing you with the best possible service.