

4-channel video-signal PRE/REC amplifier

BA7274S

The BA7274S PRE/REC amplifier has been designed for use in video cassette recorders. It is compatible with four-head decks, and has four head amplifiers, a chroma output amplifier, and FM output amplifier (with AGC circuit), an envelope detector, a fixed-current drive recording amplifier, a channel switch circuit, and record/playback switch integrated only one monolithic IC.

● Applications

VCRs

● Features

- 1) Suitable for 4-head decks.
- 2) Integration of the head-section signal processing circuits (REC and head amplifiers, AGC, and envelope detector) only one IC allows compact deck designs.
- 3) The head amplifier has low input capacitance and low noise ($V_{NIN}=0.4 \mu V_{rms}$), and both the playback and recording systems have a wide frequency range.
- 4) The REX amplifier employs a fixed-output current system to minimize change in the recording current due to load fluctuation. The maximum recording current output is a large $30mA_{P-P}$.
- 5) Built-in channel and record/playback switches (switched to PB V_{CC} and REC V_{CC}).
- 6) Peaking amplifier pin provided for external setting of peak value.
- 7) Compact SDIP 32 pin package.
- 8) Auto-tracking compatible.

● Absolute maximum ratings ($T_a=25^\circ C$)

Parameter	Symbol	Limits		Unit
Power supply voltage	V_{CC}	7 (PRE)	13 (REC)	V
Power dissipation	P_d	1370*		mW
Operating temperature	T_{opr}	-20~70		$^\circ C$
Storage temperature	T_{stg}	-55~150		$^\circ C$

* Reduced by 11.0mW for each increase in T_a of $1^\circ C$ over $25^\circ C$.

● Recommended operating conditions ($T_a=25^\circ C$)

Parameter	Symbol	Min.	Typ.	Max.	Unit	Conditions
Operating supply voltage (playback)	$V_{CC(P)}$	4.5	5.0	5.5	V	25pin
Operating supply voltage (recording)	$V_{CC(R)}$	11.5	12	12.5	V	21pin

* The PRE and REC V_{CC} are used for mode switching. If the PRE and REC V_{CC} voltages are applied together, the amplifier systems and head switch will go on simultaneously causing a large current to flow. This must be avoided, so do not make pins 21 and 25 "H" (0.5V or more) together.

●Electrical characteristics (Unless otherwise specified Ta=25°C)

Parameter	Symbol	Min.	Typ.	Max.	Unit	Conditions
(Playback system) V _{CC} = 5V						
Quiescent current	I _{CC-P}	23	34	44	mA	—
Voltage gain (CH1 to CH4)	G _{VP}	49	57	62	dB	V _{IN} =0.3mV _{P-P} , 100kHz
Maximum chroma output level	V _{OMC}	1.3	1.5	—	V _{P-P}	
AGC output amplitude level	V _{AGC}	130	180	220	mV _{P-P}	
AGC control sensitivity	ΔV _{AGC}	-1.0	1.0	3.0	dB	V _{IN} =0.15~0.6mV _{P-P} , 4MHz
AGC frequency char. (CH1 to CH4)	G _{f1~4}	-2.0	2.0	4.0	dB	V _{IN} =0.3mV _{P-P} , 10MHz / 1MHz
Crosstalk	CT	—	-40	-33	dB	4MHz
Input conversion noise (CH1 to CH4)	V _{N1~4}	—	0.4	1.2	μV _{rms}	
Head switch threshold voltage	V _{TH3}	2.0	2.5	3.0	V	Hi : CH1, 4 Lo : CH2, 3
Head amplifier switch threshold voltage	V _{TH4}	2.0	2.5	3.0	V	Hi : CH3 or 4 Lo : 1 or 2
ENVELOPE comparison output amplitude	V ₂₄	4.3	—	—	V	Hi : CH1 or 2 > CH3 or 4 Lo : CH3 or 4 > CH1 or 2
COMP (ENVE) switch threshold	V _{THP2}	0.3	1.3	1.8	V	Hi : STOP Lo : ENVE OUT
ENVE detector output level SP	V _{ENV-S1}	1.3	1.6	2.1	V	CHROMA OUT=0.0V _{P-P}
ENVE detector output level SP	V _{ENV-S2}	2.6	2.9	3.3	V	CHROMA OUT=0.5V _{P-P} , 4MHz
ENVE detector output level EP	V _{ENV-E1}	1.3	1.6	1.9	V	CHROMA OUT=0.0V _{P-P}
ENVE detector output level EP	V _{ENV-E2}	3.4	3.7	4.1	V	CHROMA OUT=0.5V _{P-P} , 4MHz
PRE switch on resistance	R _{16, 18}	—	5	10	Ω	
(Recording system) V _{CC} = 12V						
Quiescent current	I _{CC-R}	30	47	65	mA	
Maximum output current	I _L	30	—	—	mA _{P-P}	
Recording current secondary distortion	D _L	—	-35	-31	dB	I _L =30mA _{P-P} , 4MHz
Recording current load characteristics	ΔI _L	—	1	3	mA	I _L =30mA, 4MHz, 8.2~15 μH
Recording current frequency char.	G _I	-5	-3	1.5	dB	I _L =10mA, 8MHz / 100kHz
EP/SP switching threshold voltage	V _{THR 2}	0.8	1.3	1.8	V	Hi : EP Lo : SP
REC switch ON resistance	R _{5, 7, 10, 12}	—	10	15	Ω	

●Electrical characteristic curves

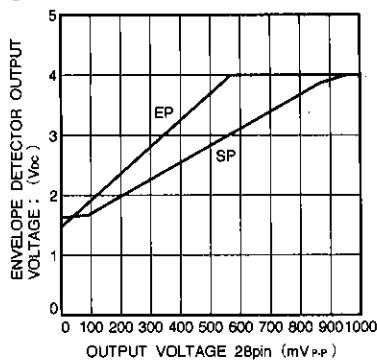

Fig. 1 Playback signal envelope detector characteristics

● Measurement circuit

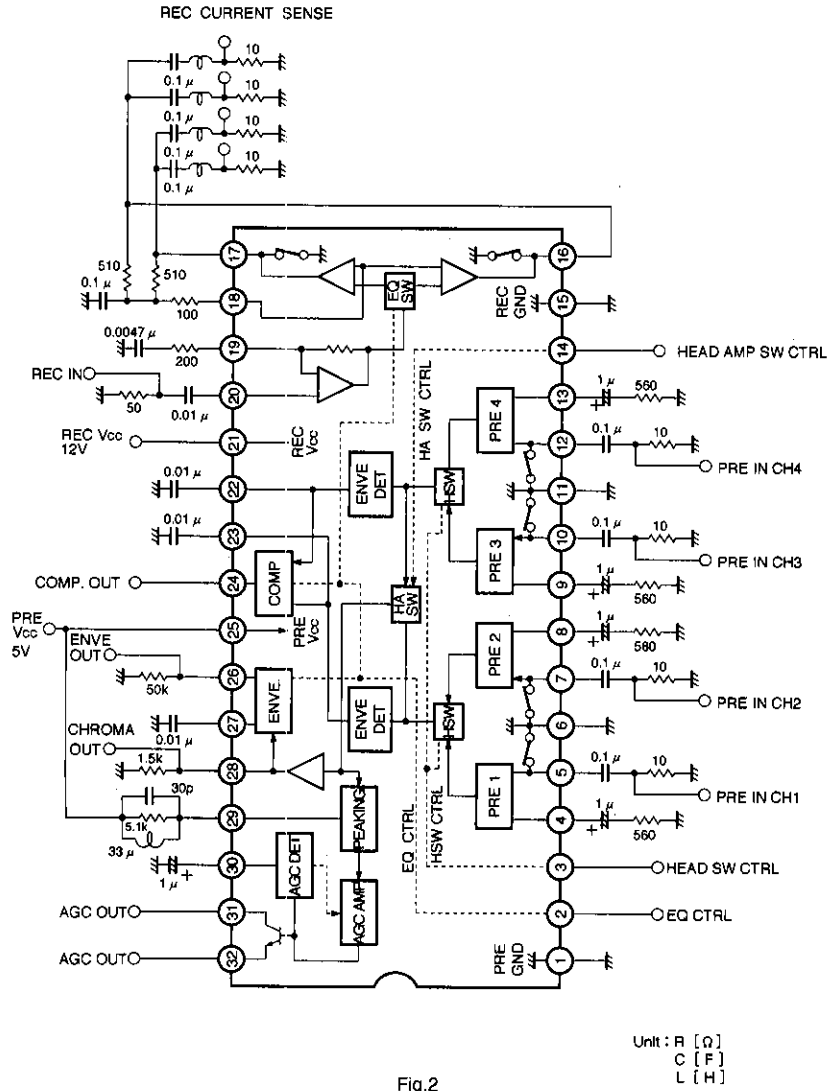

Fig.2

●Control pin logic

(1)Playback head switching

H. AMP SW 14pin	HEAD SW 3pin	Selected head
L	H	CH1 (PRE AMP pin 5 input)
	L	CH2 (PRE AMP pin 7 input)
H	L	CH3 (PRE AMP pin 10 input)
	H	CH4 (PRE AMP pin 12 input)

(2)EP/SP switching envelope comparator ON/OFF switch (pin 2)

REC V _{cc} 21pin	PRE V _{cc} 25pin	EP / SP 2pin	Mode
H (REC)	L	H	EP (REC AMP pin 16 output)
		L	SP (REC AMP pin 17 output)
L	H (PB)	H	ENVE. detector output pin 26 EP mode ENVE. comparator output pin 24 stopped "H"
		L	ENVE. detector output pin 26 SP mode ENVE. comparator output pin 24 operating, see (3)

(3)Envelope comparator output (pin 24)

COMP. OUT 24pin	Conditions
H	CH1 or CH2 output > CH3 or CH4 output
L	CH1 or CH2 output < CH3 or CH4 output

Note: The correspondence between channels and amplifiers is as follows:

CH	CH1	CH2	CH3	CH4
PRE AMP	PRE AMP 1	PRE AMP 2	PRE AMP 3	PRE AMP 4

●Block diagram and application example

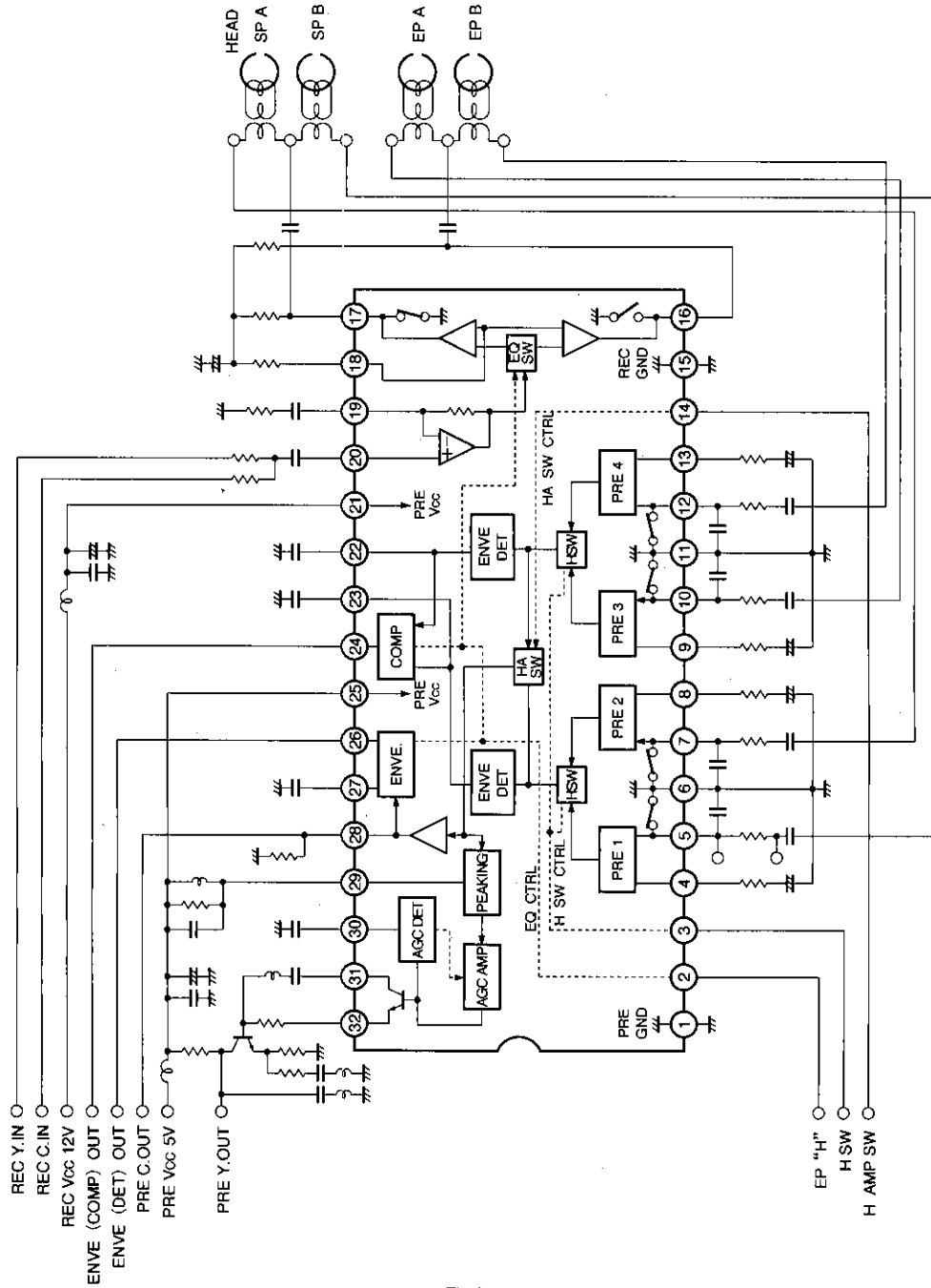
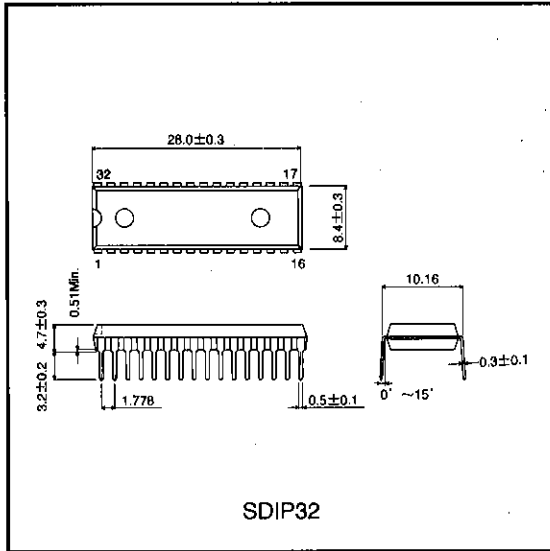

Fig.3

●External dimensions (Units: mm)



VCR components



This datasheet has been downloaded from:

www.DatasheetCatalog.com

Datasheets for electronic components.



LittleDiode supplies new, hard to find or obsolete electronic components and semiconductors all over the world.

With over two million different components listed you are sure to find the part you need.

Feel free to visit us today at our online store:

LittleDiode.com

Looking forward to providing you with the best possible service.