

Hi-Rel NPN bipolar transistor 60 V, 50 mA

Datasheet - production data

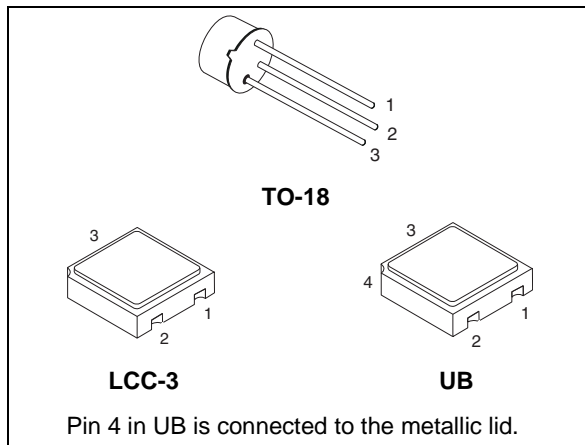
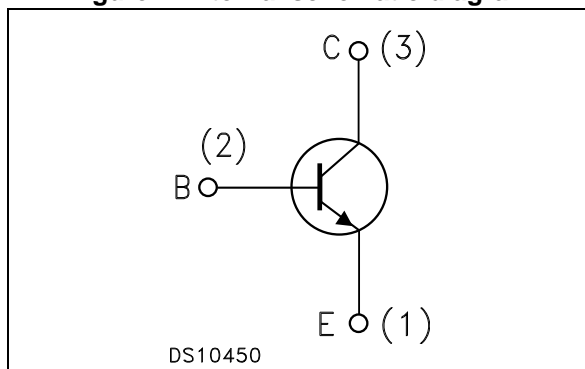

Figure 1. Internal schematic diagram



Features

Parameter	Value
BV_{CEO}	60 V
I_C (max)	50 mA
h_{FE} at 10 V - 150 mA	> 250
Operating temperature range	- 65 °C to + 200 °C

- Linear gain characteristics
- Hermetic packages
- ESCC qualified
- European preferred part list - EPPL

Description

The 2N2484HR is a silicon planar epitaxial NPN transistor specifically designed for aerospace Hi-Rel applications and housed in hermetic packages. It complies with the ESCC 5000 qualification standard. It is ESCC qualified according to the 5201-001 specification. In case of conflict between this datasheet and ESCC detailed specification, the latter prevails.

Table 1. Device summary

Device	Qualification system	Agency specification	Package	Radiation level	EPPL
2N2484UBx	ESCC	5201/001	UB	-	-
SOC2484HRx	ESCC	5201/001	LCC-3	-	Yes
2N2484HRx	ESCC	5201/001	TO-18	-	-

Contents

1	Electrical ratings	3
2	Electrical characteristics	4
3	Test circuit	6
4	Package mechanical data	7
	4.1 LCC-3	7
	4.2 UB	9
	4.3 TO-18	10
5	Order codes	12
6	Revision history	13

1 Electrical ratings

Table 2. Absolute maximum ratings

Symbol	Parameter		Value	Unit
V_{CBO}	Collector-base voltage ($I_E = 0$)		60	V
V_{CEO}	Collector-emitter voltage ($I_B = 0$)		60	V
V_{EBO}	Emitter-base voltage ($I_C = 0$)		6	V
I_C	Collector current		50	mA
P_{TOT}	Total dissipation at $T_{amb} \leq 25\text{ °C}$	2N2484HR	0.36	W
		2N2484UB1 / SOC2484HRB	0.36	W
		2N2484UB1 / SOC2484HRB ⁽¹⁾	0.73	W
P_{TOT}	Total dissipation at $T_C \leq 25\text{ °C}$	2N2484HR	1.2	W
T_{STG}	Storage temperature		- 65 to 200	°C
T_J	Max. operating junction temperature		200	°C

1. When mounted on a 15 x 15 x 0.6 mm ceramic substrate.

Table 3. Thermal data for through-hole package

Symbol	Parameter	TO-18	Unit
R_{thJC}	Thermal resistance junction-case max	146	°C/W
R_{thJA}	Thermal resistance junction-ambient max	486	°C/W

Table 4. Thermal data for SMD package

Symbol	Parameter	LCC-3 LCC-3UB	Unit
R_{thJA}	Thermal resistance junction-ambient max	486	°C/W
	Thermal resistance junction-ambient ⁽¹⁾ max	239	

1. When mounted on a 15 x 15 x 0.6 mm ceramic substrate.

2 Electrical characteristics

$T_{\text{case}} = 25\text{ }^{\circ}\text{C}$ unless otherwise specified.

Table 5. Electrical characteristics

Symbol	Parameter	Test conditions ⁽¹⁾	Min.	Typ.	Max.	Unit
$V_{(\text{BR})\text{CBO}}$	Collector-base breakdown voltage	$I_{\text{C}} = 10\text{ }\mu\text{A}$	60	-		V
$V_{(\text{BR})\text{CEO}}^{(2)}$	Collector-emitter breakdown voltage	$I_{\text{C}} = 10\text{ mA}$	60	-		V
$V_{(\text{BR})\text{EBO}}$	Emitter-base breakdown voltage	$I_{\text{E}} = 10\text{ }\mu\text{A}$	6	-		V
I_{CBO}	Collector-base cut-off current	$V_{\text{CB}} = 45\text{ V}$		-	10	nA
I_{CBO}	Emitter-base cut-off current	$V_{\text{EB}} = 5\text{ V}$		-	10	nA
$V_{\text{CE}(\text{sat})}^{(2)}$	Collector-emitter saturation voltage	$I_{\text{C}} = 1\text{ mA}, I_{\text{B}} = 0.1\text{ mA}$		-	0.35	V
$h_{\text{FE}}^{(2)}$	DC forward current transfer ratio	$I_{\text{C}} = 1\text{ }\mu\text{A}, V_{\text{CE}} = 5\text{ V}$	30	-	500	
		$I_{\text{C}} = 10\text{ }\mu\text{A}, V_{\text{CE}} = 5\text{ V}$	100			
		$I_{\text{C}} = 100\text{ }\mu\text{A}, V_{\text{CE}} = 5\text{ V}$	175			
		$I_{\text{C}} = 1\text{ mA}, V_{\text{CE}} = 5\text{ V}$	250			
		$I_{\text{C}} = 10\text{ mA}, V_{\text{CE}} = 5\text{ V}$				
h_{fe}	High frequency current Gain 1	$V_{\text{CE}} = 5\text{ V}, I_{\text{C}} = 50\text{ }\mu\text{A}, f = 5\text{ MHz}$	3	-		
	High frequency current Gain 2	$V_{\text{CE}} = 5\text{ V}, I_{\text{C}} = 500\text{ }\mu\text{A}, f = 30\text{ MHz}$	2			
C_{obo}	Output capacitance	$V_{\text{CB}} = 5\text{ V}, I_{\text{E}} = 0, f = 1\text{ MHz}$		-	6	pF
C_{ibo}	Input capacitance	$V_{\text{EB}} = 0.5\text{ V}, I_{\text{C}} = 0, f = 1\text{ MHz}$		-	6	pF
h_{FE}	Small signal current gain	$I_{\text{C}} = 1\text{ mA}, V_{\text{CE}} = 5\text{ V}, f = 1\text{ kHz}$	150	-	900	
h_{ie}	Small signal input impedance	$I_{\text{C}} = 1\text{ mA}, V_{\text{CE}} = 5\text{ V}, f = 1\text{ kHz}$	3.5	-	24	k Ω
h_{oc}	Small signal output impedance	$I_{\text{C}} = 1\text{ mA}, V_{\text{CE}} = 5\text{ V}, f = 1\text{ kHz}$		-	40	$\mu\Omega$
h_{re}	Small signal reverse voltage transfer ratio	$I_{\text{C}} = 1\text{ mA}, V_{\text{CE}} = 5\text{ V}, f = 1\text{ kHz}$		-	800	10^{-6}
N_{FW}	Wide-Band noise	$V_{\text{CE}} = 5\text{ V}, I_{\text{C}} = 10\text{ }\mu\text{A}, R_{\text{S}} = 10\text{ k}\Omega$		-	3	dB

Table 5. Electrical characteristics (continued)

Symbol	Parameter	Test conditions ⁽¹⁾	Min.	Typ.	Max.	Unit
NF _{N1}	Spot noise figure	V _{CE} = 5 V, I _C = 10 μA R _S = 10 kΩ, f = 100 Hz Power BW = 200 Hz	-	-	3	dB
NF _{N2}		V _{CE} = 5 V, I _C = 10 μA R _S = 10 kΩ, f = 1 kHz Power BW = 20 Hz	-	-	10	
NF _{N3}		V _{CE} = 5 V, I _C = 10 μA R _S = 10 kΩ, f = 10 kHz Power BW = 2 Hz	-	-	2	

1. Measurement performed on a sample basis, LTPD 7 or less.
2. Pulse measurement: Pulse width ≤ 300 μs, duty cycle ≤ 1.0 %

Table 6. Electrical characteristics at high and low temperatures

Symbol	Parameter	Test conditions	Min.	Typ.	Max.	Unit
I _{CBO}	Collector-base cut-off current	V _{CB} = 45 V, T _{amb} = 150 °C		-	10	μA
h _{FE2}	DC forward current transfer ratio	I _C = 10 μA, V _{CE} = 5 V T _{amb} = - 55 °C	20	-		

3 Test circuit

Figure 2. Circuit for electrical measurements

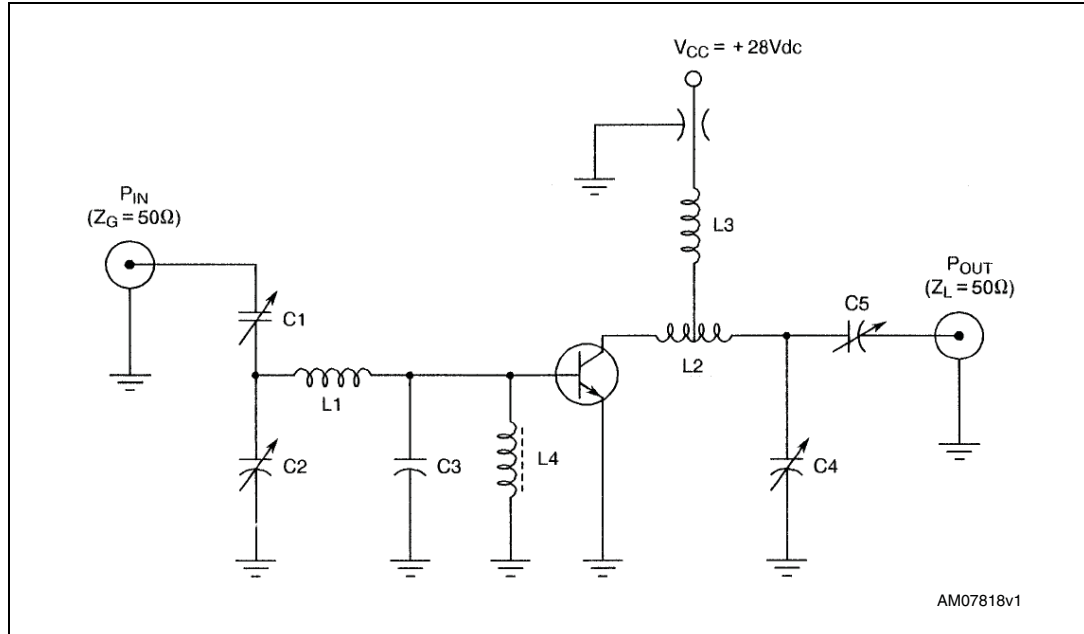

Table 7. List of components

Component	Description
C1, C2, C5	3.0 - 35 pF
C3 ⁽¹⁾	24 pF
C4	0.4 - 7.0 pF
L1	Straight piece n° 16 bare tin wire, 5/8 inch long
L2	3 turns n° 16 wire, 1/4 inch ID, 5/16 inch long
L3	1 turn n° 18 wire, 1/4 inch ID, 1/4 inch long
L4	Ferrite rf choke, Z = 450 Ω

1. For optimum performance, C3 should be mounted as close as possible to the base lead.

4 Package mechanical data

In order to meet environmental requirements, ST offers these devices in different grades of ECOPACK[®] packages, depending on their level of environmental compliance. ECOPACK[®] specifications, grade definitions and product status are available at: www.st.com. ECOPACK[®] is an ST trademark.

4.1 LCC-3

Figure 3. LCC-3 drawings

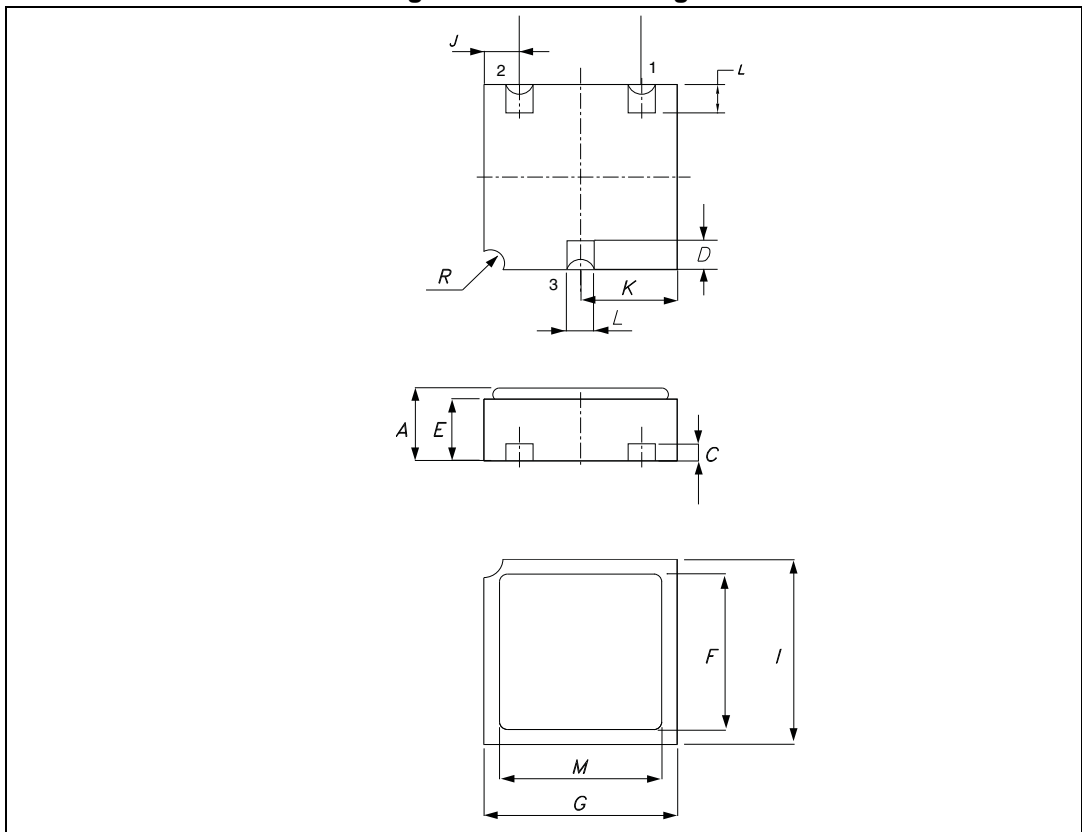

Table 8. LCC-3 mechanical data

Dim.	mm.		
	Min.	Typ.	Max.
A	1.16		1.42
C	0.45	0.50	0.56
D	0.60	0.76	0.91
E	0.91	1.01	1.12
F	1.95	2.03	2.11
G	2.92	3.05	3.17
I	2.41	2.54	2.66
J	0.42	0.57	0.72
K	1.37	1.52	1.67
L	0.40	0.50	0.60
M	2.46	2.54	2.62
N	1.80	1.90	2.00
R		0.30	

4.2 UB

Table 9. UB mechanical data

Dim.	mm.		
	Min.	Typ.	Max.
A	1.16		1.42
C	0.46	0.51	0.56
D	0.56	0.76	0.96
E	0.92	1.02	1.12
F	1.95	2.03	2.11
G	2.92	3.05	3.18
I	2.41	2.54	2.67
J	0.42	0.57	0.72
K	1.37	1.52	1.67
L	0.41	0.51	0.61
M	2.46	2.54	2.62
N	1.81	1.91	2.01
r		0.20	
r1		0.30	
r2		0.56	

Figure 4. LCC-3UB drawings

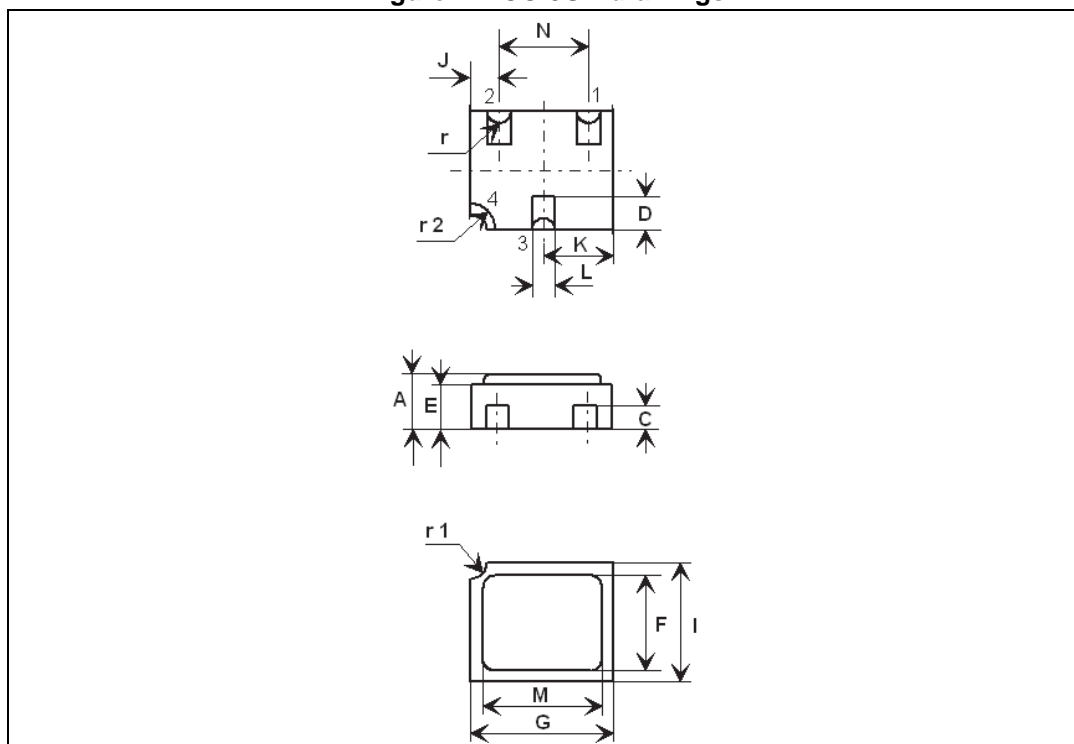

4.3 TO-18

Table 10. TO-18 mechanical data

Dim.	mm.		
	Min.	Typ.	Max.
A		12.7	
B			0.49
D			5.3
E			4.9
F			5.8
G	2.54		
H			1.2
I			1.16
L	45°		

Figure 5. TO-18 drawings

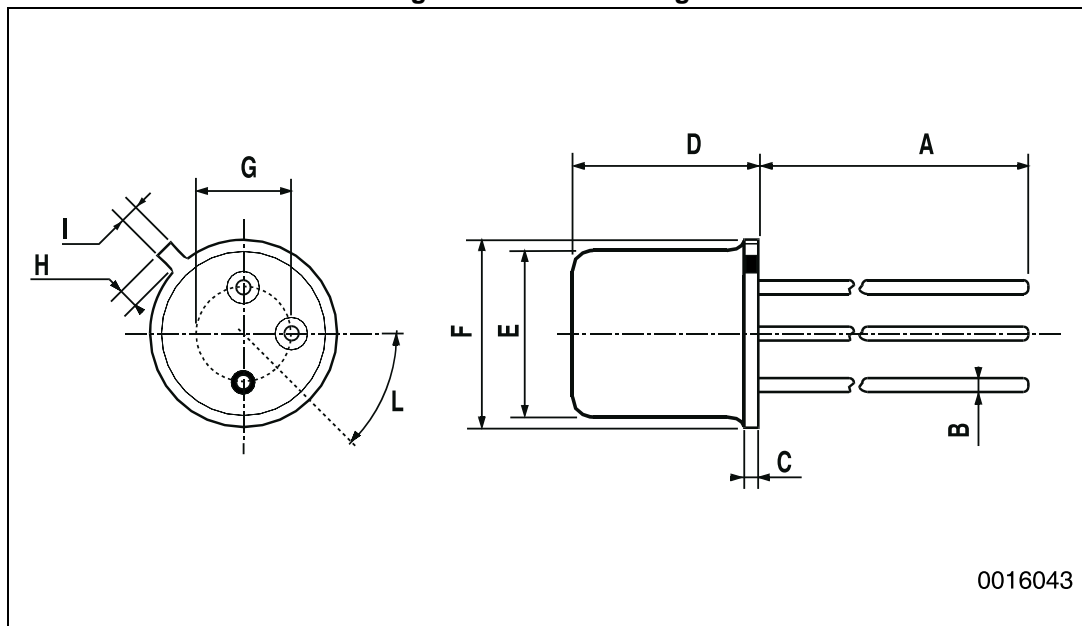

0016043

5 Order codes

Table 11. Order codes

CPN	Agency specification	EPPL	Quality level	Radiation level	Package	Lead finish	Marking ⁽¹⁾	Packing
2N2484UB1	-	-	Engineering model ESCC	-	UB	Gold	2N2484UB1	WafflePack
SOC24841	-	-	Engineering model ESCC	-	LCC-3	Gold	SOC24841	WafflePack
2N2484UBG	5201/001/06	-	ESCC	-	UB	Gold	520100106	WafflePack
2N2484UBT	5201/001/07	-	ESCC	-	UB	Solder Dip	520100107	WafflePack
SOC2484HRG	5201/001/04	-	ESCC	-	LCC-3	Gold	520100104	WafflePack
SOC2484HRT	5201/001/05	Yes	ESCC	-	LCC-3	Solder Dip	520100105	WafflePack
2N2484HRG	5201/001/01	-	ESCC	-	TO-18	Gold	520100101	Strip Pack
2N2484HRT	5201/001/02	-	ESCC	-	TO-18	Solder Dip	520100102	Strip Pack

1. Specific marking only. The full marking includes in addition:
 For the Engineering Models: ST logo, date code; country of origin (FR).
 For ESCC flight parts: ST logo, date code, country of origin (FR), ESA logo, serial number of the part within the assembly lot.

Contact ST sales office for information about the specific conditions for:

- Products in die form
- Tape and reel packing

6 Revision history

Table 12. Document revision history

Date	Revision	Changes
09-Jul-2010	1	Initial release.
26-Feb-2013	2	Updated: Table 1: Device summary and Table 11: Order codes .
01-Apr-2014	3	Updated: Table 1: Device summary and Table 11: Order codes . Minor text changes.

Please Read Carefully:

Information in this document is provided solely in connection with ST products. STMicroelectronics NV and its subsidiaries ("ST") reserve the right to make changes, corrections, modifications or improvements, to this document, and the products and services described herein at any time, without notice.

All ST products are sold pursuant to ST's terms and conditions of sale.

Purchasers are solely responsible for the choice, selection and use of the ST products and services described herein, and ST assumes no liability whatsoever relating to the choice, selection or use of the ST products and services described herein.

No license, express or implied, by estoppel or otherwise, to any intellectual property rights is granted under this document. If any part of this document refers to any third party products or services it shall not be deemed a license grant by ST for the use of such third party products or services, or any intellectual property contained therein or considered as a warranty covering the use in any manner whatsoever of such third party products or services or any intellectual property contained therein.

UNLESS OTHERWISE SET FORTH IN ST'S TERMS AND CONDITIONS OF SALE ST DISCLAIMS ANY EXPRESS OR IMPLIED WARRANTY WITH RESPECT TO THE USE AND/OR SALE OF ST PRODUCTS INCLUDING WITHOUT LIMITATION IMPLIED WARRANTIES OF MERCHANTABILITY, FITNESS FOR A PARTICULAR PURPOSE (AND THEIR EQUIVALENTS UNDER THE LAWS OF ANY JURISDICTION), OR INFRINGEMENT OF ANY PATENT, COPYRIGHT OR OTHER INTELLECTUAL PROPERTY RIGHT.

ST PRODUCTS ARE NOT DESIGNED OR AUTHORIZED FOR USE IN: (A) SAFETY CRITICAL APPLICATIONS SUCH AS LIFE SUPPORTING, ACTIVE IMPLANTED DEVICES OR SYSTEMS WITH PRODUCT FUNCTIONAL SAFETY REQUIREMENTS; (B) AERONAUTIC APPLICATIONS; (C) AUTOMOTIVE APPLICATIONS OR ENVIRONMENTS, AND/OR (D) AEROSPACE APPLICATIONS OR ENVIRONMENTS. WHERE ST PRODUCTS ARE NOT DESIGNED FOR SUCH USE, THE PURCHASER SHALL USE PRODUCTS AT PURCHASER'S SOLE RISK, EVEN IF ST HAS BEEN INFORMED IN WRITING OF SUCH USAGE, UNLESS A PRODUCT IS EXPRESSLY DESIGNATED BY ST AS BEING INTENDED FOR "AUTOMOTIVE, AUTOMOTIVE SAFETY OR MEDICAL" INDUSTRY DOMAINS ACCORDING TO ST PRODUCT DESIGN SPECIFICATIONS. PRODUCTS FORMALLY ESCC, QML OR JAN QUALIFIED ARE DEEMED SUITABLE FOR USE IN AEROSPACE BY THE CORRESPONDING GOVERNMENTAL AGENCY.

Resale of ST products with provisions different from the statements and/or technical features set forth in this document shall immediately void any warranty granted by ST for the ST product or service described herein and shall not create or extend in any manner whatsoever, any liability of ST.

ST and the ST logo are trademarks or registered trademarks of ST in various countries.

Information in this document supersedes and replaces all information previously supplied.

The ST logo is a registered trademark of STMicroelectronics. All other names are the property of their respective owners.

© 2014 STMicroelectronics - All rights reserved

STMicroelectronics group of companies

Australia - Belgium - Brazil - Canada - China - Czech Republic - Finland - France - Germany - Hong Kong - India - Israel - Italy - Japan - Malaysia - Malta - Morocco - Philippines - Singapore - Spain - Sweden - Switzerland - United Kingdom - United States of America

www.st.com



LittleDiode supplies new, hard to find or obsolete electronic components and semiconductors all over the world.

With over two million different components listed you are sure to find the part you need.

Feel free to visit us today at our online store:

LittleDiode.com

Looking forward to providing you with the best possible service.