

MITSUBISHI RF POWER TRANSISTOR

2SC2538

NPN EPITAXIAL PLANAR TYPE

DESCRIPTION

2SC2538 is a silicon NPN epitaxial planar type transistor designed for RF amplifiers on VHF band mobile radio applications.

FEATURES

- High power gain: $G_{pe} \geq 10\text{dB}$
@ $V_{CC} = 13.5\text{V}$, $P_O = 0.5\text{W}$, $f = 175\text{MHz}$
- TO-92 similar package is convenient for mounting.
- Equivalent input/output series impedance:
 $Z_{in} = 5.25 - j3.9\Omega$ @ $V_{CC} = 13.5\text{V}$, $P_O = 500\text{mW}$, $f = 175\text{MHz}$
 $Z_{out} = 29 - j63.5\Omega$

APPLICATION

Driver amplifiers in general VHF band mobile radio applications.

OUTLINE DRAWING

Dimensions in mm

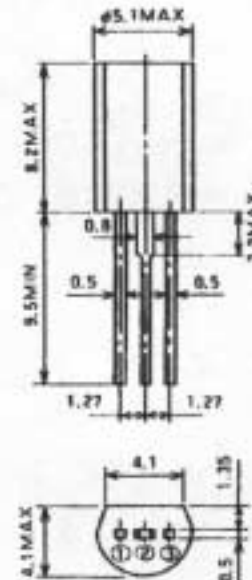

PIN :
① BASE
② COLLECTOR
③ EMITTER

TO-92L

ABSOLUTE MAXIMUM RATINGS ($T_C = 25^\circ\text{C}$ unless otherwise specified)

Symbol	Parameter	Conditions	Rating	Unit
V_{CBO}	Collector to base voltage		40	V
V_{EBO}	Emitter to base voltage		4	V
V_{CEO}	Collector to emitter voltage	$R_{BE} = \infty$	17	V
I_C	Collector current		0.4	A
P_O	Collector dissipation	$T_B = 25^\circ\text{C}$	0.7	W
		$T_C = 25^\circ\text{C}$	3	W
T_j	Junction temperature		135	$^\circ\text{C}$
T_{stg}	Storage temperature		-55 to 135	$^\circ\text{C}$
R_{th-a}	Thermal resistance	Junction to ambient	157	$^\circ\text{C}/\text{W}$
		Junction to case	36.7	$^\circ\text{C}/\text{W}$

Note: Above parameters are guaranteed independently.

ELECTRICAL CHARACTERISTICS ($T_C = 25^\circ\text{C}$ unless otherwise specified)

Symbol	Parameter	Test conditions	Limits			Unit
			Min	Typ	Max	
$V_{(BR)EBO}$	Emitter to base breakdown voltage	$I_E = 1\text{mA}$, $I_C = 0$	4			V
$V_{(BR)CBO}$	Collector to base breakdown voltage	$I_C = 1\text{mA}$, $I_E = 0$	40			V
$V_{(BR)CEO}$	Collector to emitter breakdown voltage	$I_C = 10\text{mA}$, $R_{BE} = \infty$	17			V
I_{CBO}	Collector cutoff current	$V_{CB} = 15\text{V}$, $I_E = 0$			100	μA
I_{EBO}	Emitter cutoff current	$V_{EB} = 3\text{V}$, $I_C = 0$			200	μA
h_{FE}	DC forward current gain*	$V_{CE} = 10\text{V}$, $I_C = 0.1\text{A}$	10	80	300	—
P_O	Output power	$V_{CC} = 13.5\text{V}$, $P_{in} = 50\text{mW}$, $f = 175\text{MHz}$	500	600		mW
η_C	Collector efficiency		45	55		%

Note: * Pulse test. $P_w = 150\text{W}$, duty = 5%.

Above parameters, ratings, limits and conditions are subject to change.

TEST CIRCUIT

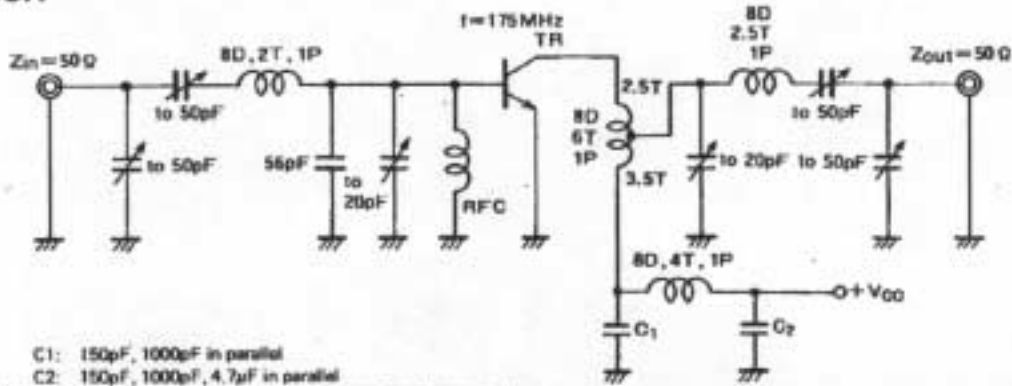

- C1: 150pF, 1000pF in parallel
 C2: 150pF, 1000pF, 4.7μF in parallel
 NOTES: All coils are made from 1.5mmφ silver plated copper wire
 Coil Dimensions in milli-meter
 D: Inner diameter of coil
 T: Turn number of coil
 P: Pitch of coil

TYPICAL PERFORMANCE DATA

COLLECTOR DISSIPATION VS. AMBIENT TEMPERATURE

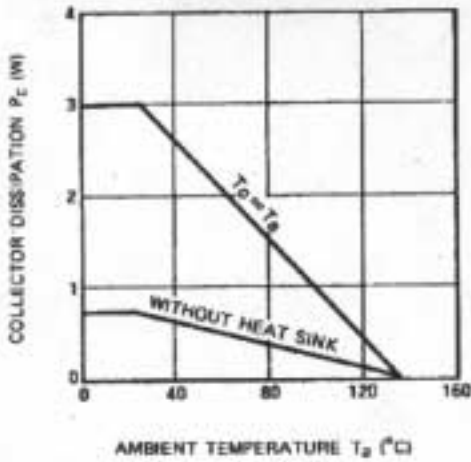

COLLECTOR CURRENT VS. COLLECTOR TO EMITTER VOLTAGE

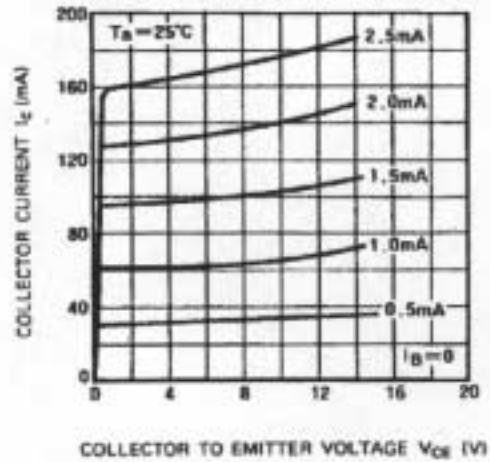

COLLECTOR TO EMITTER BREAKDOWN VOLTAGE VS. BASE TO EMITTER RESISTANCE

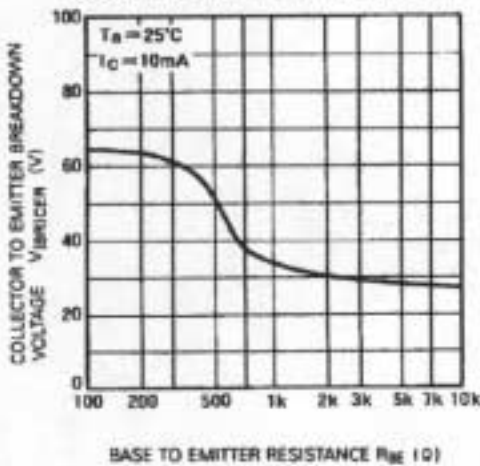

DC CURRENT GAIN VS. COLLECTOR CURRENT

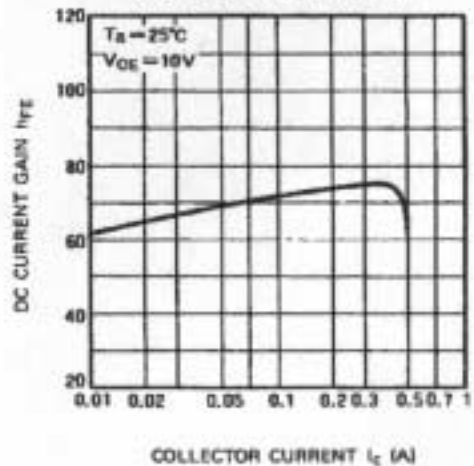

MITSUBISHI RF POWER TRANSISTOR
2SC2538

NPN EPITAXIAL PLANAR TYPE

COLLECTOR OUTPUT CAPACITANCE VS. COLLECTOR TO BASE VOLTAGE

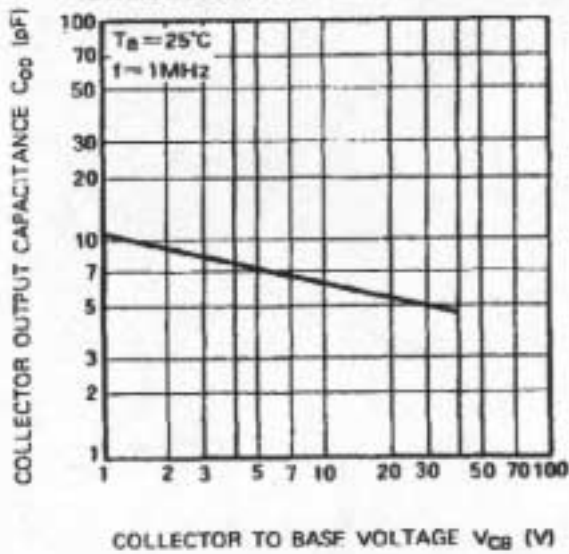

OUTPUT POWER, COLLECTOR EFFICIENCY VS. INPUT POWER

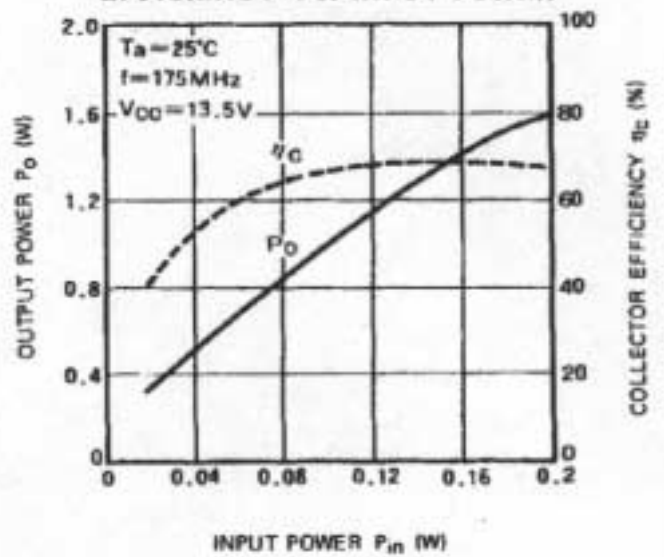

OUTPUT POWER VS. COLLECTOR SUPPLY VOLTAGE

