

9097250 TOSHIBA (DISCRETE/OPTO)

56C 07803

DT-33-11

2SD820

SILICON NPN TRIPLE DIFFUSED MESA TYPE

COLOR TV HORIZONTAL OUTPUT APPLICATIONS.

FEATURES:

- High Voltage : $V_{CB0}=1500V$
- Low Saturation Voltage
: $V_{CE(sat)}=5V$ (Max.) ($I_C=4A, I_B=0.8A$)
- High Speed : $t_f=1.0\mu s$ (Max.)
- Glass Passivated Collector-Base Junction.

MAXIMUM RATINGS ($T_a=25^\circ C$)

CHARACTERISTIC	SYMBOL	RATING	UNIT
Collector-Base Voltage	V_{CB0}	1500	V
Collector-Emitter Voltage	V_{CEO}	600	V
Emitter-Base Voltage	V_{EBO}	5	V
Collector Current	I_C	5	A
Emitter Current	I_E	-5	A
Collector Power Dissipation ($T_c=25^\circ C$)	P_C	50	W
Junction Temperature	T_j	150	$^\circ C$
Storage Temperature Range	T_{stg}	-65~150	$^\circ C$

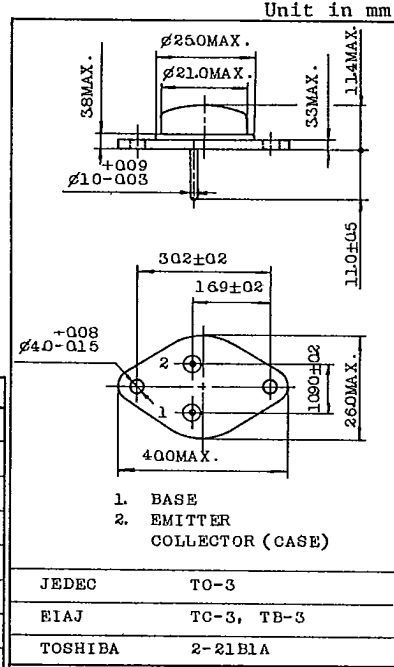

Mounting kit No. AC42C
Weight : 17g

ELECTRICAL CHARACTERISTICS ($T_a=25^\circ C$)

CHARACTERISTIC	SYMBOL	TEST CONDITION	MIN.	TYP.	MAX.	UNIT
Collector Cut-off Current	I_{CB0}	$V_{CB}=500V, I_E=0$	-	-	10	μA
Emitter Cut-off Current	I_{EBO}	$V_{EB}=5V, I_C=0$	-	-	1	mA
DC Current Gain	h_{FE}	$V_{CE}=5V, I_C=1A$	8	20	-	-
Collector-Emitter Saturation Voltage	$V_{CE(sat)}$	$I_C=4A, I_B=0.8A$	-	3	5	V
Base-Emitter Saturation Voltage	$V_{BE(sat)}$	$I_C=4A, I_B=0.8A$	-	-	1.5	V
Transition Frequency	f_T	$V_{CE}=10V, I_C=0.1A$	-	3	-	MHz
Collector Output Capacitance	C_{ob}	$V_{CB}=10V, I_E=0, f=1MHz$	-	165	-	pF
Fall Time (Fig.)	t_f	$I_{CP}=4A, I_{B1}(end)=0.8A$	-	0.5	1.0	μs

Fig. t_f TEST CIRCUIT

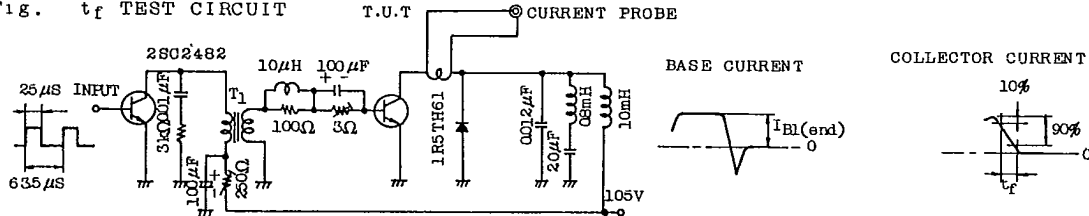

TOSHIBA CORPORATION