

74F113 Dual JK Negative Edge-Triggered Flip-Flop

General Description

The 74F113 offers individual J, K, Set and Clock inputs. When the clock goes HIGH the inputs are enabled and data may be entered. The logic level of the J and K inputs may be changed when the clock pulse is HIGH and the flip-flop will perform according to the Truth Table as long as minimum setup and hold times are observed. Input data is

transferred to the outputs on the falling edge of the clock pulse.

Asynchronous input:

LOW input to \bar{S}_D sets Q to HIGH level

Set is independent of clock

Ordering Code:

Order Number	Package Number	Package Description
74F113SC	M14A	14-Lead Small Outline Integrated Circuit (SOIC), JEDEC MS-120, 0.150 Narrow
74F113SJ	M14D	14-Lead Small Outline Package (SOP), EIAJ TYPE II, 5.3mm Wide
74F113PC	N14A	14-Lead Plastic Dual-In-Line Package (PDIP), JEDEC MS-001, 0.300 Wide

Devices also available in Tape and Reel. Specify by appending the suffix letter "X" to the ordering code.

Logic Symbols

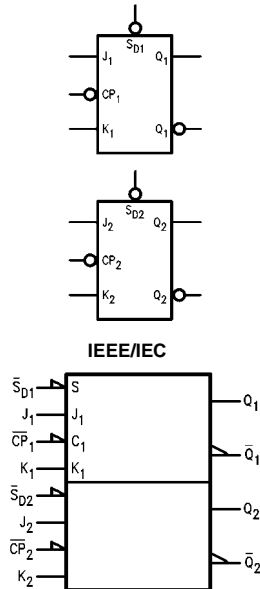

Connection Diagram

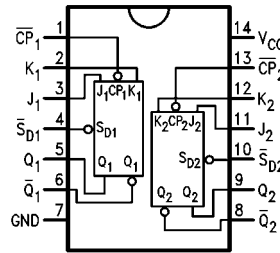

Unit Loading/Fan Out

Pin Names	Description	U.L. HIGH/LOW	Input I_{IH}/I_{IL} Output I_{OH}/I_{OL}
J_1, J_2, K_1, K_2	Data Inputs	1.0/1.0	20 μ A/-0.6 mA
$\overline{CP}_1, \overline{CP}_2$	Clock Pulse Inputs (Active Falling Edge)	1.0/4.0	20 μ A/-2.4 mA
$\overline{SD}_1, \overline{SD}_2$	Direct Set Inputs (Active LOW)	1.0/5.0	20 μ A/-3.0 mA
$Q_1, Q_2, \overline{Q}_1, \overline{Q}_2$	Outputs	50/33.3	-1 mA/20 mA

Truth Table

Inputs				Outputs	
\overline{S}_D	\overline{CP}	J	K	Q	\overline{Q}
L	X	X	X	H	L
H	\sim	h	h	\overline{Q}_0	Q_0
H	\sim	l	h	L	H
H	\sim	h	l	H	L
H	\sim	l	l	Q_0	\overline{Q}_0

H (h) = HIGH Voltage Level
 L (l) = LOW Voltage level
 \sim = HIGH-to-LOW Clock Transition
 X = Immaterial
 Q_0 (\overline{Q}_0) = Before HIGH-to-LOW Transition of Clock
 Lower case letters indicate the state of the referenced input or output prior to the HIGH-to-LOW clock transition.

Logic Diagram

(One Half Shown)

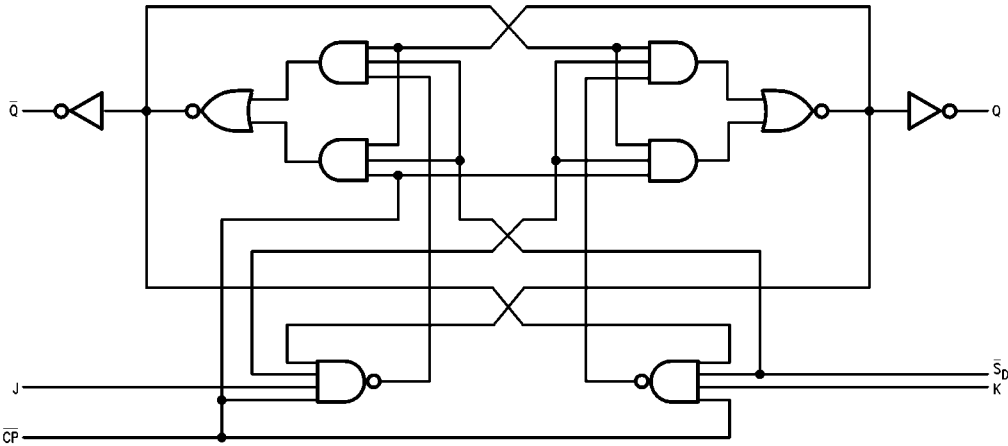

Please note that this diagram is provided only for the understanding of logic operations and should not be used to estimate propagation delays.

Absolute Maximum Ratings(Note 1)

Storage Temperature	-65°C to +150°C
Ambient Temperature under Bias	-55°C to +125°C
Junction Temperature under Bias	-55°C to +150°C
V _{CC} Pin Potential to Ground Pin	-0.5V to +7.0V
Input Voltage (Note 2)	-0.5V to +7.0V
Input Current (Note 2)	-30 mA to +5.0 mA

Voltage Applied to Output

in HIGH State (with V_{CC} = 0V)Standard Output -0.5V to V_{CC}

3-STATE Output -0.5V to +5.5V

Current Applied to Output

in LOW State (Max) twice the rated I_{OL} (mA)**Recommended Operating Conditions**

Free Air Ambient Temperature	0°C to +70°C
Supply Voltage	+4.5V to +5.5V

Note 1: Absolute maximum ratings are values beyond which the device may be damaged or have its useful life impaired. Functional operation under these conditions is not implied.

Note 2: Either voltage limit or current limit is sufficient to protect inputs.

DC Electrical Characteristics

Symbol	Parameter	Min	Typ	Max	Units	V _{CC}	Conditions
V _{IH}	Input HIGH Voltage	2.0			V		Recognized as a HIGH Signal
V _{IL}	Input LOW Voltage			0.8	V		Recognized as a LOW Signal
V _{CD}	Input Clamp Diode Voltage			-1.2	V	Min	I _{IN} = -18 mA
V _{OH}	Output HIGH Voltage	10% V _{CC}	2.5		V	Min	I _{OH} = -1 mA
		5% V _{CC}	2.7				I _{OH} = -1 mA
V _{OL}	Output LOW Voltage			0.5	V	Min	I _{OL} = 20 mA
I _{IH}	Input HIGH Current			5.0	μA	Max	V _{IN} = 2.7V
I _{BV1}	Input HIGH Current Breakdown Test			7.0	μA	Max	V _{IN} = 7.0V
I _{CEx}	Output HIGH Leakage Current			50	μA	Max	V _{OUT} = V _{CC}
V _{ID}	Input Leakage Test	4.75			V	0.0	I _{ID} = 1.9 μA All Other Pins Grounded
I _{OD}	Output Leakage Circuit Current			3.75	μA	0.0	V _{IOD} = 150 mV All Other Pins Grounded
I _{IL}	Input LOW Current			-0.6	mA	Max	V _{IN} = 0.5V (J _n , K _n) V _{IN} = 0.5V (CP _n) V _{IN} = 0.5V (SD _n)
				-2.4			
				-3.0			
I _{OZH}	Output Leakage Current			50	μA	Max	V _{OUT} = 2.7V
I _{OZL}	Output Leakage Current			-50	μA	Max	V _{OUT} = 0.5V
I _{OS}	Output Short-Circuit Current	-60		-150	mA	Max	V _{OUT} = 0V
I _{CC}	Power Supply Current		12	19	mA	Max	

AC Electrical Characteristics							
Symbol	Parameter	T _A = +25°C V _{CC} = +5.0V C _L = 50 pF			T _A = 0°C to +70°C V _{CC} = +5.0V C _L = 50 pF		Units
		Min	Typ	Max	Min	Max	
f _{MAX}	Maximum Clock Frequency	85	105		80		MHz
t _{PLH}	Propagation Delay	2.0	4.0	6.0	2.0	7.0	ns
t _{PHL}	\overline{CP}_n to Q _n or \overline{Q}_n	2.0	4.0	6.0	2.0	7.0	
t _{PLH}	Propagation Delay	2.0	4.5	6.5	2.0	7.5	ns
t _{PHL}	\overline{SD}_n to Q _n or \overline{Q}_n	2.0	4.5	6.5	2.0	7.5	
AC Operating Requirements							
Symbol	Parameter	T _A = +25°C V _{CC} = +5.0V		T _A = 0°C to +70°C V _{CC} = +5.0V		Units	
		Min	Max	Min	Max		
t _S (H)	Setup Time, HIGH or LOW	4.0		5.0		ns	
t _S (L)	J _n or K _n to \overline{CP}_n	3.0		3.5			
t _H (H)	Hold Time, HIGH or LOW	0		0		ns	
t _H (L)	J _n or K _n to \overline{CP}_n	0		0			
t _W (H)	\overline{CP}_n Pulse Width	4.5		5.0		ns	
t _W (L)	HIGH or LOW	4.5		5.0			
t _W (L)	\overline{SD}_n Pulse Width, LOW	4.5		5.0		ns	
t _{REC}	\overline{SD}_n to \overline{CP}_n Recovery Time	4.0		5.0		ns	

Physical Dimensions inches (millimeters) unless otherwise noted

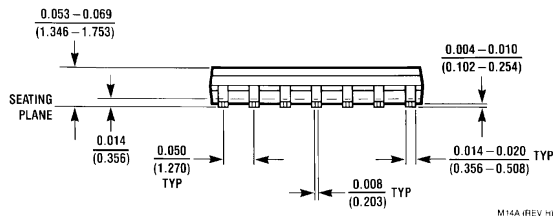
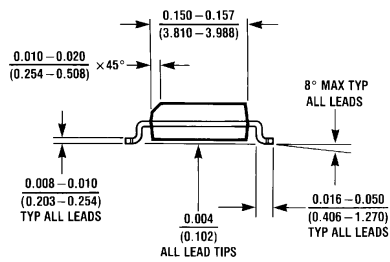
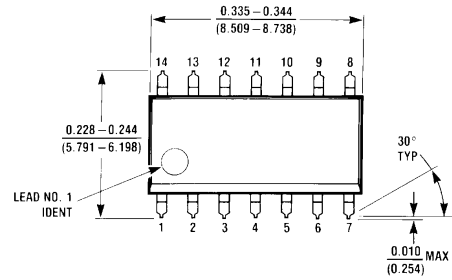

M14A (REV H)

**14-Lead Small Outline Integrated Circuit (SOIC), JEDEC MS-120, 0.150 Narrow
Package Number M14A**

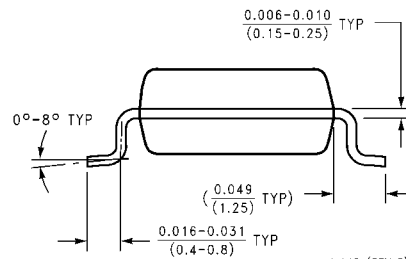
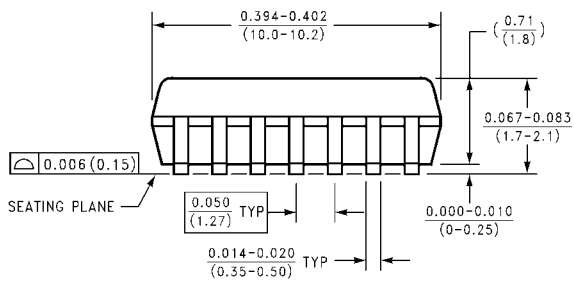
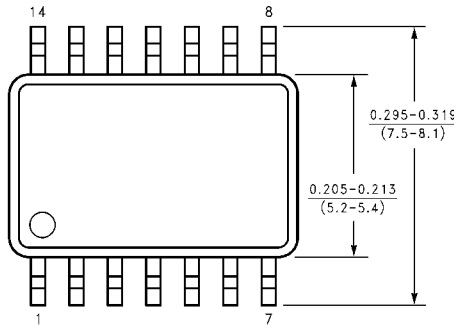

M14D (REV B)

**14-Lead Small Outline Package (SOP), EIAJ TYPE II, 5.3mm Wide
Package Number M14D**

Physical Dimensions inches (millimeters) unless otherwise noted (Continued)

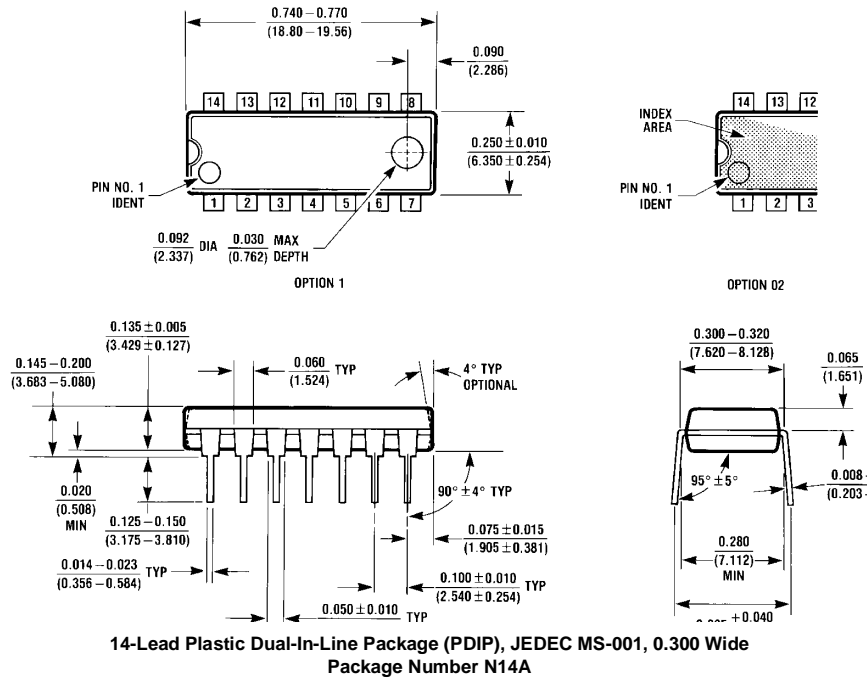

Fairchild does not assume any responsibility for use of any circuitry described, no circuit patent licenses are implied and Fairchild reserves the right at any time without notice to change said circuitry and specifications.

LIFE SUPPORT POLICY

FAIRCHILD'S PRODUCTS ARE NOT AUTHORIZED FOR USE AS CRITICAL COMPONENTS IN LIFE SUPPORT DEVICES OR SYSTEMS WITHOUT THE EXPRESS WRITTEN APPROVAL OF THE PRESIDENT OF FAIRCHILD SEMICONDUCTOR CORPORATION. As used herein:

1. Life support devices or systems are devices or systems which, (a) are intended for surgical implant into the body, or (b) support or sustain life, and (c) whose failure to perform when properly used in accordance with instructions for use provided in the labeling, can be reasonably expected to result in a significant injury to the user.
2. A critical component in any component of a life support device or system whose failure to perform can be reasonably expected to cause the failure of the life support device or system, or to affect its safety or effectiveness.

www.fairchildsemi.com