



# DZ23C2V7 THRU DZ23C51

## Dual Surface Mount Zener Diode



Voltage Range  
2.7 to 51 Volts  
300m Watts Power Dissipation

### SOT-23

### Features

- ✧ Dual zeners in common cathode configuration
- ✧ 300 mW power dissipation
- ✧ Ideally suited for automated insertion
- ✧  $\Delta V_z$  for both diodes in one case is  $\leq 5\%$
- ✧ Common anode style available see AZ series

### Mechanical Data

- ✧ Case: SOT-23, Molded plastic
- ✧ Terminals: Solderable per MIIIL-STD-202, Method 208
- ✧ Polarity: See diagram
- ✧ Marking: Marking Code (see table on Page 2)
- ✧ Mounting position: Any
- ✧ Weight: 0.008 grams (approx.)

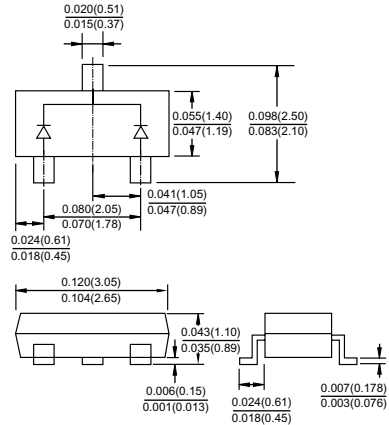

### Maximum Ratings and Electrical Characteristics

Rating at 25°C ambient temperature unless otherwise specified.

### Maximum Ratings

Type Number	Symbol	Value	Units
Power Dissipation (Note 1)	$P_d$	300	mW
Thermal Resistance Junction to Ambient Air (Note 1)	$R_{\theta JA}$	420	K/W
Operating and Storage Temperature Range	$T_J, T_{STG}$	-65 to + 150	°C

Notes: 1. Device on Fiberglass Substrate.

2. Tested with IZT Current pulses. Pulse width = 5ms.

ELECTRICAL CHARACTERISTICS (TA=25°C unless otherwise noted)

Device (Note 1)	Device Marking Code	Zener Voltage Range @ I <sub>ZT</sub> = 5.0mA V <sub>Z</sub> (Volts) (Notes 2)	Maximum Zener Impedance		Typical Temperature Coefficient	Min Reverse Voltage @ I <sub>R</sub> = 0.1uA V <sub>R</sub> (Volts)
			Z <sub>ZT</sub> @ I <sub>ZT</sub> = 5.0mA	Z <sub>ZK</sub> @ I <sub>ZK</sub> = 1.0mA		
			Ohms	Ohms	T <sub>c</sub> (%/°C)	
DZ23C2V7	V1	2.5-2.9	83	500	-0.065	-
DZ23C3V0	V2	2.8-3.2	95	500	-0.060	-
DZ23C3V3	V3	3.1-3.5	95	500	-0.055	-
DZ23C3V6	V4	3.4-3.8	95	500	-0.055	-
DZ23C3V9	V5	3.7-4.1	95	500	-0.050	-
DZ23C4V3	V6	4.0-4.6	95	500	-0.035	-
DZ23C4V7	V7	4.4-5.0	78	500	-0.015	-
DZ23C5V1	V8	4.8-5.4	60	480	+0.005	0.8
DZ23C5V6	V9	5.2-6.0	40	400	+0.020	1.0
DZ23C6V2	V10	5.8-6.6	10	200	+0.030	2.0
DZ23C6V8	V11	6.4-7.2	8.0	150	+0.045	3.0
DZ23C7V5	V12	7.0-7.9	7.0	50	+0.050	5.0
DZ23C8V2	V13	7.7-8.7	7.0	50	+0.055	6.0
DZ23C9V1	V14	8.5-9.6	10	50	+0.065	7.0
DZ23C10	V15	9.4-10.6	15	70	+0.065	7.5
DZ23C11	V16	10.4-11.6	20	70	+0.070	8.5
DZ23C12	V17	11.4-12.7	20	90	+0.075	9.0
DZ23C13	V18	12.4-14.1	25	110	+0.080	10.0
DZ23C15	V19	13.8-15.6	30	110	+0.080	11.0
DZ23C16	V20	15.30-17.1	40	170	+0.090	12.0
DZ23C18	V21	16.8-19.1	50	170	+0.090	14.0
DZ23C20	V22	18.8-21.2	50	220	+0.090	15.0
DZ23C22	V23	20.8-23.3	55	220	+0.090	17.0
DZ23C24	V24	22.8-25.6	80	220	+0.090	18.0
DZ23C27	V25	25.1-28.9	80	250	+0.090	20.0
DZ23C30	V26	28-32	80	250	+0.090	22.5
DZ23C33	V27	31-35	80	250	+0.090	25.0
DZ23C36	V28	34-39	90	250	+0.090	27.0
DZ23C39	V29	37-41	90	300	+0.110	29.0
DZ23C43	V30	40-46	100	700	+0.110	32.0
DZ23C47	V31	44-50	100	750	+0.110	35.0
DZ23C51	V32	48-54	100	750	+0.110	38.0

Notes: 1. Device on fiberglass substrate.

2. Tested with I<sub>ZT</sub> current pulses. Pulse width = 5.0ms.



LittleDiode supplies new, hard to find or obsolete electronic components and semiconductors all over the world.

With over two million different components listed you are sure to find the part you need.

Feel free to visit us today at our online store:

[LittleDiode.com](http://LittleDiode.com)

Looking forward to providing you with the best possible service.