

2SK682, 2SK683

SILICON N-CHANNEL MOS FET

高速度電力スイッチング

■ 特長

- オン抵抗が低い。
- スwitchングスピードが速い。
- 駆動電力が小さい。
- 2次降伏がない。
- スwitchングレギュレータ、DC-DCコンバータ、モータドライバなどに最適。

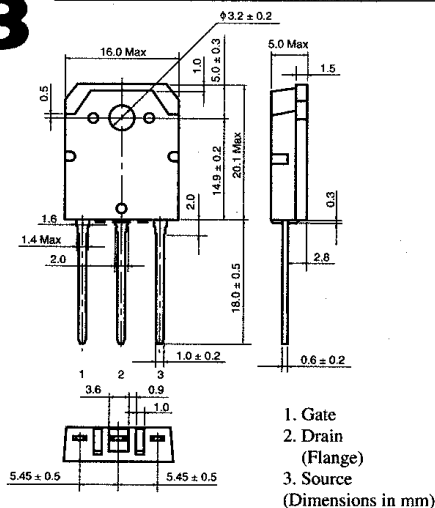
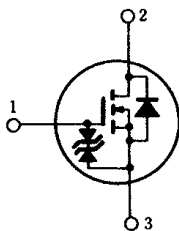

(TO-3P)

POWER VS. TEMPERATURE DERATING

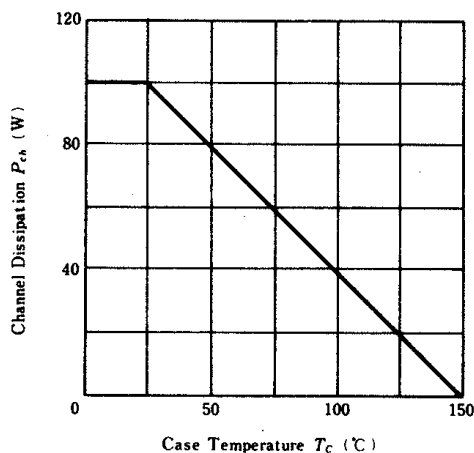

■ ABSOLUTE MAXIMUM RATINGS ($T_a=25^\circ\text{C}$)

Item	Symbol	2SK682	2SK683	Unit
Drain-Source Voltage	V_{DSS}	450	500	V
Gate-Source Voltage	V_{GSS}	±20		V
Drain Current	I_D	12		A
Drain Peak Current	$I_{D(pulse)}$ *	48		A
Body-Drain Diode Reverse Drain Current	I_{DR}	12		A
Channel Dissipation	P_{ch} **	100		W
Channel Temperature	T_{ch}	150		°C
Storage Temperature	T_{stg}	-55 ~ +150		°C

*PW ≤ 10μs, duty cycle ≤ 1%

**Value at $T_c=25^\circ\text{C}$

■ ELECTRICAL CHARACTERISTICS ($T_a=25^\circ\text{C}$)

Item	Symbol	Test Condition	min.	typ.	max.	Unit
Drain-Source Breakdown Voltage	2SK682	$I_D=10\text{mA}, V_{GS}=0$	450	—	—	V
	2SK683		500	—	—	
Gate-Source Breakdown Voltage	$V_{(BR)GSS}$	$I_G=\pm 100\mu\text{A}, V_{DS}=0$	±20	—	—	V
Gate-Source Leak Current	I_{GSS}	$V_{GS}=\pm 16\text{V}, V_{DS}=0$	—	—	±10	μA
Zero Gate Voltage Drain Current	2SK682	$V_{DS}=360\text{V}, V_{GS}=0$	—	—	250	μA
	2SK683		$V_{DS}=400\text{V}, V_{GS}=0$	—	—	
Gate-Source Cutoff Voltage	$V_{GS(off)}$	$I_D=1\text{mA}, V_{DS}=10\text{V}$	2.0	—	4.0	V
Static Drain-Source On State Resistance	2SK682	$I_D=6\text{A}, V_{GS}=10\text{V}^*$	—	0.4	0.55	Ω
	2SK683		—	0.45	0.60	
Forward Transfer Admittance	$ y_{fs} $	$I_D=6\text{A}, V_{DS}=10\text{V}^*$	6	10	—	S
Input Capacitance	C_{iss}	$V_{DS}=10\text{V}, V_{GS}=0, f=1\text{MHz}$	—	2050	—	pF
Output Capacitance	C_{oss}		—	720	—	pF
Reverse Transfer Capacitance	C_{rss}		—	80	—	pF
Turn-on Delay Time	$t_{d(on)}$		—	25	—	ns
Rise Time	t_r	$I_D=6\text{A}, V_{GS}=10\text{V}, R_L=5\Omega$	—	85	—	ns
Turn-off Delay Time	$t_{d(off)}$		—	145	—	ns
Fall Time	t_f		—	85	—	ns
Body-Drain Diode Forward Voltage	V_{DF}	$I_F=12\text{A}, V_{GS}=0$	—	1.0	—	V
Body-Drain Diode Reverse Recovery Time	t_{rr}	$I_F=12\text{A}, V_{GS}=0, di_F/dt=100\text{A}/\mu\text{s}$	—	120	—	ns

*Pulse Test