

DATA SHEET

BFQ136

NPN 4 GHz wideband transistor

Product specification
File under Discrete Semiconductors, SC14

September 1995

NPN 4 GHz wideband transistor

BFQ136

DESCRIPTION

NPN transistor in a four-lead dual-emitter SOT122A envelope with a ceramic cap. All leads are isolated from the stud. Diffused emitter-ballasting resistors and the application of gold sandwich metallization ensure an optimum temperature profile and excellent reliability properties. It features extremely high output voltage capabilities.

It is primarily intended for final stages in UHF amplifiers.

PINNING

PIN	DESCRIPTION
1	collector
2	emitter
3	base
4	emitter

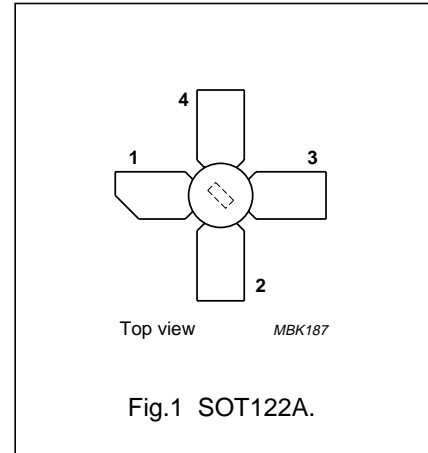

QUICK REFERENCE DATA

SYMBOL	PARAMETER	CONDITIONS	TYP.	MAX.	UNIT
V_{CEO}	collector-emitter voltage	open base	–	18	V
I_C	DC collector current		–	600	mA
P_{tot}	total power dissipation	up to $T_c = 100\text{ °C}$	–	9	W
f_T	transition frequency	$I_C = 500\text{ mA}; V_{CE} = 15\text{ V}; f = 500\text{ MHz}; T_j = 25\text{ °C}$	4.0	–	GHz
G_{UM}	maximum unilateral power gain	$I_C = 500\text{ mA}; V_{CE} = 15\text{ V}; f = 800\text{ MHz}; T_{amb} = 25\text{ °C}$	12.5	–	dB
V_o	output voltage	$I_C = 500\text{ mA}; V_{CE} = 15\text{ V}; d_{im} = -60\text{ dB}; R_L = 75\text{ }\Omega; f_{(p+q-r)} = 793.25\text{ MHz}; T_{amb} = 25\text{ °C}$	2.5	–	V

WARNING

Product and environmental safety - toxic materials

This product contains beryllium oxide. The product is entirely safe provided that the BeO disc is not damaged. All persons who handle, use or dispose of this product should be aware of its nature and of the necessary safety precautions. After use, dispose of as chemical or special waste according to the regulations applying at the location of the user. It must never be thrown out with the general or domestic waste.

NPN 4 GHz wideband transistor

BFQ136

LIMITING VALUES

In accordance with the Absolute Maximum System (IEC 134).

SYMBOL	PARAMETER	CONDITIONS	MIN.	MAX.	UNIT
V _{CBO}	collector-base voltage	open emitter	–	25	V
V _{CEO}	collector-emitter voltage	open base	–	18	V
V _{EBO}	emitter-base voltage	open collector	–	2	V
I _C	DC collector current		–	600	mA
P _{tot}	total power dissipation	up to T _C = 100 °C	–	9	W
T _{stg}	storage temperature		–65	150	°C
T _j	junction temperature		–	200	°C

THERMAL RESISTANCE

SYMBOL	PARAMETER	THERMAL RESISTANCE
R _{th j-c}	thermal resistance from junction to case	11 K/W

CHARACTERISTICS

T_j = 25 °C unless otherwise specified.

SYMBOL	PARAMETER	CONDITIONS	MIN.	TYP.	MAX.	UNIT
I _{CBO}	collector cut-off current	I _E = 0; V _{CB} = 15 V	–	–	75	μA
h _{FE}	DC current gain	I _C = 500 mA; V _{CE} = 15 V	25	75	–	
C _c	collector capacitance	I _E = i _e = 0; V _{CB} = 15 V; f = 1 MHz	–	7.0	–	pF
C _e	emitter capacitance	I _C = i _c = 0; V _{EB} = 0.5 V; f = 1 MHz	–	40	–	pF
C _{re}	feedback capacitance	I _C = 0; V _{CE} = 15 V; f = 1 MHz	–	4.0	–	pF
C _{cs}	collector-stud capacitance	note 1	–	0.8	–	pF
f _T	transition frequency	I _C = 500 mA; V _{CE} = 15 V; f = 500 MHz	–	4.0	–	GHz
G _{UM}	maximum unilateral power gain (note 2)	I _C = 500 mA; V _{CE} = 15 V; f = 800 MHz; T _{amb} = 25 °C	–	12.5	–	dB
V _o	output voltage (see Fig.2)	note 3	–	2.5	–	V

Notes

1. Measured with emitter and base grounded.
2. G_{UM} is the maximum unilateral power gain, assuming S₁₂ is zero and

$$G_{UM} = 10 \log \left(\frac{|S_{21}|^2}{(1 - |S_{11}|^2)(1 - |S_{22}|^2)} \right) \text{ dB.}$$

3. d_{im} = –60 dB; I_C = 500 mA; V_{CE} = 15 V; R_L = 75 Ω; T_{amb} = 25 °C;
V_p = V_o at d_{im} = –60 dB; f_p = 795.25 MHz;
V_q = V_o –6 dB; f_q = 803.25 MHz;
V_r = V_o –6 dB; f_r = 805.25 MHz;
measured at f_(p+q-r) = 793.25 MHz.

NPN 4 GHz wideband transistor

BFQ136

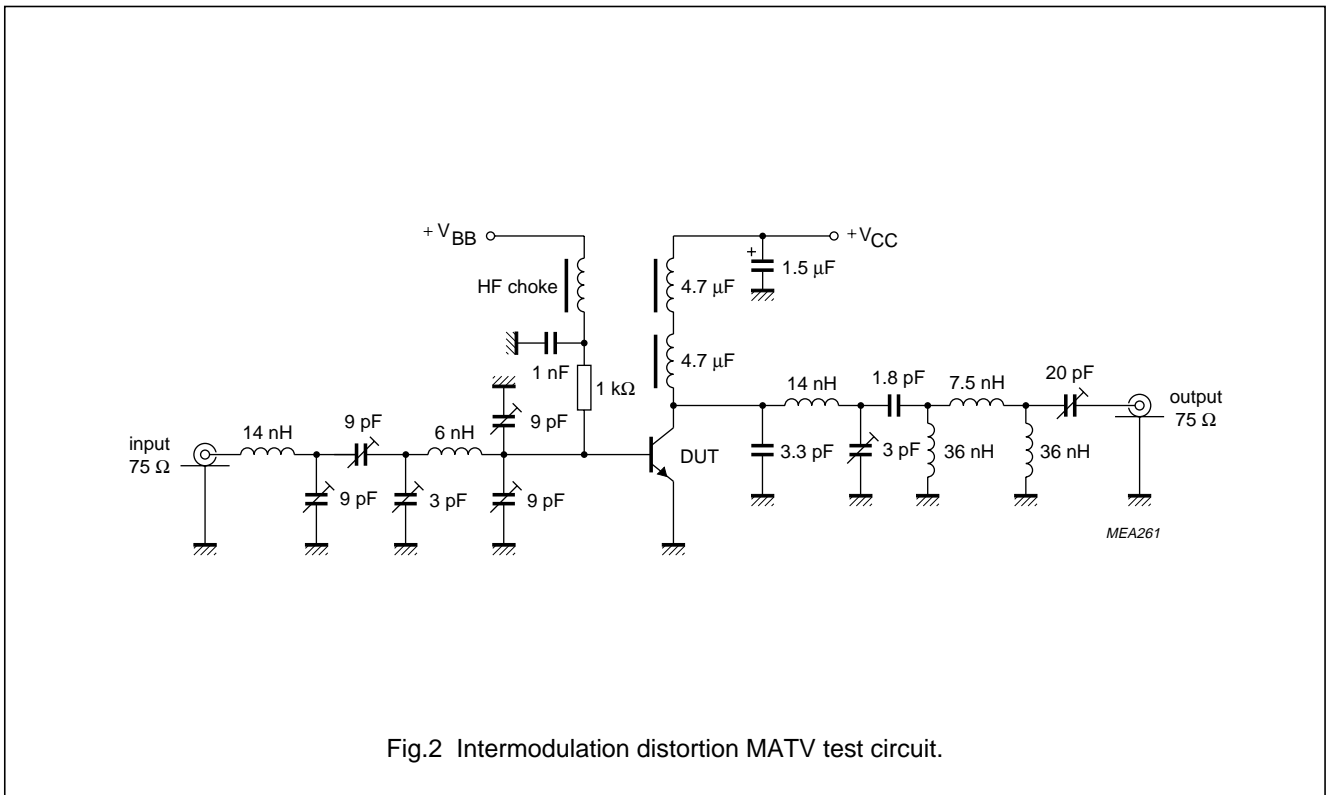

Fig.2 Intermodulation distortion MATV test circuit.

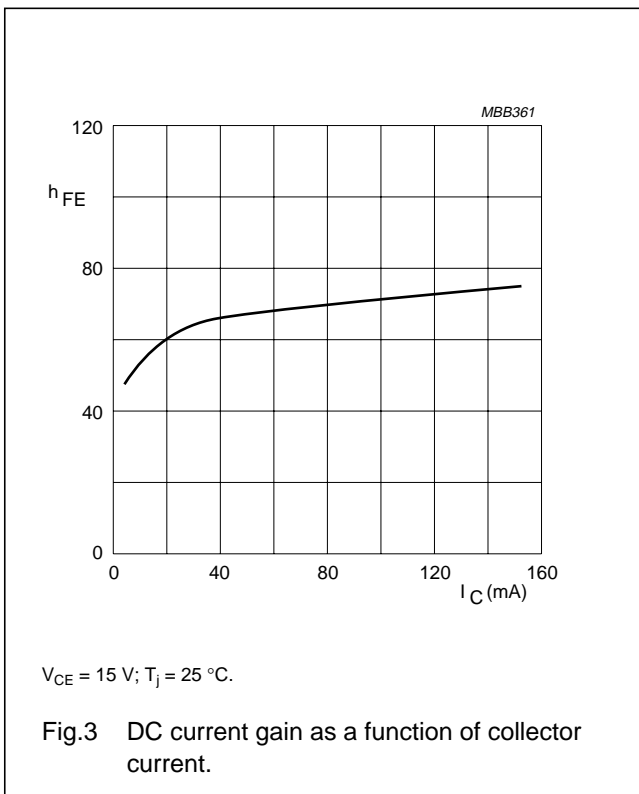

Fig.3 DC current gain as a function of collector current.

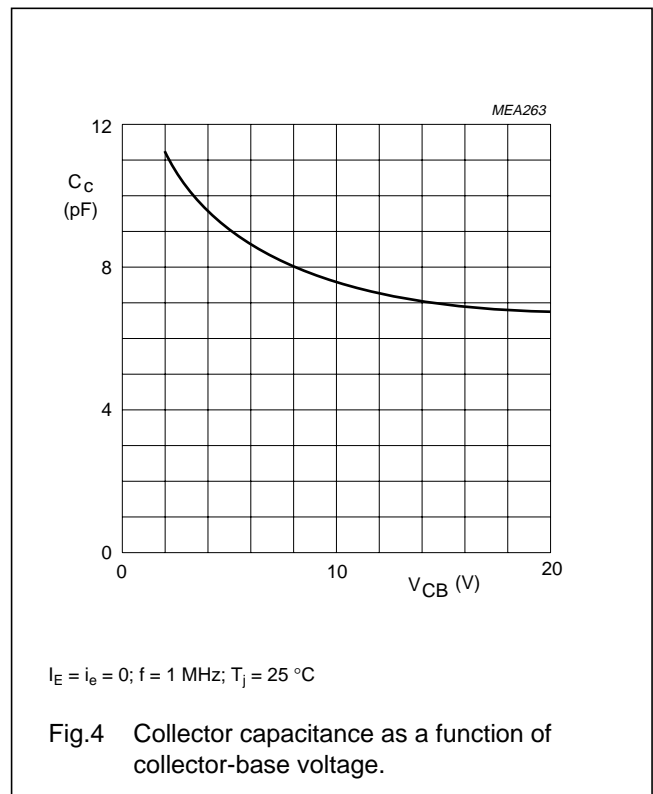
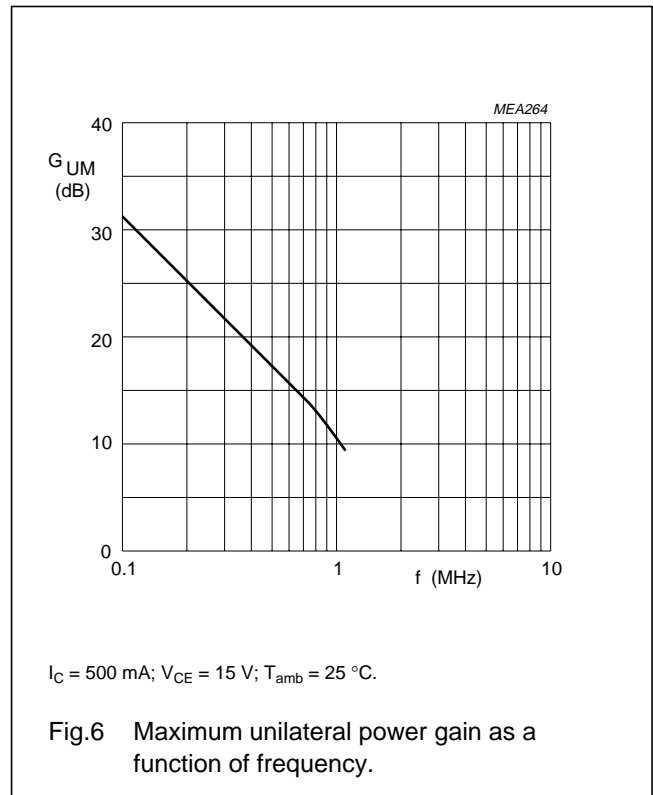
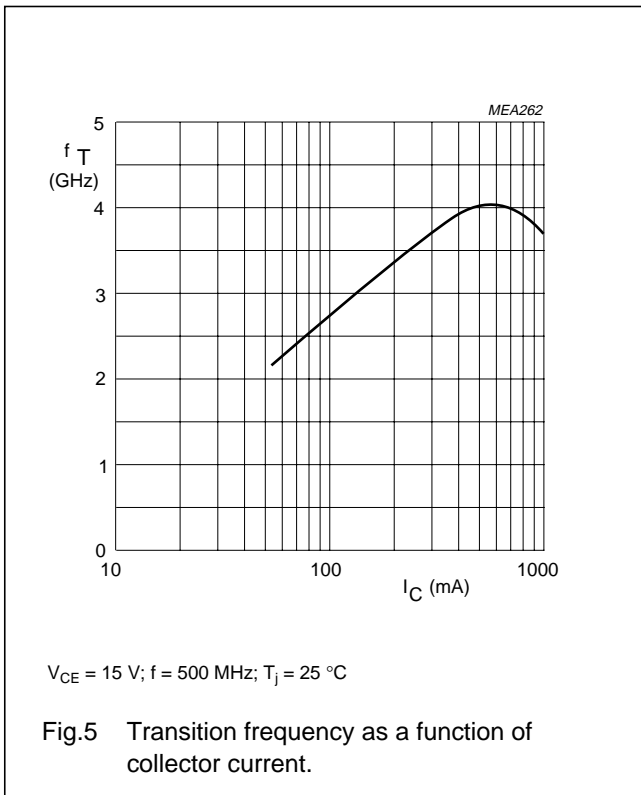

Fig.4 Collector capacitance as a function of collector-base voltage.

NPN 4 GHz wideband transistor

BFQ136



NPN 4 GHz wideband transistor

BFQ136

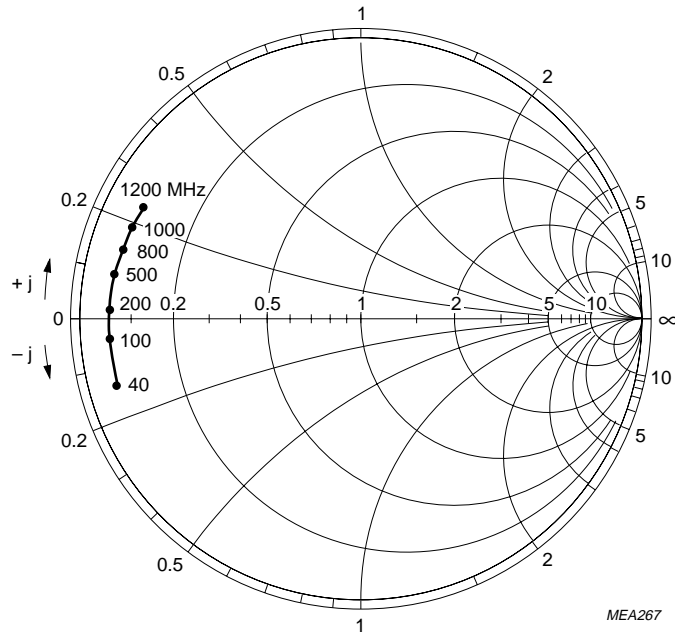

$I_C = 500 \text{ mA}$; $V_{CE} = 15 \text{ V}$; $T_{amb} = 25 \text{ }^\circ\text{C}$.
 $Z_0 = 50 \text{ } \Omega$.

MEA267

Fig.7 Common emitter input reflection coefficient (S_{11}).

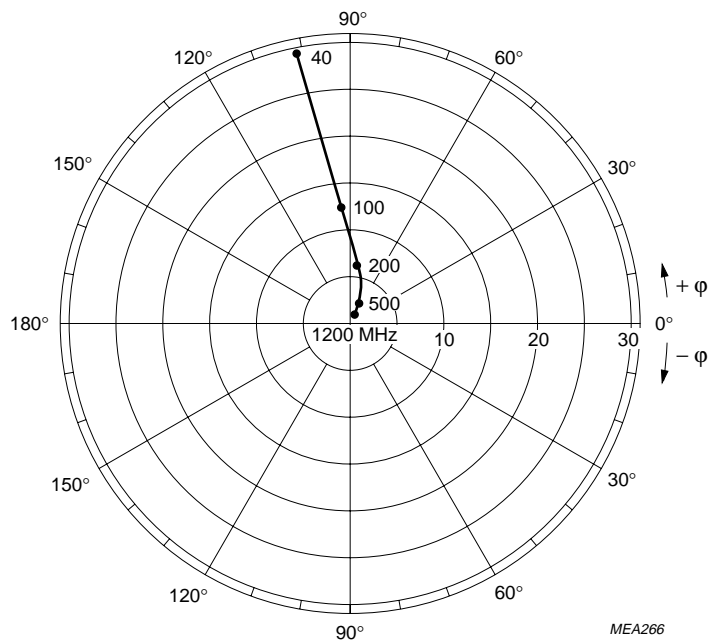

$I_C = 500 \text{ mA}$; $V_{CE} = 15 \text{ V}$; $T_{amb} = 25 \text{ }^\circ\text{C}$.

MEA266

Fig.8 Common emitter forward transmission coefficient (S_{21}).

NPN 4 GHz wideband transistor

BFQ136

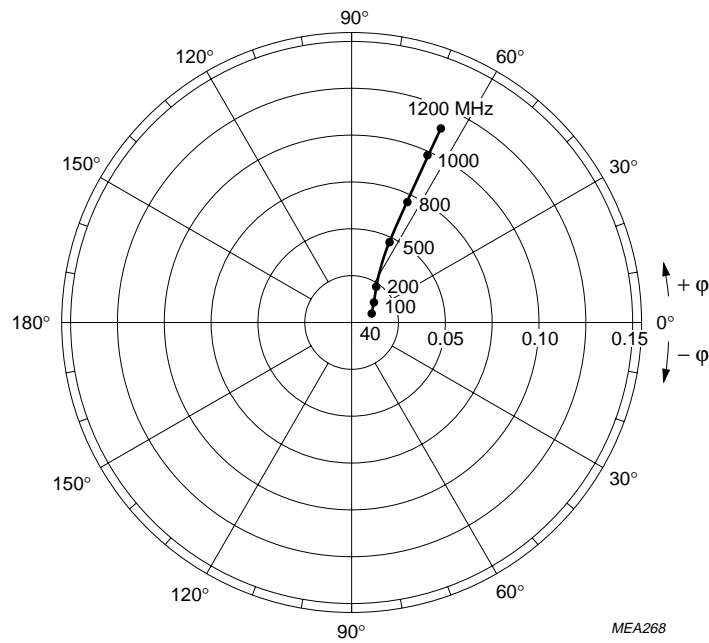

$I_C = 500 \text{ mA}$; $V_{CE} = 15 \text{ V}$; $T_{amb} = 25 \text{ }^\circ\text{C}$.

Fig.9 Common emitter reverse transmission coefficient (S_{12}).

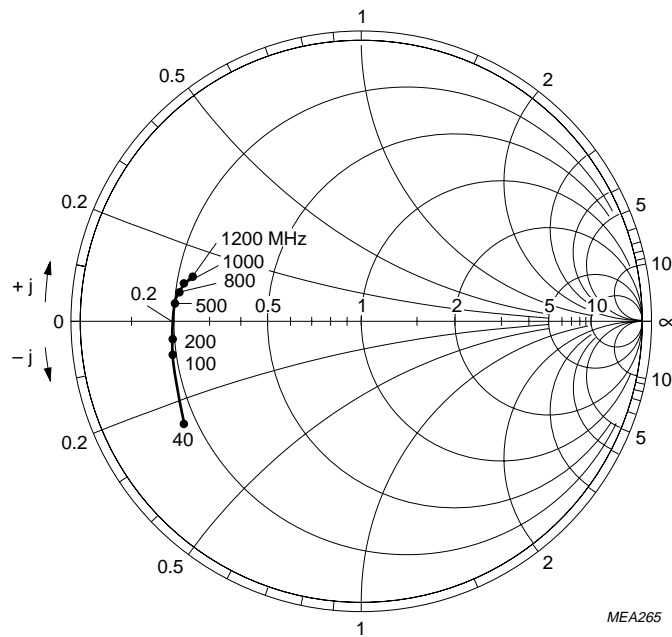

$I_C = 500 \text{ mA}$; $V_{CE} = 15 \text{ V}$; $T_{amb} = 25 \text{ }^\circ\text{C}$.
 $Z_0 = 50 \text{ } \Omega$.

Fig.10 Common emitter output reflection coefficient (S_{22}).

NPN 4 GHz wideband transistor

BFQ136

PACKAGE OUTLINE

Studded ceramic package; 4 leads

SOT122A

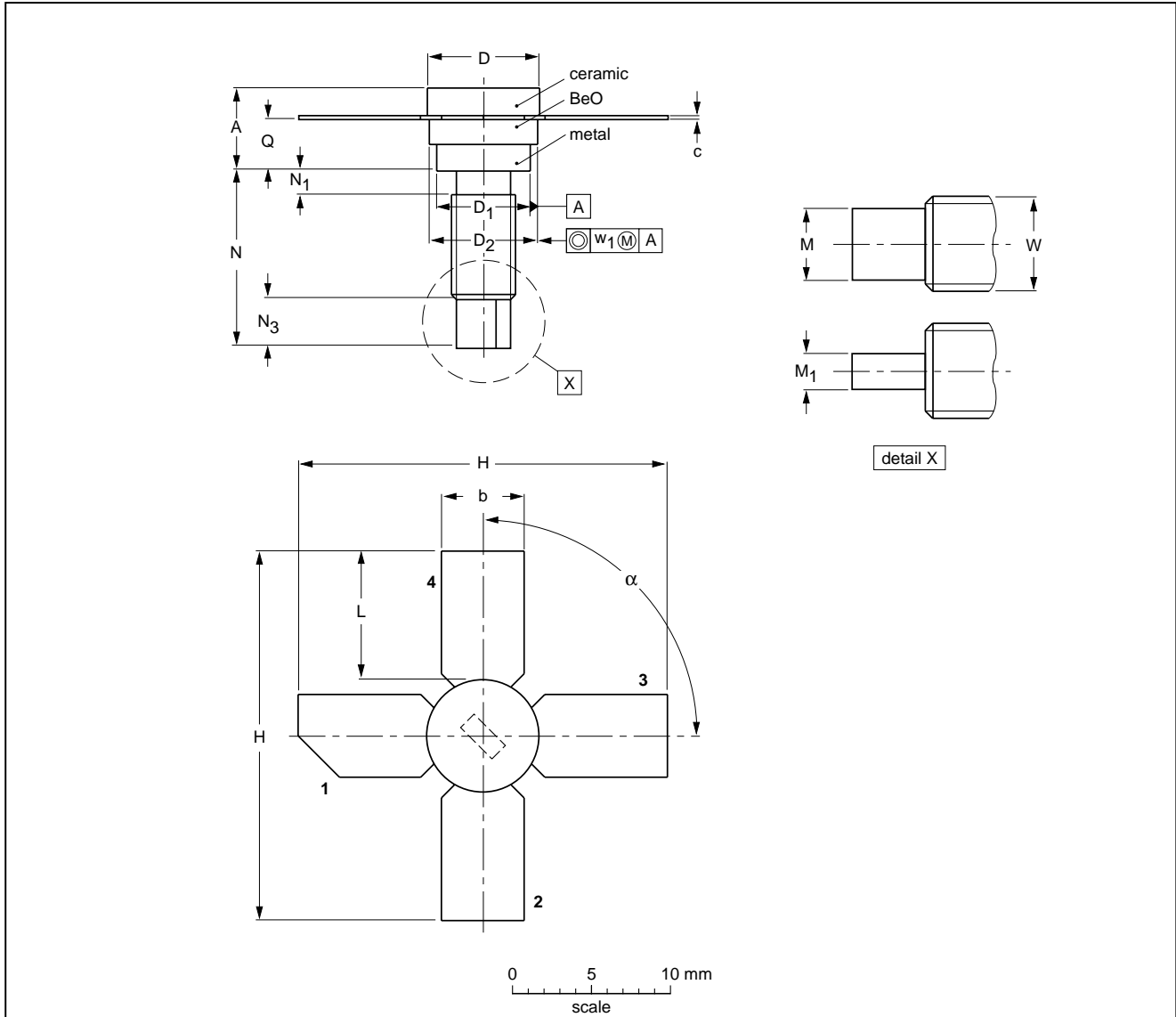

DIMENSIONS (millimetre dimensions are derived from the original inch dimensions)

UNIT	A	b	c	D	D ₁	D ₂	H	L	M ₁	M	N	N ₁ max.	N ₃	Q	W	w ₁	α
mm	5.97 4.74	5.85 5.58	0.18 0.14	7.50 7.23	6.48 6.22	7.24 6.93	27.56 25.78	9.91 9.14	3.18 2.66	1.66 1.39	11.82 11.04	1.02	3.86 2.92	3.38 2.74	8-32 UNC	0.381	90°

OUTLINE VERSION	REFERENCES				EUROPEAN PROJECTION	ISSUE DATE
	IEC	JEDEC	EIAJ			
SOT122A						97-04-18

NPN 4 GHz wideband transistor

BFQ136

DEFINITIONS

Data Sheet Status	
Objective specification	This data sheet contains target or goal specifications for product development.
Preliminary specification	This data sheet contains preliminary data; supplementary data may be published later.
Product specification	This data sheet contains final product specifications.
Limiting values	
Limiting values given are in accordance with the Absolute Maximum Rating System (IEC 134). Stress above one or more of the limiting values may cause permanent damage to the device. These are stress ratings only and operation of the device at these or at any other conditions above those given in the Characteristics sections of the specification is not implied. Exposure to limiting values for extended periods may affect device reliability.	
Application information	
Where application information is given, it is advisory and does not form part of the specification.	

LIFE SUPPORT APPLICATIONS

These products are not designed for use in life support appliances, devices, or systems where malfunction of these products can reasonably be expected to result in personal injury. Philips customers using or selling these products for use in such applications do so at their own risk and agree to fully indemnify Philips for any damages resulting from such improper use or sale.



LittleDiode supplies new, hard to find or obsolete electronic components and semiconductors all over the world.

With over two million different components listed you are sure to find the part you need.

Feel free to visit us today at our online store:

LittleDiode.com

Looking forward to providing you with the best possible service.