

DATA SHEET

BLW60C VHF power transistor

Product specification

March 1993

VHF power transistor

BLW60C

DESCRIPTION

N-P-N silicon planar epitaxial transistor intended for use in class-A, B and C operated mobile, industrial and military transmitters with a nominal supply voltage of 12,5 V. The transistor is resistance stabilized and is guaranteed to withstand severe load mismatch conditions with a supply over-voltage to 16,5 V.

Matched h_{FE} groups are available on request.

It has a 3/8" capstan envelope with a ceramic cap. All leads are isolated from the stud.

QUICK REFERENCE DATA

R.F. performance up to $T_h = 25\text{ }^\circ\text{C}$

MODE OF OPERATION	V_{CC} V	f MHz	P_L W	G_L dB	η %	\bar{Z}_i Ω	\bar{Z}_L Ω	d_3 dB
c.w. (class-B)	12,5	175	45	> 5,0	> 75	1,2 + j1,4	2,6 - j1,2	-
s.s.b. (class-AB)	12,5	1,6-28	3-30 (P.E.P.)	typ. 19,5	typ. 35	-	-	typ. -33

PIN CONFIGURATION

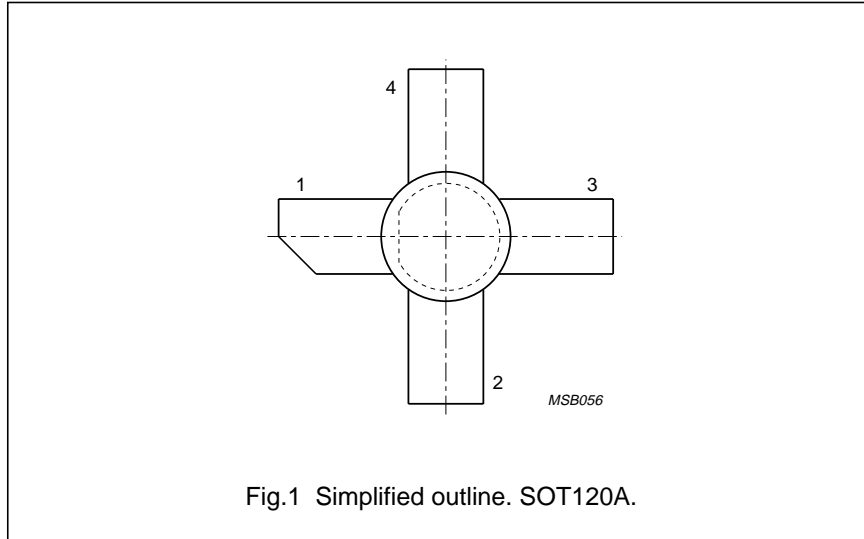

PINNING - SOT120A.

PIN	DESCRIPTION
1	collector
2	emitter
3	base
4	emitter

PRODUCT SAFETY This device incorporates beryllium oxide, the dust of which is toxic. The device is entirely safe provided that the BeO disc is not damaged.

VHF power transistor

BLW60C

RATINGS

Limiting values in accordance with the Absolute Maximum System (IEC 134)

Collector-emitter voltage ($V_{BE} = 0$)

peak value

V_{CESM} max. 36 V

Collector-emitter voltage (open base)

V_{CEO} max. 16 V

Emitter-base voltage (open collector)

V_{EBO} max. 4 V

Collector current (average)

$I_{C(AV)}$ max. 9 A

Collector current (peak value); $f > 1$ MHz

I_{CM} max. 22 A

R.F. power dissipation ($f > 1$ MHz); $T_{mb} = 25$ °C

P_{rf} max. 100 W

Storage temperature

T_{stg} -65 to + 150 °C

Operating junction temperature

T_j max. 200 °C

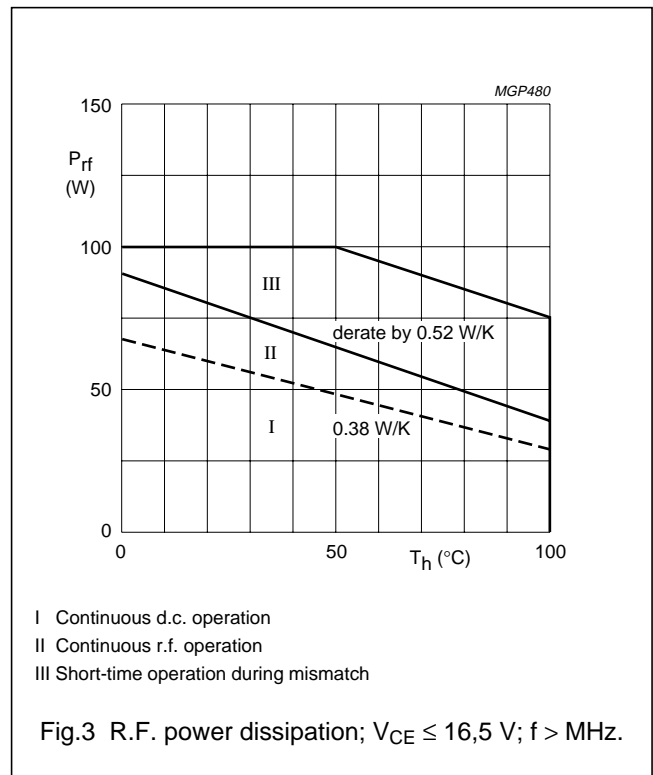
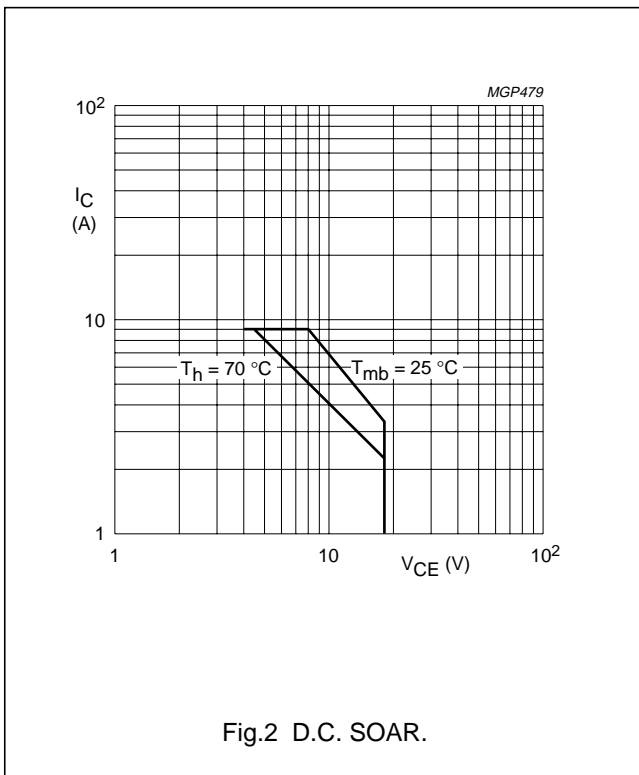

THERMAL RESISTANCE

(dissipation = 40 W; $T_{mb} = 88$ °C, i.e. $T_h = 70$ °C)

From junction to mounting base (d.c. dissipation)

$R_{th\ j-mb(dc)}$ = 2,8 K/W

From junction to mounting base (r.f. dissipation)

$R_{th\ j-mb(rf)}$ = 2,05 K/W

From mounting base to heatsink

$R_{th\ mb-h}$ = 0,45 K/W

VHF power transistor

BLW60C

CHARACTERISTICS $T_j = 25\text{ }^\circ\text{C}$ **Breakdown voltage**

Collector-emitter voltage

 $V_{BE} = 0; I_C = 50\text{ mA}$ $V_{(BR)CES} > 36\text{ V}$

Collector-emitter voltage

open base; $I_C = 100\text{ mA}$ $V_{(BR)CEO} > 16\text{ V}$

Emitter-base voltage

open collector; $I_E = 25\text{ mA}$ $V_{(BR)EBO} > 4\text{ V}$ **Collector cut-off current** $V_{BE} = 0; V_{CE} = 15\text{ V}$ $I_{CES} < 25\text{ mA}$ **Transient energy** $L = 25\text{ mH}; f = 50\text{ Hz}$

open base

 $E > 8\text{ ms}$ $-V_{BE} = 1,5\text{ V}; R_{BE} = 33\text{ }\Omega$ $E > 8\text{ ms}$ **D.C. current gain** ⁽¹⁾ $I_C = 4\text{ A}; V_{CE} = 5\text{ V}$ h_{FE} typ 50
10 to 80**D.C. current gain ratio of matched devices** ⁽¹⁾ $I_C = 4\text{ A}; V_{CE} = 5\text{ V}$ $h_{FE1}/h_{FE2} < 1,2$ **Collector-emitter saturation voltage** ⁽¹⁾ $I_C = 12,5\text{ A}; I_B = 2,5\text{ A}$ V_{CEsat} typ 1,5 V**Transition frequency at $f = 100\text{ MHz}$** ⁽¹⁾ $I_C = 4\text{ A}; V_{CE} = 12,5\text{ V}$ f_T typ 650 MHz $I_C = 12,5\text{ A}; V_{CE} = 12,5\text{ V}$ f_T typ 600 MHz**Collector capacitance at $f = 1\text{ MHz}$** $I_E = I_e = 0; V_{CB} = 15\text{ V}$ C_c typ 120 pF
< 160 pF**Feedback capacitance at $f = 1\text{ MHz}$** $I_C = 200\text{ mA}; V_{CE} = 15\text{ V}$ C_{re} typ 80 pF**Collector-stud capacitance** C_{cs} typ 2 pF**Note**1. Measured under pulse conditions: $t_p \leq 200\text{ }\mu\text{s}$; $\delta \leq 0,02$.

VHF power transistor

BLW60C

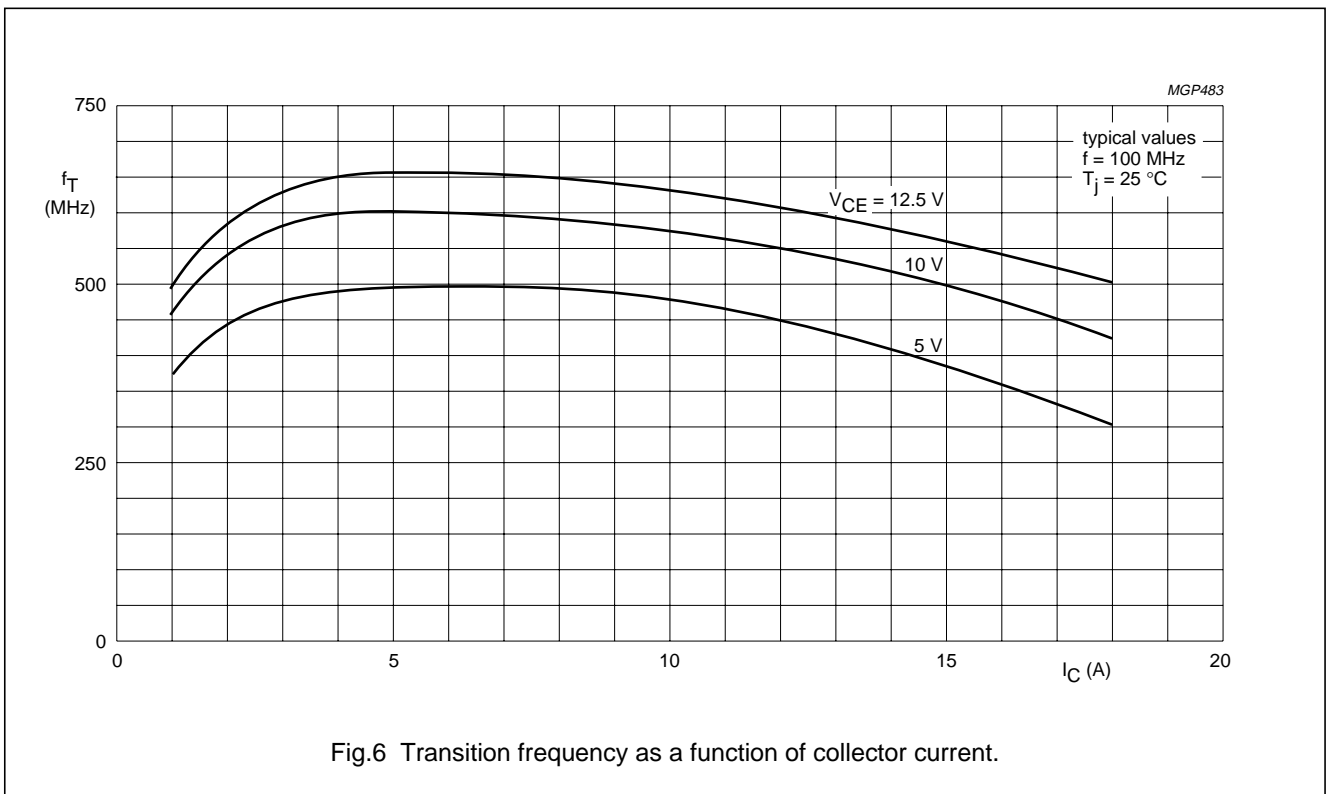
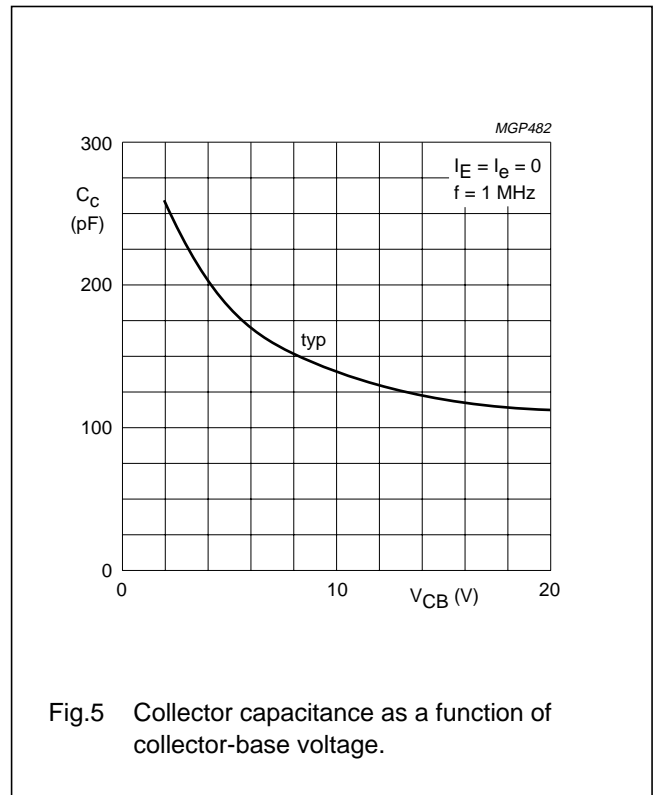
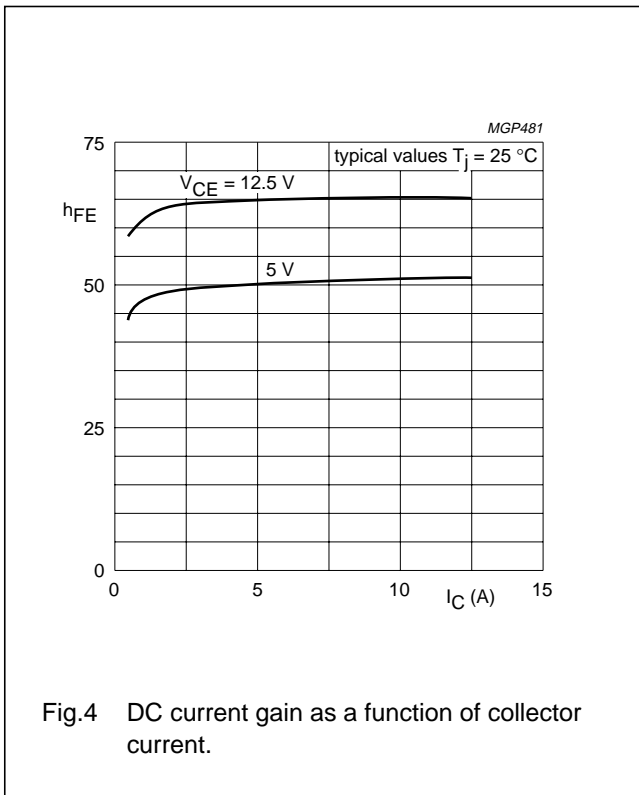

VHF power transistor

BLW60C

APPLICATION INFORMATION

R.F. performance in c.w. operation (unneutralized common-emitter class-B circuit); $T_h = 25\text{ }^\circ\text{C}$

f (MHz)	V _{CC} (V)	P _L (W)	P _S (W)	G _p (dB)	I _C (A)	η (%)	\bar{z}_i (Ω)	\bar{z}_L (Ω)
175	12,5	45	< 14,2	> 5,0	< 4,8	> 75	1,2 + j1,4	2,6 - j1,2
175	13,5	45	–	typ. 6,0	–	typ. 75	–	–

Test circuit for 175 MHz

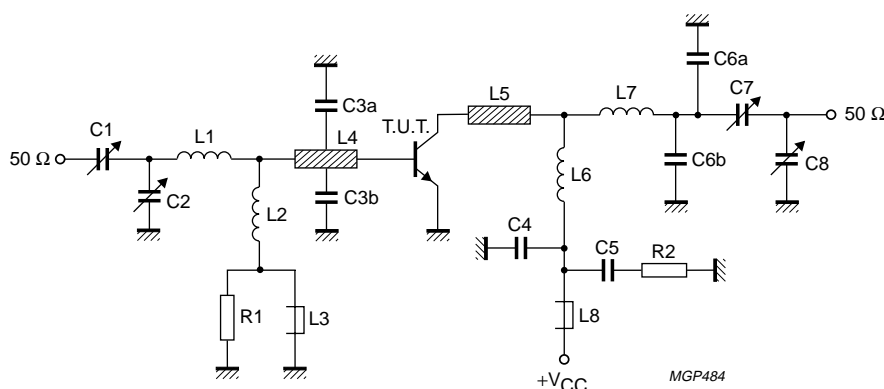

Fig.7 Class-B test circuit at f = 175 MHz.

List of components:

C1 = 2,5 to 20 pF film dielectric trimmer (cat. no. 2222 809 07004)

C2 = C8 = 4 to 40 pF film dielectric trimmer (cat. no. 2222 809 07008)

C3a = C3b = 47 pF ceramic capacitor (500 V)

C4 = 120 pF ceramic capacitor

C5 = 100 nF polyester capacitor

C6a = C6b = 8,2 pF ceramic capacitor (500 V)

C7 = 5 to 60 pF film dielectric trimmer (cat. no. 2222 809 07011)

L1 = 1 turn Cu wire (1,6 mm); int. dia. 9,0 mm; leads 2 × 5 mm

L2 = 100 nH; 7 turns closely wound enamelled Cu wire (0,5 mm); int. dia. 3 mm; leads 2 × 5 mm

L3 = L8 = Ferroxcube wide-band h.f. choke, grade 3B (cat. no. 4312 020 36640)

L4 = L5 = strip (12 mm × 6 mm); taps for C3a and C3b at 5 mm from transistor

L6 = 2 turns enamelled Cu wire (1,6 mm); int. dia. 5,0 mm; length 6,0 mm; leads 2 × 5 mm

L7 = 2 turns enamelled Cu wire (1,6 mm); int. dia. 4,5 mm; length 6,0 mm; leads 2 × 5 mm

L4 and L5 are strips on a double Cu-clad printed-circuit board with epoxy fibre-glass dielectric, thickness 1/16".

R1 = 10 Ω (±10%) carbon resistor

R2 = 4,7 Ω (±5%) carbon resistor

Component layout and printed-circuit board for 175 MHz test circuit: Fig.8.

VHF power transistor

BLW60C

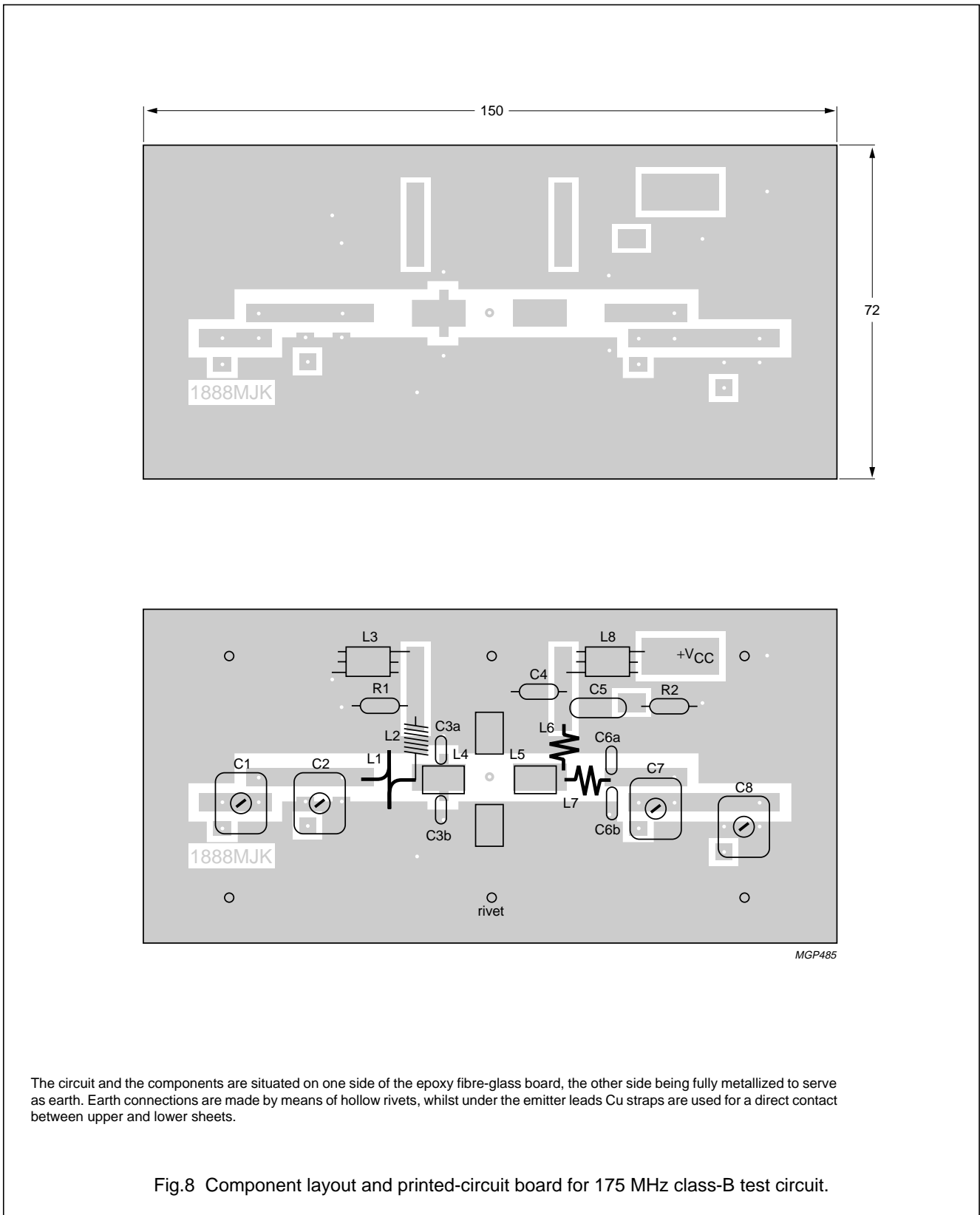

The circuit and the components are situated on one side of the epoxy fibre-glass board, the other side being fully metallized to serve as earth. Earth connections are made by means of hollow rivets, whilst under the emitter leads Cu straps are used for a direct contact between upper and lower sheets.

Fig.8 Component layout and printed-circuit board for 175 MHz class-B test circuit.

VHF power transistor

BLW60C

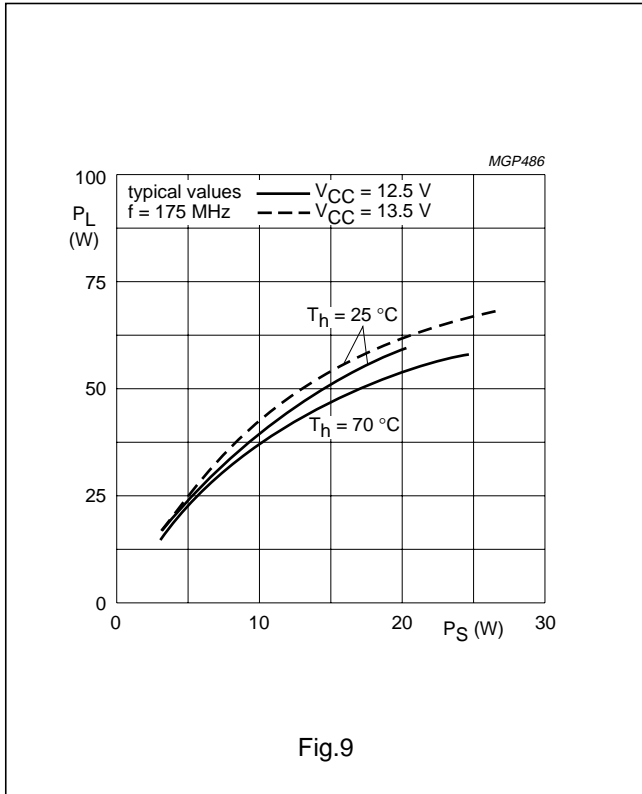

Fig.9

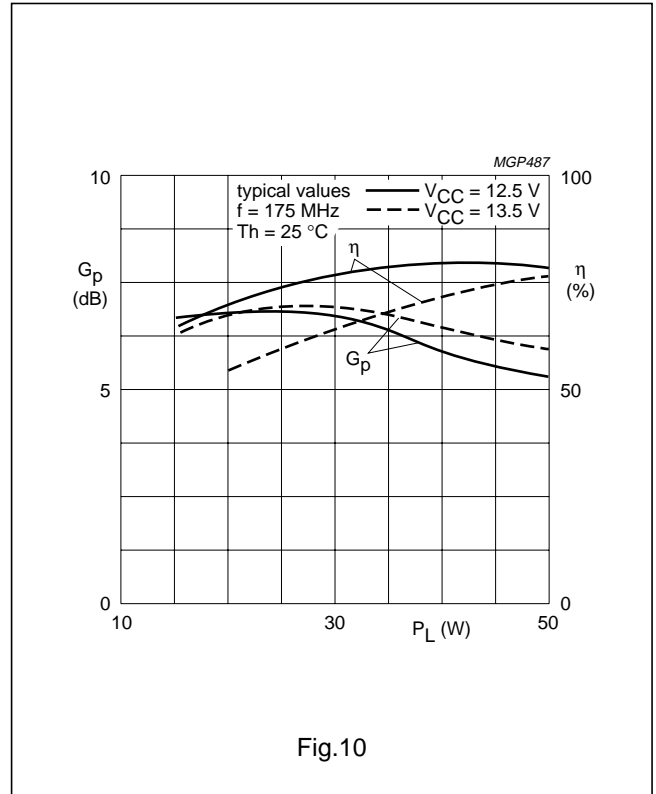

Fig.10

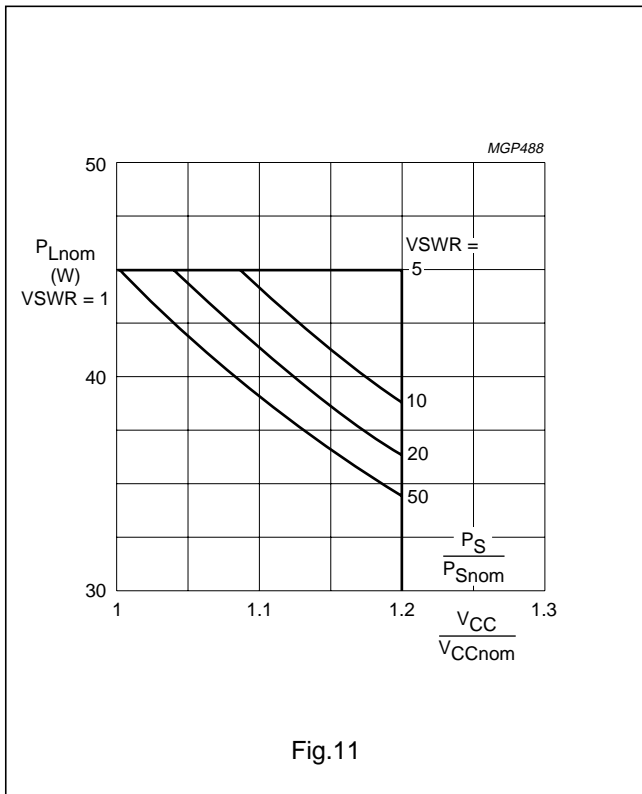

Fig.11

Conditions for R.F. SOAR

f = 175 MHz
 Th = 70 °C
 R_{th mb-h} = 0,45 K/W
 V_{CCnom} = 12,5 V or 13,5 V
 P_S = P_{Snom} at V_{CCnom} and VSWR = 1
 measured in circuit of Fig.7.

The transistor has been developed for use with unstabilized supply voltages. As the output power and drive power increase with the supply voltage, the nominal output power must be derated in accordance with the graph for safe operation at supply voltages other than the nominal. The graph shows the permissible output power under nominal conditions (VSWR = 1), as a function of the expected supply over-voltage ratio with VSWR as parameter.

The graph applies to the situation in which the drive (P_S/P_{Snom}) increases linearly with supply over-voltage ratio.

VHF power transistor

BLW60C

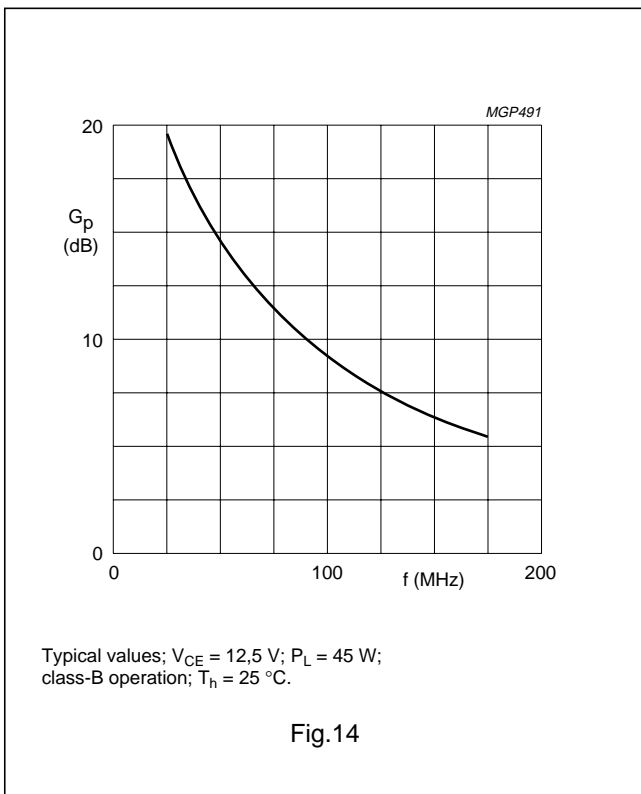
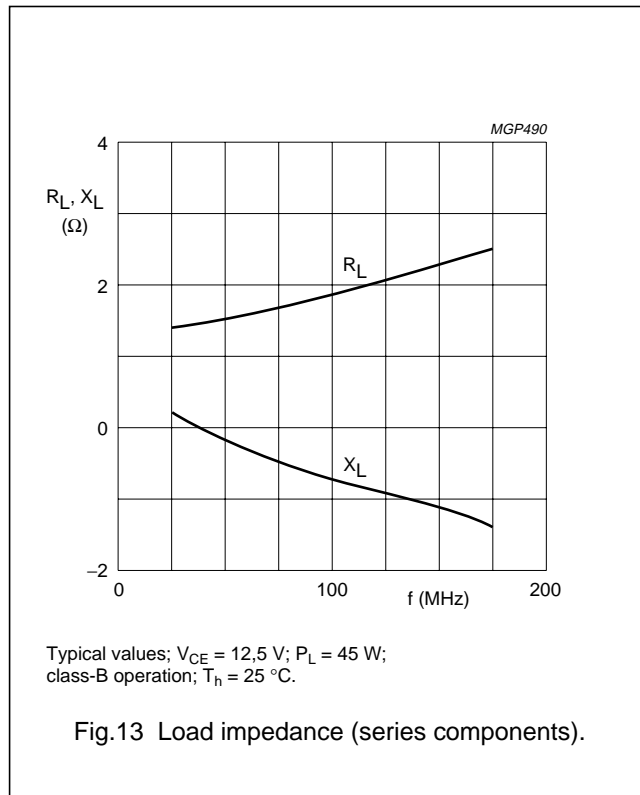
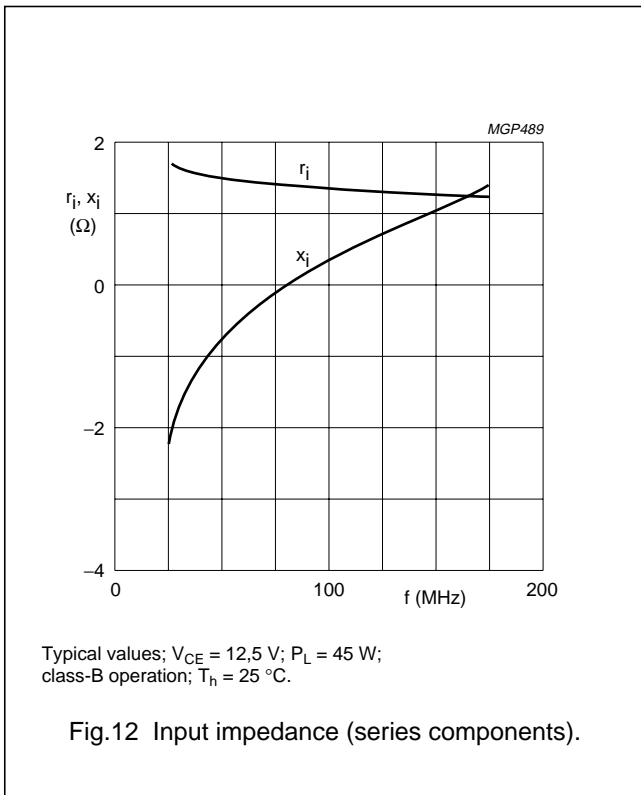

VHF power transistor

BLW60C

R.F. performance in s.s.b. class-AB operation

$V_{CE} = 12,5 \text{ V}$; T_h up to $25 \text{ }^\circ\text{C}$; $R_{th\text{ mb-h}} \leq 0,45 \text{ K/W}$

$f_1 = 28,000 \text{ MHz}$; $f_2 = 28,001 \text{ MHz}$

OUTPUT POWER W	G_p dB	η_{dt} %	d_3 dB ⁽¹⁾	d_5 dB ⁽¹⁾	$I_{C(zs)}$ mA
3 to 30 (P.E.P.)	typ 19,5	typ 35	typ -33	typ -36	25

Note

1. Stated intermodulation distortion figures are referred to the according level of either of the equal amplified tones. Relative to the according peak envelope powers these figures should be increased by 6 dB.

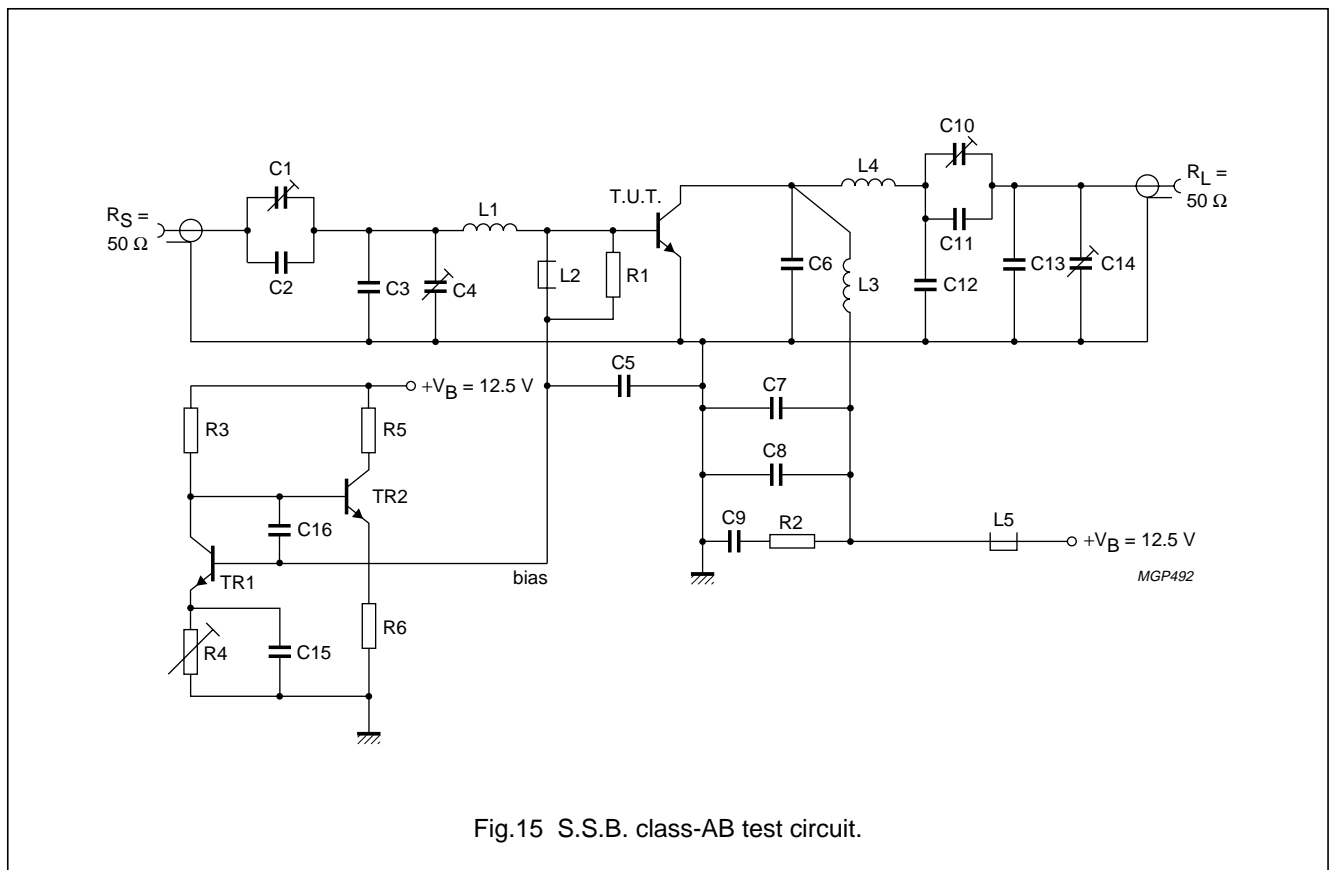

Fig.15 S.S.B. class-AB test circuit.

VHF power transistor

BLW60C

List of components:

TR1 = TR2 = BD137

C1 = 100 pF air dielectric trimmer (single insulated rotor type)

C2 = 27 pF ceramic capacitor

C3 = 180 pF ceramic capacitor

C4 = 100 pF air dielectric trimmer (single non-insulated rotor type)

C5 = C7 = 3,9 nF polyester capacitor

C6 = 2 × 270 pF polystyrene capacitors in parallel

C8 = C15 = C16 = 100 nF polyester capacitor

C9 = 2,2 µF moulded metallized polyester capacitor

C10 = 2 × 385 pF film dielectric trimmer

C11 = 68 pF ceramic capacitor

C12 = 2 × 82 pF ceramic capacitors in parallel

C13 = 47 pF ceramic capacitor

C14 = 385 pF film dielectric trimmer

L1 = 88 nH; 3 turns Cu wire (1,0 mm); int. dia. 9 mm; length 6,1 mm; leads 2 × 5 mm

L2 = L5 = Ferroxcube choke coil (cat. no. 4312 020 36640)

L3 = 68 nH; 3 turns enamelled Cu wire (1,6 mm); int. dia. 8 mm; length 8,3 mm; leads 2 × 5 mm

L4 = 96 nH; 3 turns enamelled Cu wire (1,6 mm); int. dia. 10 mm; length 7,6 mm; leads 2 × 5 mm

R1 = 27 Ω (±5%) carbon resistor

R2 = 4,7 Ω (±5%) carbon resistor

R3 = 1,5 kΩ (±5%) carbon resistor

R4 = 10 Ω wirewound potentiometer (3 W)

R5 = 47 Ω wirewound resistor (5,5 W)

R6 = 150 Ω (±5%) carbon resistor

Measuring conditions for Figs 16 and 17: $V_{CC} = 12,5 \text{ V}$ $f_1 = 28,000 \text{ MHz}$ $f_2 = 28,001 \text{ MHz}$ $T_h = 25 \text{ °C}$ $R_{th\ mb-h} \leq 0,45 \text{ ° K/W}$ $I_{C(ZS)} = 25 \text{ mA}$

typical values

Measuring conditions for Figs 18 and 19: $V_{CC} = 13,5 \text{ V}$ $f_1 = 28,000 \text{ MHz}$ $f_2 = 28,001 \text{ MHz}$ $T_h = 25 \text{ °C}$ $R_{th\ mb-h} \leq 0,45 \text{ ° K/W}$ $I_{C(ZS)} = 25 \text{ mA}$

typical values

VHF power transistor

BLW60C

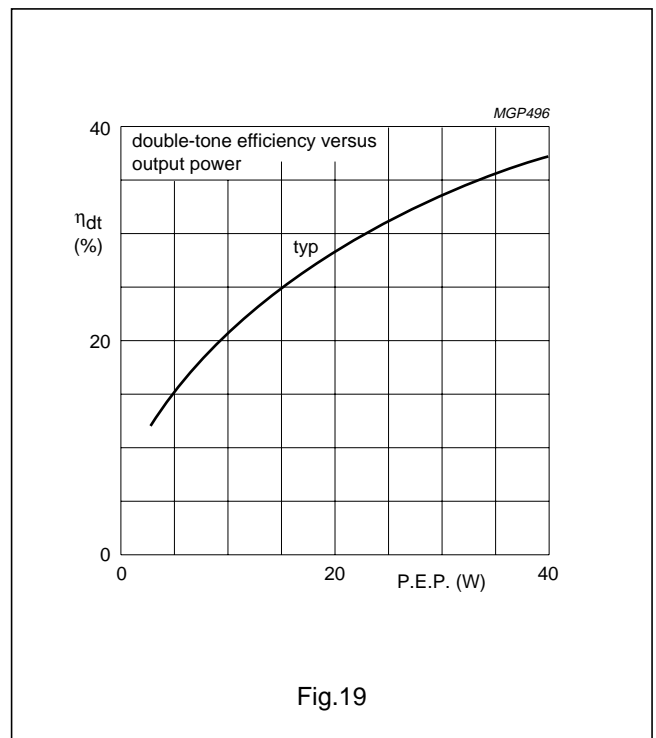
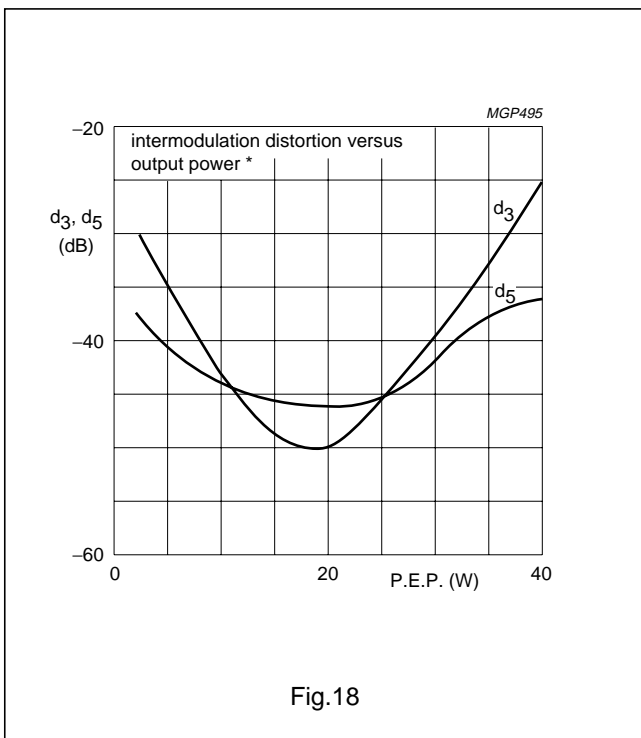
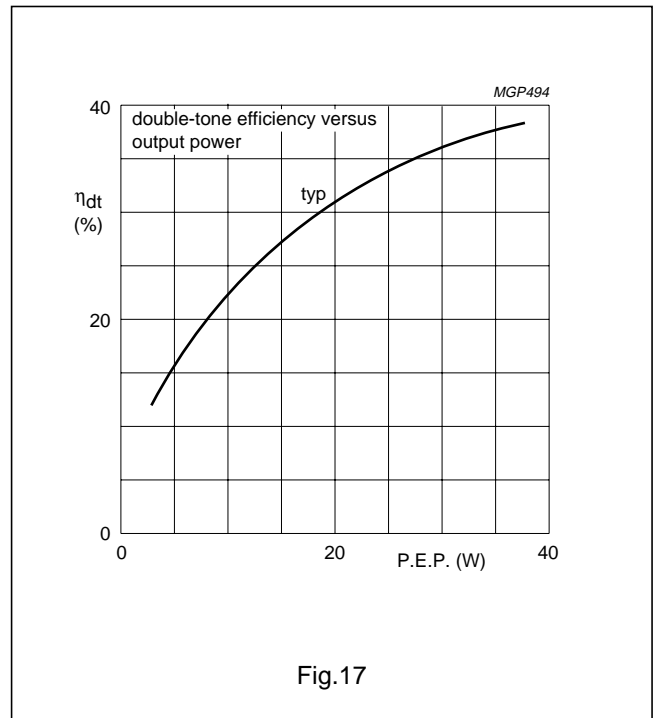
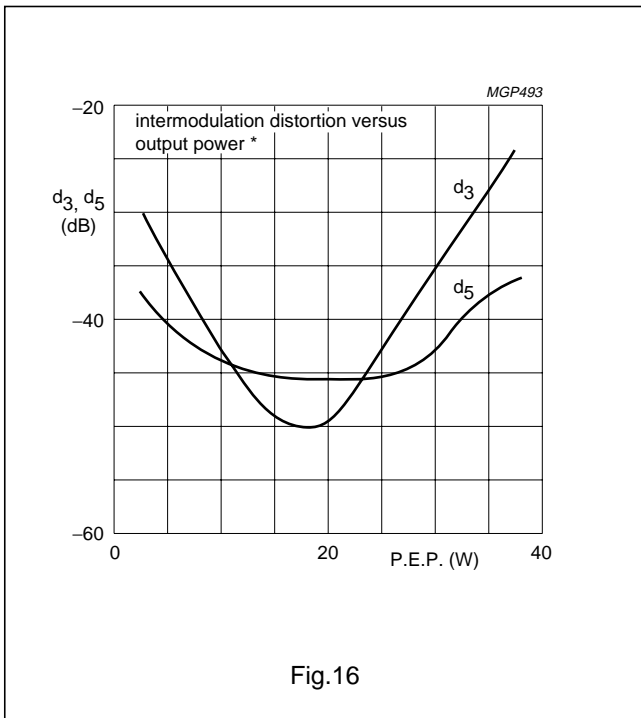

* Stated intermodulation distortion figures are referred to the according level of either of the equal amplified tones. Relative to the according peak envelope powers these figures should be increased by 6 dB.

VHF power transistor

BLW60C

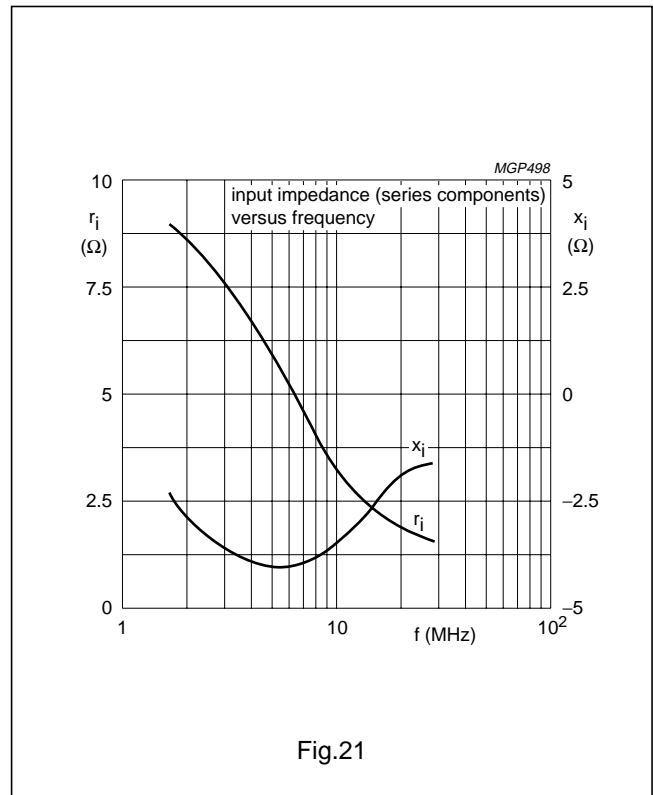
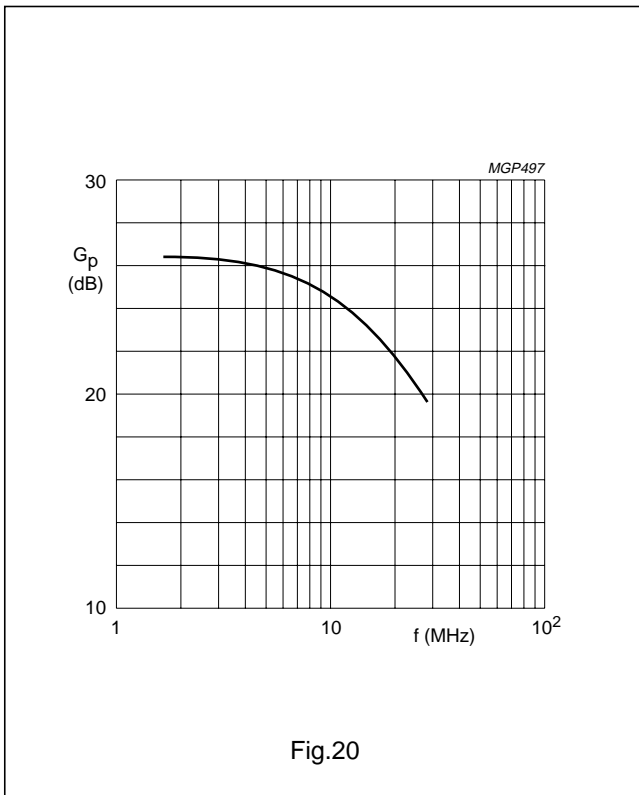

S.S.B. class-AB operation

Conditions for Figs 20 and 21:

- $V_{CC} = 12,5 \text{ V}$
- $P_L = 30 \text{ W (P.E.P.)}$
- $T_h = 25 \text{ }^\circ\text{C}$
- $R_{th \text{ mb-h}} \leq 0,45 \text{ K/W}$
- $I_{C(ZS)} = 25 \text{ mA}$
- $Z_L = 1,9 \text{ } \Omega$

- $V_{CC} = 13,5 \text{ V}$
- $P_L = 35 \text{ W (P.E.P.)}$
- $T_h = 25 \text{ }^\circ\text{C}$
- $R_{th \text{ mb-h}} \leq 0,45 \text{ K/W}$
- $I_{C(ZS)} = 25 \text{ mA}$
- $Z_L = 1,9 \text{ } \Omega$

The typical curves (both conditions) hold for an unneutralized amplifier.

VHF power transistor

BLW60C

PACKAGE OUTLINE

Studded ceramic package; 4 leads

SOT120A

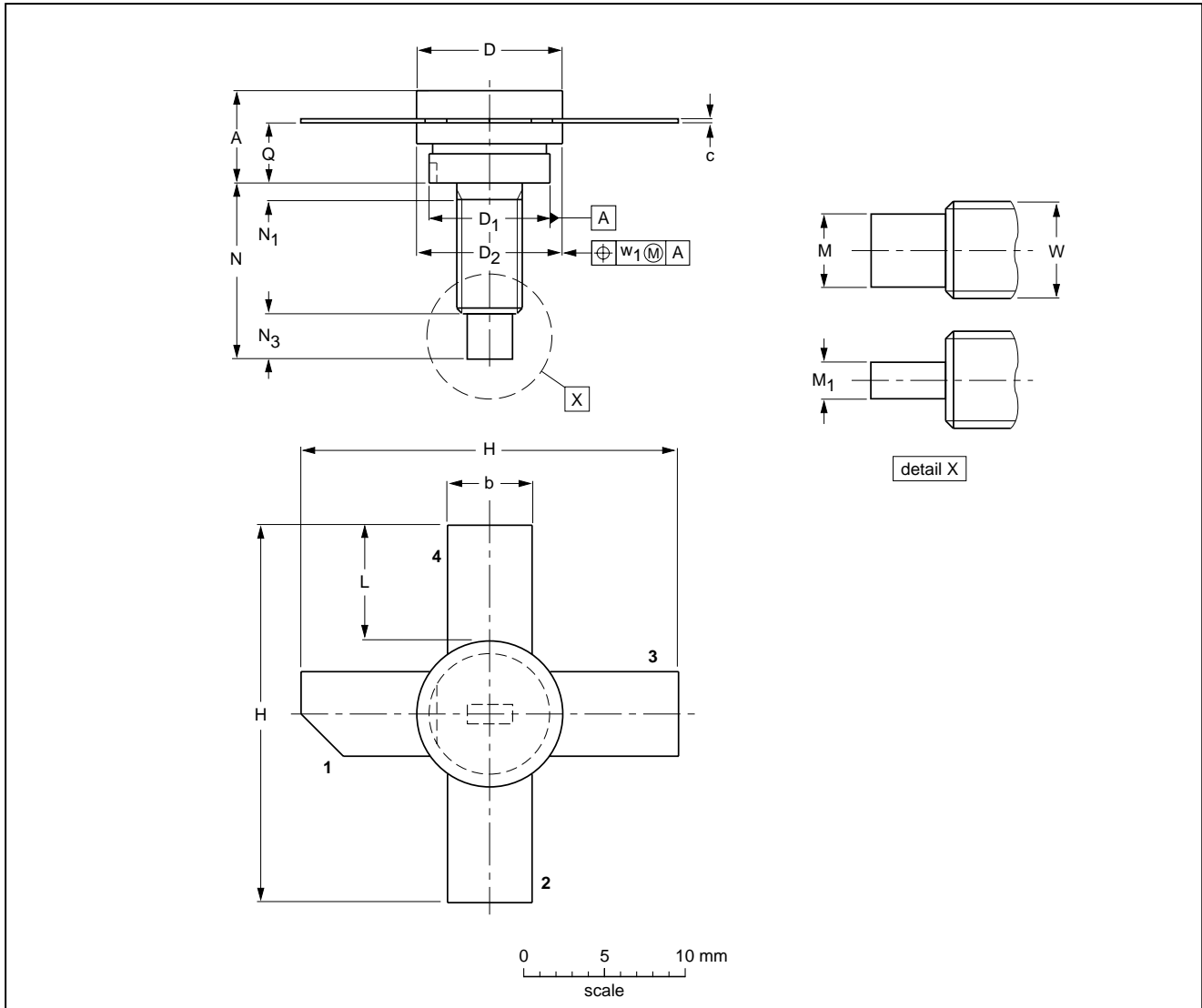

DIMENSIONS (millimetre dimensions are derived from the original inch dimensions)

UNIT	A	b	c	D	D ₁	D ₂	H	L	M	M ₁	N	N ₁	N ₃	Q	W	w ₁
mm	5.97 4.74	5.90 5.48	0.18 0.14	9.73 9.47	8.39 8.12	9.66 9.39	27.44 25.78	9.00 8.00	3.41 2.92	1.66 1.39	12.83 11.17	1.60 0.00	3.31 2.54	4.35 3.98	8-32 UNC	0.38
inches	0.283 0.248	0.232 0.216	0.007 0.004	0.383 0.373	0.330 0.320	0.380 0.370	1.080 1.015	0.354 0.315	0.134 0.115	0.065 0.055	0.505 0.440	0.063 0.000	0.130 0.100	0.171 0.157		0.015

OUTLINE VERSION	REFERENCES				EUROPEAN PROJECTION	ISSUE DATE
	IEC	JEDEC	EIAJ			
SOT120A						97-06-28

VHF power transistor

BLW60C

DEFINITIONS

Data Sheet Status	
Objective specification	This data sheet contains target or goal specifications for product development.
Preliminary specification	This data sheet contains preliminary data; supplementary data may be published later.
Product specification	This data sheet contains final product specifications.
Limiting values	
Limiting values given are in accordance with the Absolute Maximum Rating System (IEC 134). Stress above one or more of the limiting values may cause permanent damage to the device. These are stress ratings only and operation of the device at these or at any other conditions above those given in the Characteristics sections of the specification is not implied. Exposure to limiting values for extended periods may affect device reliability.	
Application information	
Where application information is given, it is advisory and does not form part of the specification.	

LIFE SUPPORT APPLICATIONS

These products are not designed for use in life support appliances, devices, or systems where malfunction of these products can reasonably be expected to result in personal injury. Philips customers using or selling these products for use in such applications do so at their own risk and agree to fully indemnify Philips for any damages resulting from such improper use or sale.



LittleDiode supplies new, hard to find or obsolete electronic components and semiconductors all over the world.

With over two million different components listed you are sure to find the part you need.

Feel free to visit us today at our online store:

LittleDiode.com

Looking forward to providing you with the best possible service.