

2SK1197

SILICON N-CHANNEL ENHANCEMENT MOS FET

高周波増幅

■特長

- 静電破壊耐量が大きい ($C = 200\text{pF}$)
 - ・ ゲート・ソース間 500V typ.
 - ・ ドレイン・ソース間 $1000\text{V min., } 1500\text{V typ.}$
- 順伝達アドミタンスが大きい。
 - $|y_{fs}| = 150\text{mS typ.}$
- 高耐圧である。 $V_{DSS} = 100\text{V}$
- 出力容量 ($C_{oss} \leq 10\text{pF}$) が小さい。

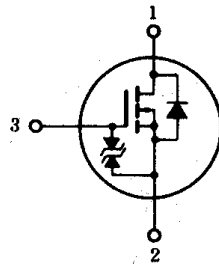

1. Source
2. Drain
3. Gate
(Dimensions in mm)

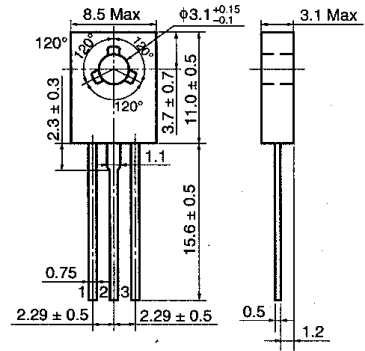

(JEDEC TO-126 MOD.)

■ABSOLUTE MAXIMUM RATINGS ($T_a = 25^\circ\text{C}$)

Item	Symbol	Rating	Unit
Drain to Source Voltage	V_{DSS}	100	V
Gate to Source Voltage	V_{GSS}	± 9	V
Drain Current	I_D	0.5	A
Drain Peak Current	$I_{D(\text{peak})}$	1.0	A
Channel Power Dissipation	P_{ca}	1.25	W
Channel Power Dissipation	P_{ca}^*	20	W
Channel Temperature	T_{ca}	150	$^\circ\text{C}$
Storage Temperature	T_{stg}	$-55 \sim +150$	$^\circ\text{C}$

*Value at $T_c = 25^\circ\text{C}$

POWER VS. TEMPERATURE DERATING

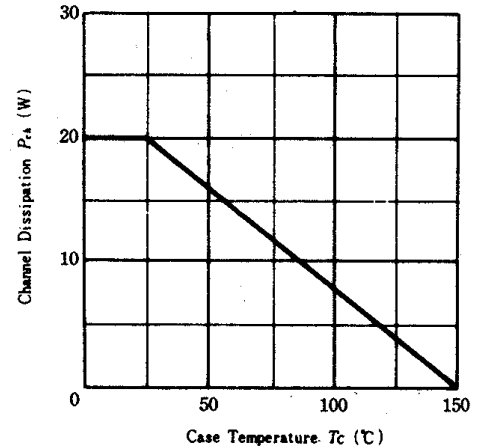

■ELECTRICAL CHARACTERISTICS ($T_a = 25^\circ\text{C}$)

Item	Symbol	Test Condition	min.	typ.	max.	Unit
Drain to Source Breakdown Voltage	$V_{(BR)DSS}$	$I_D = 1\text{mA}, V_{GS} = 0$	100	—	—	V
Gate to Source Breakdown Voltage	$V_{(BR)GSS}$	$I_G = \pm 1\text{mA}, V_{DS} = 0$	± 9	—	—	V
Drain Current	I_{DSS}	$V_{DS} = 80\text{V}, V_{GS} = 0$	—	—	0.1	mA
Gate to Source Cutoff Voltage	$V_{GS(\text{off})}$	$I_D = 1\text{mA}, V_{DS} = 10\text{V}$	0.3	—	1.8	V
Drain to Source ON Voltage	$V_{DS(\text{on})}$	$I_D = 0.2\text{A}, V_{GS} = 9\text{V}$	—	—	5.0	V
Forward Transfer Admittance	$ y_{fs} $	$I_D = 0.3\text{A}, V_{DS} = 10\text{V}$	100	150	—	mS
Input Capacitance	C_{iss}	$V_{DS} = 50\text{V}, V_{GS} = 0,$	—	10	—	pF
Output Capacitance	C_{oss}	$f = 1\text{MHz}$	—	4	10	pF