

**HIGH CURRENT NPN SILICON TRANSISTOR**

- SGS-THOMSON PREFERRED SALESTYPE
- NPN TRANSISTOR

**DESCRIPTION**

The BUR51 is a silicon multiepitaxial planar NPN transistor in modified Jedec TO-3 metal case, intended for use in switching and linear applications in military and industrial equipment.

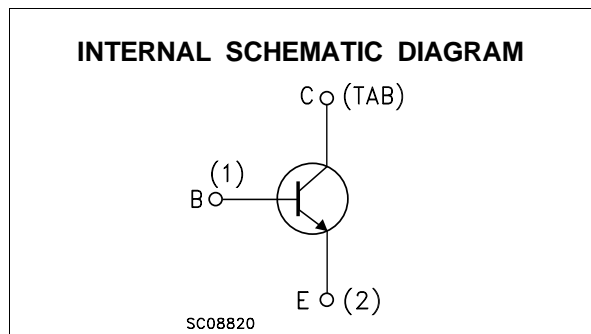
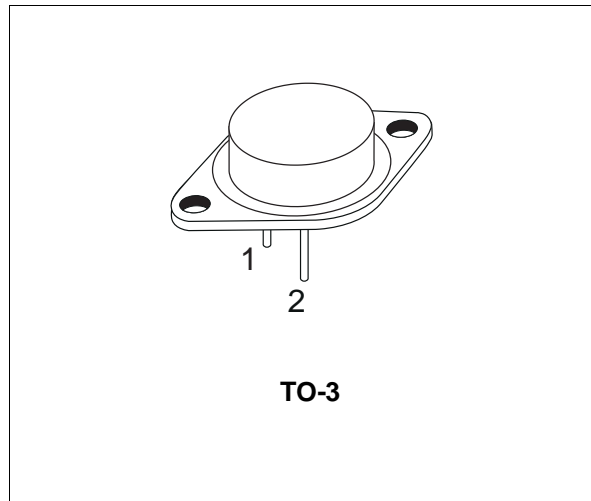

**ABSOLUTE MAXIMUM RATINGS**

Symbol	Parameter	Value	Unit
$V_{CBO}$	Collector-Base Voltage ( $I_E = 0$ )	300	V
$V_{CEO}$	Collector-Emitter Voltage ( $I_B = 0$ )	200	V
$V_{EBO}$	Emitter-Base Voltage ( $I_C = 0$ )	10	V
$I_C$	Collector Current	60	A
$I_{CM}$	Collector Peak Current ( $t_p = 10$ ms)	80	A
$I_B$	Base Current	16	A
$P_{tot}$	Total Dissipation at $T_c \leq 25$ °C	350	W
$T_{stg}$	Storage Temperature	-65 to 200	°C
$T_j$	Max. Operating Junction Temperature	200	°C

## BUR51

### THERMAL DATA

$R_{thj-case}$	Thermal Resistance Junction-case	Max	0.5	$^{\circ}C/W$
----------------	----------------------------------	-----	-----	---------------

### ELECTRICAL CHARACTERISTICS ( $T_{case} = 25^{\circ}C$ unless otherwise specified)

Symbol	Parameter	Test Conditions	Min.	Typ.	Max.	Unit
$I_{CBO}$	Collector Cut-off Current ( $I_E = 0$ )	$V_{CB} = 300 V$ $V_{CB} = 300 V$ $T_{case} = 125^{\circ}C$			0.2 2	mA mA
$I_{CEO}$	Collector Cut-off Current ( $I_B = 0$ )	$V_{CE} = 200 V$			1	mA
$I_{EBO}$	Emitter Cut-off Current ( $I_C = 0$ )	$V_{EB} = 7 V$			0.2	$\mu A$
$V_{CEO(sus)}^*$	Collector-Emitter Sustaining Voltage	$I_C = 200 mA$	200			V
$V_{EBO}$	Emitter-base Voltage ( $I_C = 0$ )	$I_E = 10 mA$	10			V
$V_{CE(sat)}^*$	Collector-emitter Saturation Voltage	$I_C = 30 A$ $I_B = 2 A$ $I_C = 50 A$ $I_B = 5 A$		0.9	1 1.5	V V
$V_{BE(sat)}^*$	Base-emitter Saturation Voltage	$I_C = 30 A$ $I_B = 2 A$ $I_C = 50 A$ $I_B = 5 A$		1.55	1.8 2	V V
$h_{FE}^*$	DC Current Gain	$I_C = 5 A$ $V_{CE} = 4 V$ $I_C = 50 A$ $V_{CE} = 4 V$	20 15		100	
$I_{s/b}$	Second Breakdown Collector Current	$V_{CE} = 20 V$ $t = 1 s$	17.5			A
$f_T$	Transition-Frequency	$I_C = 1 A$ $V_{CE} = 5 V$ $f = 1 MHz$	10	16		MHz
$t_{on}$	Turn-on Time	$I_C = 50 A$ $I_{B1} = 5 A$ $V_{CC} = 100 V$		0.35	1	$\mu s$
$t_s$	Storage Time	$I_C = 50 A$ $I_{B1} = 5 A$ $I_{B2} = -5 A$ $V_{CC} = 100 V$		0.9	2	$\mu s$
$t_f$	Fall Time			0.24	0.6	$\mu s$
	Clamped $E_{s/b}$ Collector Current	$V_{clamp} = 200 V$ $L = 500 \mu H$	50			A

\* Pulsed: Pulse duration = 300  $\mu s$ , duty cycle 1.5 %

**TO-3 (I) MECHANICAL DATA**

DIM.	mm			inch		
	MIN.	TYP.	MAX.	MIN.	TYP.	MAX.
A	11	11.7	13.1	0.433	0.461	0.516
B	1.45	1.5	1.6	0.057	0.059	0.063
C	2.7		2.92	0.106		0.115
D	8.9		9.4	0.350		0.370
E	19		20	0.748		0.787
G	10.7	10.9	11.1	0.421	0.429	0.437
N	16.5	16.9	17.2	0.650	0.665	0.677
P	25		26	0.984		1.024
R	3.88		4.2	0.153		0.165
U	38.5		39.3	1.516		1.547
V	30	30.14	30.3	1.181	1.187	1.193

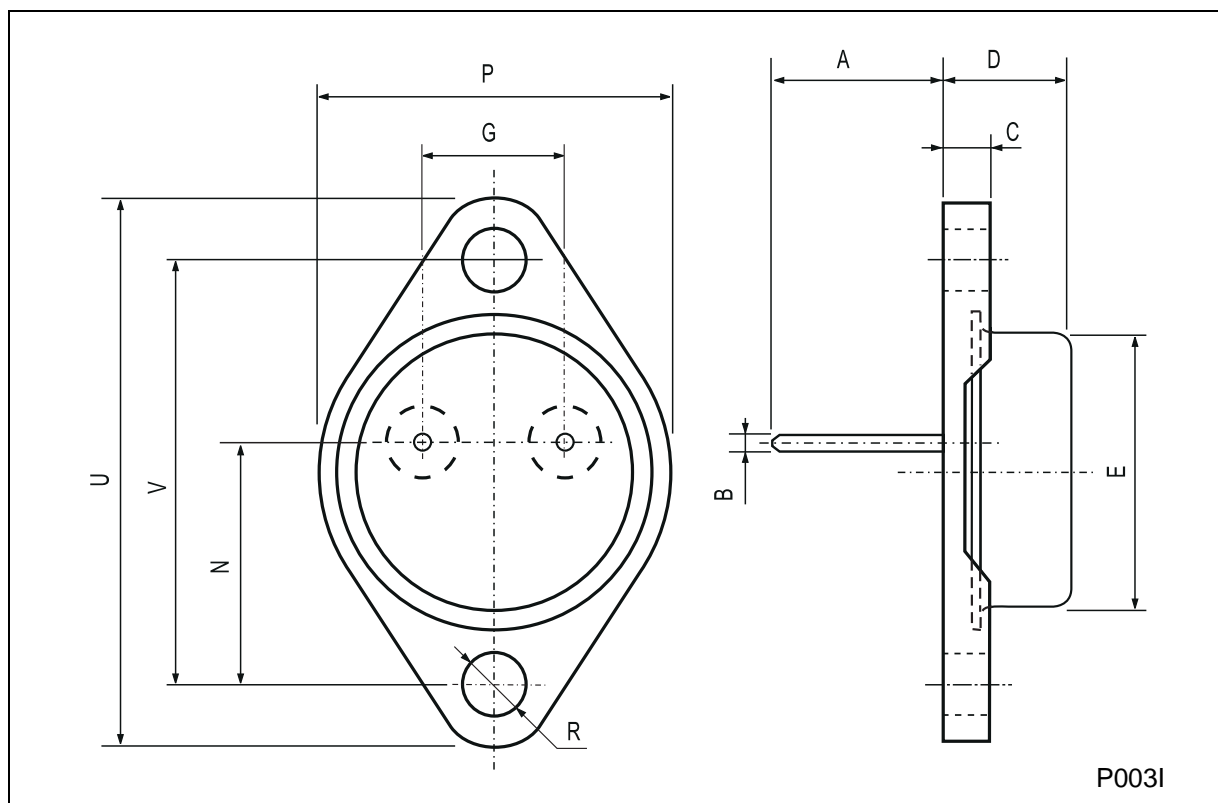

Information furnished is believed to be accurate and reliable. However, SGS-THOMSON Microelectronics assumes no responsibility for the consequences of use of such information nor for any infringement of patents or other rights of third parties which may result from its use. No license is granted by implication or otherwise under any patent or patent rights of SGS-THOMSON Microelectronics. Specifications mentioned in this publication are subject to change without notice. This publication supersedes and replaces all information previously supplied. SGS-THOMSON Microelectronics products are not authorized for use as critical components in life support devices or systems without express written approval of SGS-THOMSON Microelectronics.

© 1997 SGS-THOMSON Microelectronics - Printed in Italy - All Rights Reserved

SGS-THOMSON Microelectronics GROUP OF COMPANIES  
Australia - Brazil - Canada - China - France - Germany - Hong Kong - Italy - Japan - Korea - Malaysia - Malta - Morocco - The Netherlands -  
Singapore - Spain - Sweden - Switzerland - Taiwan - Thailand - United Kingdom - U.S.A  
...



LittleDiode supplies new, hard to find or obsolete electronic components and semiconductors all over the world.

With over two million different components listed you are sure to find the part you need.

Feel free to visit us today at our online store:

**[LittleDiode.com](http://LittleDiode.com)**

Looking forward to providing you with the best possible service.