

MOTOROLA SEMICONDUCTOR TECHNICAL DATA

T-33-07

MRF433

The RF Line

SILICON RF POWER TRANSISTORS

... designed primarily for application as complementary symmetry amplifiers in linear amplifiers from 2.0 to 30 MHz.

- Specified 12.5 Volt, 30 MHz Characteristics –
Output Power = 12.5 W (PEP)
Minimum Gain = 20 dB
Efficiency = 50%
- Intermodulation Distortion @ 12.5 W (PEP) –
IMD = -30 dB (Max)

12.5 W (PEP) – 30 MHz

RF POWER TRANSISTOR

NPN SILICON

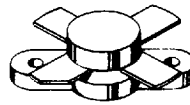

MAXIMUM RATINGS

Rating	Symbol	Value	Unit
Collector-Emitter Voltage	V _{CEO}	18	Vdc
Collector-Base Voltage	V _{CBO}	36	Vdc
Emitter-Base Voltage	V _{EBO}	4.0	Vdc
Collector Current – Continuous	I _C	2.5	Adc
Total Device Dissipation @ T _C = 25°C Derate above 25°C	P _D	20 114	Watts W/°C
Storage Temperature Range	T _{stg}	-65 to +150	°C

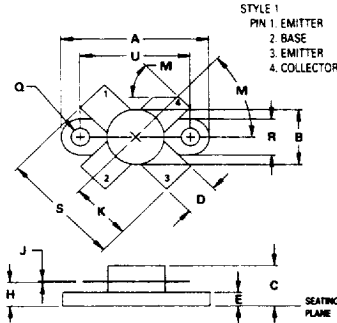

NOTES
1. DIMENSIONING AND TOLERANCING PER ANSI Y14.5M, 1982
2. CONTROLLING DIMENSION: INCH

DIM	MILLIMETERS		INCHES	
	MIN	MAX	MIN	MAX
A	24.39	25.14	0.960	0.990
B	9.40	9.90	0.370	0.390
C	5.82	7.13	0.229	0.281
D	5.47	5.96	0.215	0.235
E	2.16	2.66	0.085	0.105
H	3.81	4.57	0.150	0.180
J	0.11	0.15	0.004	0.006
K	10.04	10.28	0.395	0.405
M	40°	50°	40°	50°
Q	2.88	3.30	0.113	0.130
R	8.23	8.47	0.246	0.255
S	20.07	20.57	0.790	0.810
U	18.29	18.54	0.720	0.730

CASE 211-07

MRF433

MOTOROLA SC (XSTRS/R F)

46E D

6367254 0094663 & MOT6

ELECTRICAL CHARACTERISTICS (T_C = 25°C unless otherwise noted.)

T-33-07

Characteristic	Symbol	Min	Typ	Max	Unit
OFF CHARACTERISTICS					
Collector-Emitter Breakdown Voltage (I _C = 20 mA, I _B = 0)	V _{(BR)CEO}	18	-	-	V _{dc}
Collector-Emitter Breakdown Voltage (I _C = 10 mA, V _{BE} = 0)	V _{(BR)CES}	36	-	-	V _{dc}
Emitter-Base Breakdown Voltage (I _E = 2.0 mA, I _C = 0)	V _{(BR)EBO}	4.0	-	-	V _{dc}
Collector Cutoff Current (V _{CE} = 15 V _{dc} , V _{BE} = 0, T _C = 55°C)	I _{CES}	-	-	8.0	mA _{dc}
Collector Cutoff Current (V _{CB} = 15 V _{dc} , I _E = 0)	I _{CBO}	-	-	0.5	mA _{dc}
ON CHARACTERISTICS					
DC Current Gain (I _C = 0.5 A _{dc} , V _{CE} = 5.0 V _{dc})	h _{FE}	15	-	-	-
DYNAMIC CHARACTERISTICS					
Output Capacitance (V _{CB} = 15 V _{dc} , I _E = 0, f = 1.0 MHz)	C _{ob}	-	70	120	pF
FUNCTIONAL TESTS					
Common-Emitter Amplifier Power Gain ⁽¹⁾ (V _{CC} = 12.5 V _{dc} , P _{out} = 12.5 W (PEP), I _{CQ} = 100 mA _{dc} , f = 30, 30.001 MHz)	G _{pe}	20	-	-	dB
Collector Efficiency (V _{CC} = 12.5 V _{dc} , P _{out} = 12.5 W (PEP), f = 30, 30.001 MHz)	η ⁽¹⁾ η ⁽²⁾	45 40	50 45	-	%
Intermodulation Distortion ⁽³⁾ (V _{CC} = 12.5 V _{dc} , P _{out} = 12.5 W (PEP), I _{CQ} = 100 mA _{dc} , f = 30, 30.001 MHz)	IMD	-	-	-30	dB
Series Equivalent Input Impedance (V _{CC} = 12.5 V _{dc} , P _{out} = 12.5 W (PEP), I _{CQ} = 100 mA _{dc} , f = 30, 30.001 MHz)	Z _{in}	-	2.50-j2.20	-	Ohms
Series Equivalent Output Impedance (V _{CC} = 12.5 V _{dc} , P _{out} = 12.5 W (PEP), I _{CQ} = 100 mA _{dc} , f = 30, 30.001 MHz)	Z _{out}	-	4.80-j3.00	-	Ohms

- (1) Class AB
- (2) Class A
- (3) To Mil-Std-1311 Version A, Test Method 2204B, Two Tone, Reference each Tone

FIGURE 1 - 30 MHz TEST CIRCUIT SCHEMATIC

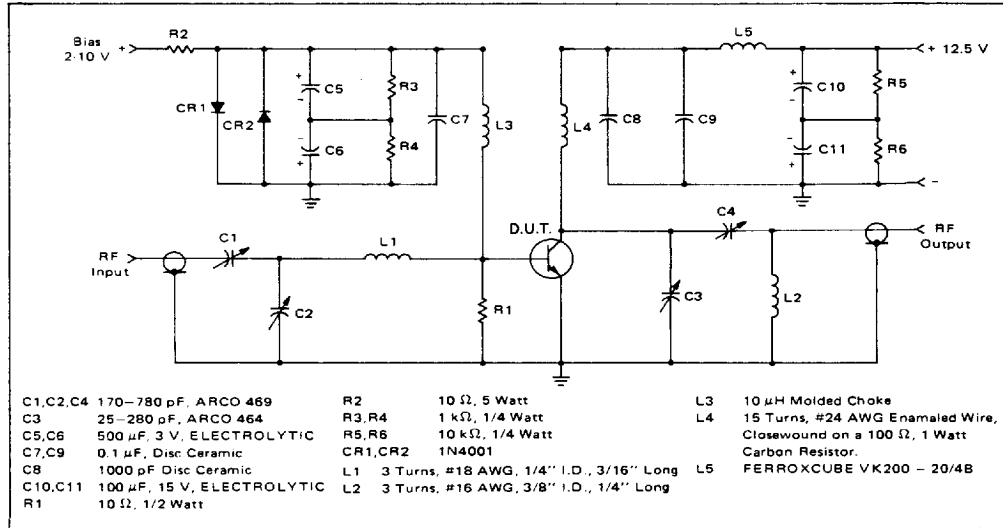

MOTOROLA RF DEVICE DATA

2-641