

# Designer's™ Data Sheet

## SWITCHMODE Series

### NPN Silicon Power Transistors

These transistors are designed for high-voltage, high-speed, power switching in inductive circuits where fall time is critical. They are particularly suited for line-operated switchmode applications. The MJ16012 and MJW16012 are selected high gain versions of the MJ16010 and MJW16010 for applications where drive current is limited.

- Switching Regulators
- Inverters
- Solenoids
- Relay Drivers
- Motor Controls
- Deflection Circuits
- Fast Turn-Off Times —  $T_C = 100^\circ\text{C}$   
50 ns Inductive Fall Time (Typ)  
90 ns Inductive Crossover Time (Typ)  
800 ns Inductive Storage Time (Typ)
- $100^\circ\text{C}$  Performance Specified for:  
Reverse-Biased SOA with Inductive Loads  
Switching Times with Inductive Loads  
Saturation Voltages  
Leakage Currents

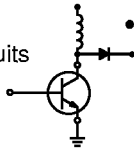

#### MAXIMUM RATINGS

Rating	Symbol	MJ16010 MJ16012	MJW16010 MJW16012	Unit
Collector-Emitter Voltage	$V_{CEO}$	450		Vdc
Collector-Emitter Voltage	$V_{CEV}$	850		Vdc
Emitter-Base Voltage	$V_{EB}$	6.0		Vdc
Collector Current — Continuous	$I_C$	15		Adc
— Peak (1)	$I_{CM}$	20		
Base Current — Continuous	$I_B$	10		Adc
— Peak (1)	$I_{BM}$	15		
Total Device Dissipation @ $T_C = 25^\circ\text{C}$ @ $T_C = 100^\circ\text{C}$ Derate above $25^\circ\text{C}$	$P_D$	1.75 100 1.0	135 53.8 1.11	Watts W/ $^\circ\text{C}$
Operating and Storage Junction Temperature Range	$T_J, T_{stg}$	-65 to 200	-55 to 150	$^\circ\text{C}$

#### THERMAL CHARACTERISTICS

Characteristic	Symbol	Max		Unit
Thermal Resistance, Junction to Case	$R_{\theta JC}$	1.0	0.93	$^\circ\text{C}/\text{W}$
Lead Temperature for Soldering Purposes, 1/8" from Case for 5 Seconds	$T_L$	275		$^\circ\text{C}$

(1) Pulse Test: Pulse Width  $\leq 50 \mu\text{s}$ , Duty Cycle  $\geq 10\%$

**Designer's Data for "Worst Case" Conditions** — The Designer's Data Sheet permits the design of most circuits entirely from the information presented. SOA Limit curves — representing boundaries on device characteristics — are given to facilitate "worst case" design.

**Preferred** devices are Motorola recommended choices for future use and best overall value.

Designer's and SWITCHMODE are trademarks of Motorola, Inc.

REV 2

**MJ16010**  
**MJW16010**  
**MJ16012\***  
**MJW16012\***

\*Motorola Preferred Device

**15 AMPERE**  
**NPN SILICON**  
**POWER TRANSISTORS**  
**450 VOLTS**  
**135 AND 175 WATTS**

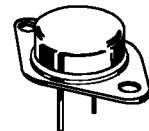

CASE 1-07  
TO-204AA  
(TO-3)  
MJ16010  
MJ16012

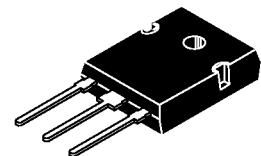

CASE 340F-03  
TO-247AE  
MJW16010  
MJW16012



# MJ16010 MJW16010 MJ16012 MJW16012

## ELECTRICAL CHARACTERISTICS (T<sub>C</sub> = 25°C unless otherwise noted)

Characteristic	Symbol	Min	Typ	Max	Unit
<b>OFF CHARACTERISTICS</b>					
Collector–Emitter Sustaining Voltage (Table 2) (I <sub>C</sub> = 100 mA, I <sub>B</sub> = 0)	V <sub>CEO(sus)</sub>	450	—	—	Vdc
Collector Cutoff Current (V <sub>CEV</sub> = 850 Vdc, V <sub>BE(off)</sub> = 1.5 Vdc) (V <sub>CEV</sub> = 850 Vdc, V <sub>BE(off)</sub> = 1.5 Vdc, T <sub>C</sub> = 100°C)	I <sub>CEV</sub>	—	—	0.25 1.5	mAdc
Collector Cutoff Current (V <sub>CE</sub> = 850 Vdc, R <sub>BE</sub> = 50 Ω, T <sub>C</sub> = 100°C)	I <sub>CER</sub>	—	—	2.5	mAdc
Emitter Cutoff Current (V <sub>EB</sub> = 6.0 Vdc, I <sub>C</sub> = 0)	I <sub>EBO</sub>	—	—	10	mAdc

## SECOND BREAKDOWN

Second Breakdown Collector Current with Base Forward Biased	I <sub>S/b</sub>	See Figure 15			
Clamped Inductive SOA with Base Reverse Biased	RBSOA	See Figure 16			

## ON CHARACTERISTICS (1)

Collector–Emitter Saturation Voltage (I <sub>C</sub> = 5.0 Adc, I <sub>B</sub> = 0.7 Adc) (I <sub>C</sub> = 10 Adc, I <sub>B</sub> = 1.3 Adc) (I <sub>C</sub> = 10 Adc, I <sub>B</sub> = 1.3 Adc, T <sub>C</sub> = 100°C)	V <sub>CE(sat)</sub>	—	—	2.5 3.0 3.0	Vdc
Base–Emitter Saturation Voltage (I <sub>C</sub> = 10 Adc, I <sub>B</sub> = 1.3 Adc) (I <sub>C</sub> = 10 Adc, I <sub>B</sub> = 1.3 Adc, T <sub>C</sub> = 100°C)	V <sub>BE(sat)</sub>	—	—	1.5 1.5	Vdc
DC Current Gain (I <sub>C</sub> = 15 Adc, V <sub>CE</sub> = 5.0 Vdc)	h <sub>FE</sub>	5.0	—	—	—

## DYNAMIC CHARACTERISTICS

Output Capacitance (V <sub>CB</sub> = 10 Vdc, I <sub>E</sub> = 0, f <sub>test</sub> = 1.0 kHz)	C <sub>ob</sub>	—	—	400	pF
---	-----------------	---	---	-----	----

## SWITCHING CHARACTERISTICS

Resistive Load (Table 1)							
Delay Time	(I <sub>C</sub> = 10 Adc, V <sub>CC</sub> = 250 Vdc, I <sub>B1</sub> = 1.3 Adc, PW = 30 μs, Duty Cycle ≤ 2.0%)	(I <sub>B2</sub> = 2.6 Adc, R <sub>B2</sub> = 1.6 Ω)	t <sub>d</sub>	—	20	—	ns
Rise Time			t <sub>r</sub>	—	200	—	
Storage Time			t <sub>s</sub>	—	1200	—	
Fall Time		t <sub>f</sub>	—	200	—		
Storage Time		t <sub>s</sub>	(V <sub>BE(off)</sub> = 5.0 Vdc)	—	650	—	
Fall Time		t <sub>f</sub>		—	80	—	
Inductive Load (Table 2)							
Storage Time	(I <sub>C</sub> = 10 Adc, I <sub>B1</sub> = 1.3 Adc, V <sub>BE(off)</sub> = 5.0 Vdc, V <sub>CE(pk)</sub> = 400 Vdc)	(T <sub>C</sub> = 100°C)	t <sub>sv</sub>	—	800	1800	ns
Fall Time			t <sub>fi</sub>	—	50	200	
Crossover Time			t <sub>c</sub>	—	90	250	
Storage Time		t <sub>sv</sub>	(T <sub>C</sub> = 150°C)	—	1050	—	
Fall Time		t <sub>fi</sub>		—	70	—	
Crossover Time		t <sub>c</sub>		—	120	—	

(1) Pulse Test: Pulse Width = 300 μs, Duty Cycle ≤ 2.0%

**ELECTRICAL CHARACTERISTICS** ( $T_C = 25^\circ\text{C}$  unless otherwise noted)

Characteristic	Symbol	Min	Typ	Max	Unit
<b>OFF CHARACTERISTICS</b>					
Collector–Emitter Sustaining Voltage (Table 2) ( $I_C = 100\text{ mA}$ , $I_B = 0$ )	$V_{CEO(sus)}$	450	—	—	Vdc
Collector Cutoff Current ( $V_{CEV} = 850\text{ Vdc}$ , $V_{BE(off)} = 1.5\text{ Vdc}$ ) ( $V_{CEV} = 850\text{ Vdc}$ , $V_{BE(off)} = 1.5\text{ Vdc}$ , $T_C = 100^\circ\text{C}$ )	$I_{CEV}$	—	—	0.25 1.5	mAdc
Collector Cutoff Current ( $V_{CE} = 850\text{ Vdc}$ , $R_{BE} = 50\ \Omega$ , $T_C = 100^\circ\text{C}$ )	$I_{CER}$	—	—	2.5	mAdc
Emitter Cutoff Current ( $V_{EB} = 6.0\text{ Vdc}$ , $I_C = 0$ )	$I_{EBO}$	—	—	10	mAdc

**SECOND BREAKDOWN**

Second Breakdown Collector Current with Base Forward Biased	$I_{S/b}$	See Figure 15			
Clamped Inductive SOA with Base Reverse Biased	RBSOA	See Figure 16			

**ON CHARACTERISTICS (1)**

Collector–Emitter Saturation Voltage ( $I_C = 5.0\text{ Adc}$ , $I_B = 0.7\text{ Adc}$ ) ( $I_C = 10\text{ Adc}$ , $I_B = 1.0\text{ Adc}$ ) ( $I_C = 10\text{ Adc}$ , $I_B = 1.0\text{ Adc}$ , $T_C = 100^\circ\text{C}$ )	$V_{CE(sat)}$	—	—	2.5 3.0 3.0	Vdc
Base–Emitter Saturation Voltage ( $I_C = 10\text{ Adc}$ , $I_B = 1.0\text{ Adc}$ ) ( $I_C = 10\text{ Adc}$ , $I_B = 1.0\text{ Adc}$ , $T_C = 100^\circ\text{C}$ )	$V_{BE(sat)}$	—	—	1.5 1.5	Vdc
DC Current Gain ( $I_C = 15\text{ Adc}$ , $V_{CE} = 5.0\text{ Vdc}$ )	$h_{FE}$	7.0	—	—	—

**DYNAMIC CHARACTERISTICS**

Output Capacitance ( $V_{CB} = 10\text{ Vdc}$ , $I_E = 0$ , $f_{test} = 1.0\text{ kHz}$ )	$C_{ob}$	—	—	400	pF
--	----------	---	---	-----	----

**SWITCHING CHARACTERISTICS**

<b>Resistive Load (Table 1)</b>							
Delay Time	$(I_C = 10\text{ Adc}$ , $V_{CC} = 250\text{ Vdc}$ , $I_{B1} = 1.0\text{ Adc}$ , $PW = 30\ \mu\text{s}$ , Duty Cycle $\leq 2.0\%$ )	$(I_{B2} = 2.0\text{ Adc}$ , $R_{B2} = 1.6\ \Omega)$	$t_d$	—	20	—	ns
Rise Time			$t_r$	—	200	—	
Storage Time			$t_s$	—	900	—	
Fall Time		$t_f$	—	150	—		
Storage Time		$(V_{BE(off)} = 5.0\text{ Vdc})$	$t_s$	—	500	—	
Fall Time			$t_f$	—	40	—	
<b>Inductive Load (Table 2)</b>							
Storage Time	$(I_C = 10\text{ Adc}$ , $I_{B1} = 1.0\text{ Adc}$ , $V_{BE(off)} = 5.0\text{ Vdc}$ , $V_{CE(pk)} = 400\text{ Vdc}$ )	$(T_C = 100^\circ\text{C})$	$t_{sv}$	—	650	1500	ns
Fall Time			$t_{fi}$	—	30	150	
Crossover Time			$t_c$	—	50	200	
Storage Time		$(T_C = 150^\circ\text{C})$	$t_{sv}$	—	850	—	
Fall Time			$t_{fi}$	—	30	—	
Crossover Time			$t_c$	—	70	—	

(1) Pulse Test: Pulse Width =  $300\ \mu\text{s}$ , Duty Cycle  $\leq 2.0\%$

TYPICAL STATIC CHARACTERISTICS

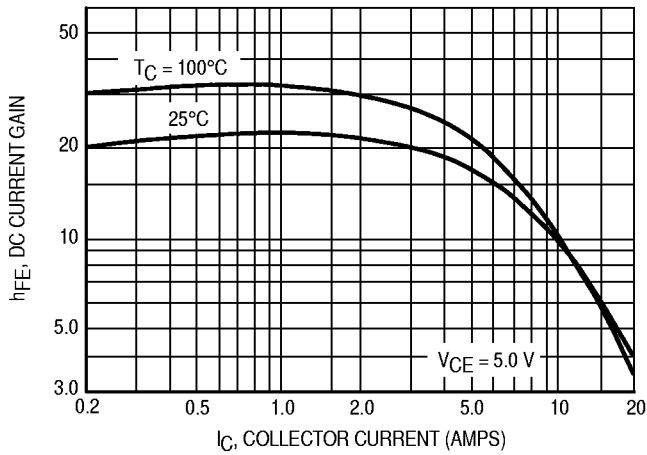

Figure 1. DC Current Gain

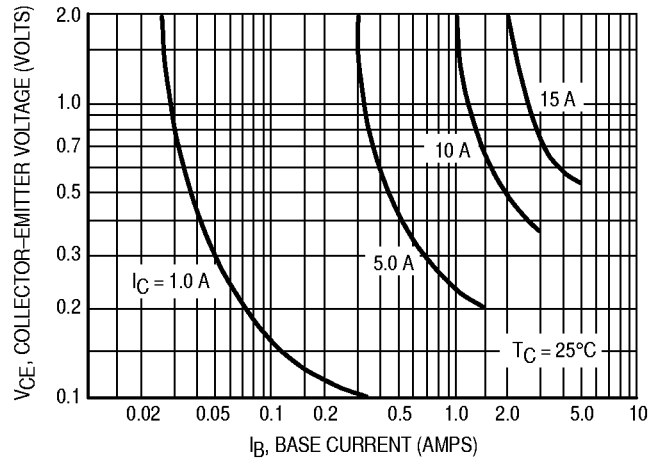

Figure 2. Collector Saturation Region

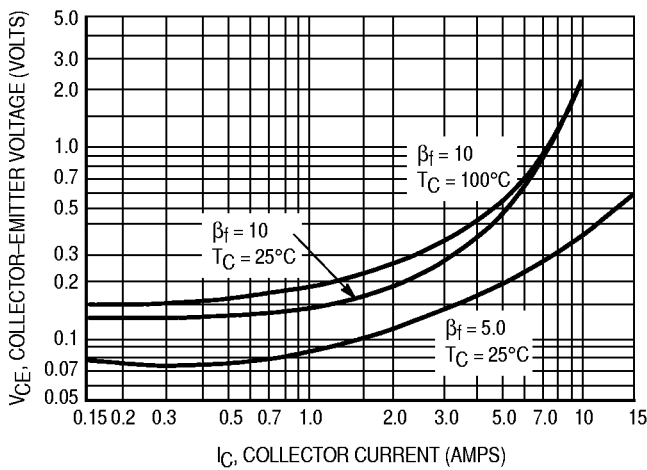

Figure 3. Collector-Emitter Saturation Voltage

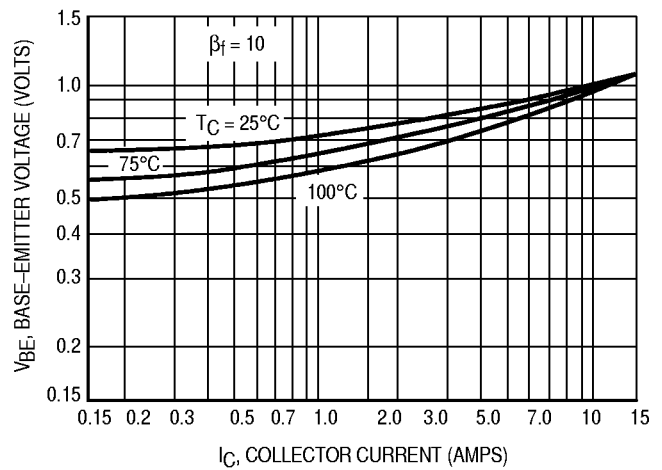

Figure 4. Base-Emitter Voltage

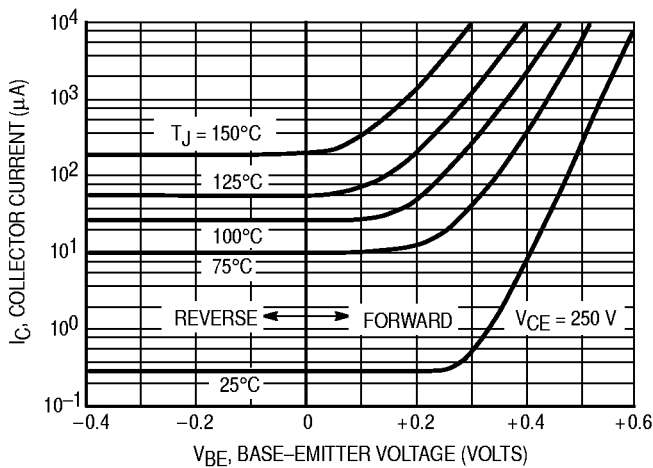

Figure 5. Collector Cutoff Region

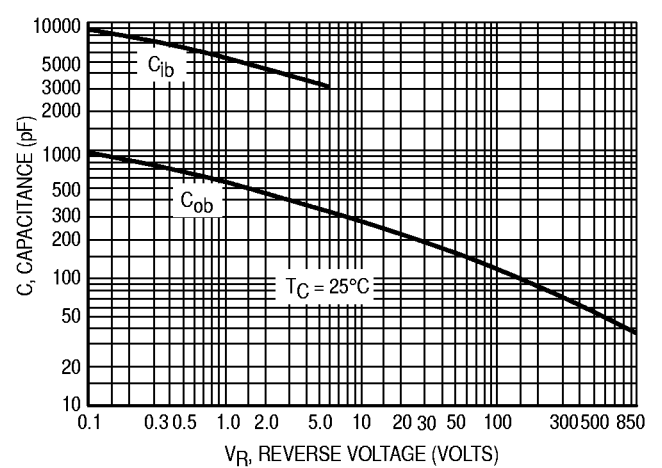

Figure 6. Capacitance

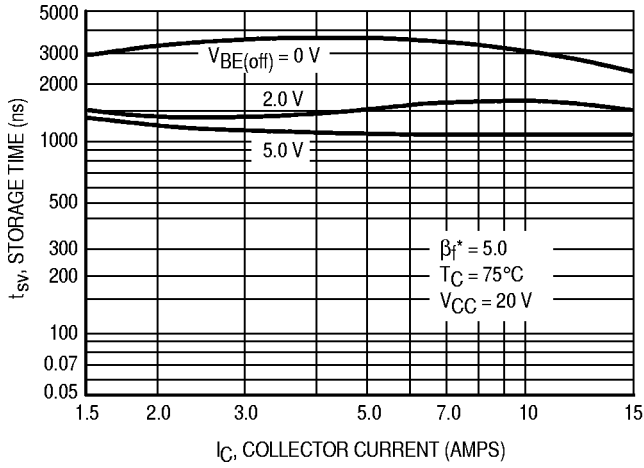

Figure 7. Storage Time

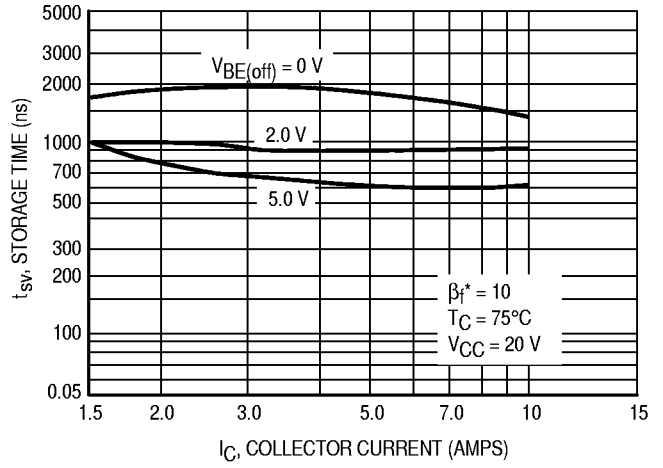

Figure 8. Storage Time

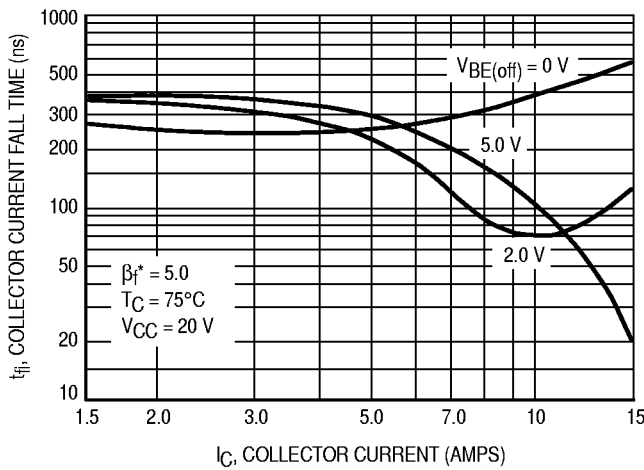

Figure 9. Collector Current Fall Time

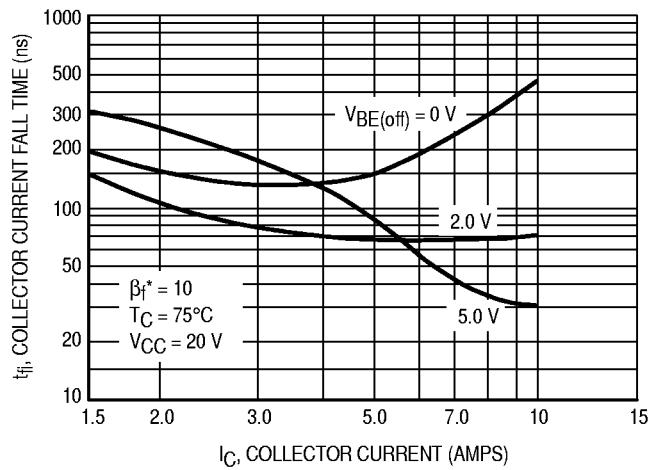

Figure 10. Collector Current Fall Time

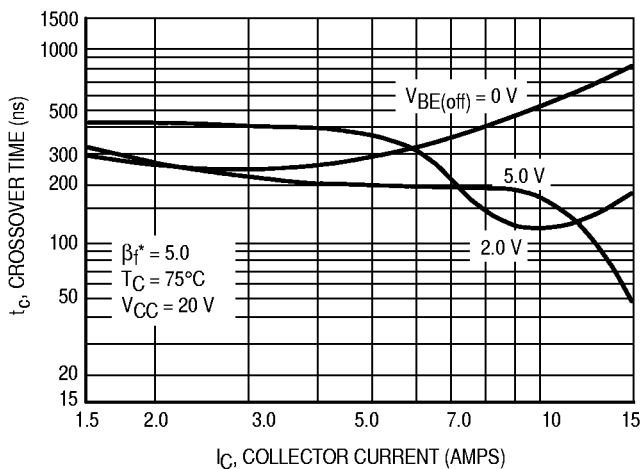

Figure 11. Crossover Time

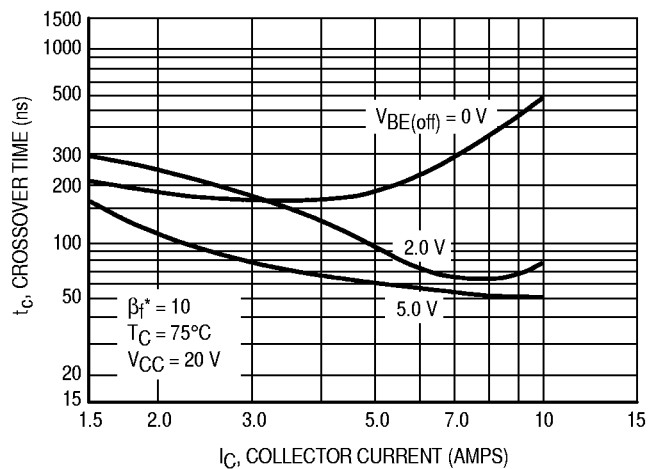

Figure 12. Crossover Time

$$\beta_f^* = \frac{I_C}{I_{B1}}$$

GUARANTEED SAFE OPERATING AREA LIMITS

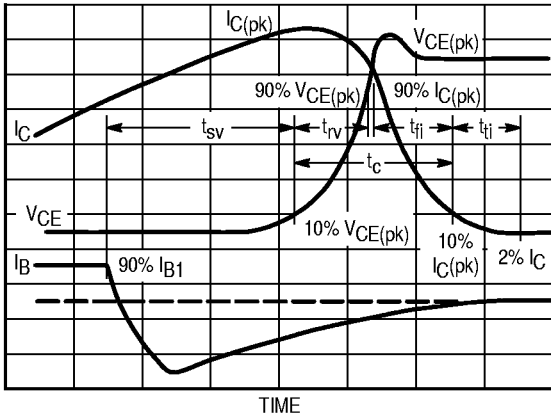

Figure 13. Inductive Switching Measurements

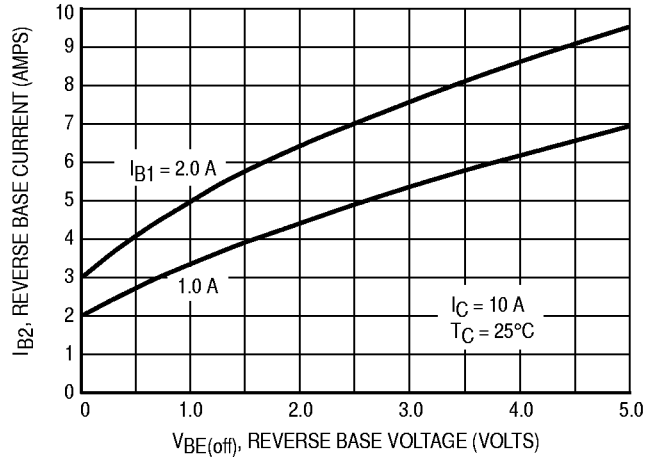

Figure 14. Peak Reverse Base Current

SAFE OPERATING AREA INFORMATION

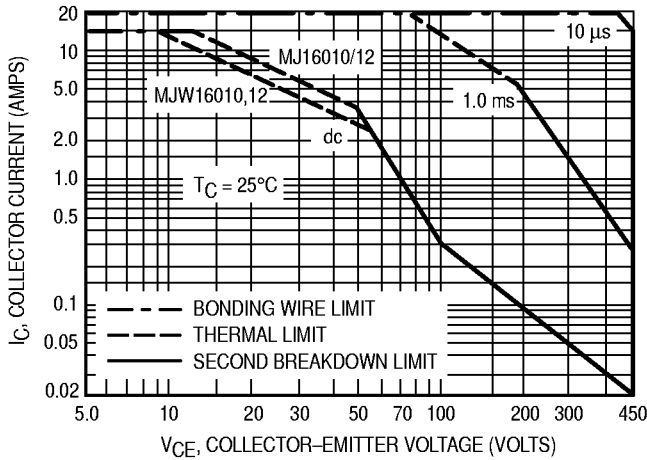

Figure 15. Maximum Forward Bias Safe Operating Area

$$*\beta_f = \frac{I_C}{I_{B1}}$$

FORWARD BIAS

There are two limitations on the power handling ability of a transistor: average junction temperature and second breakdown. Safe operating area curves indicate  $I_C - V_{CE}$  limits of the transistor that must be observed for reliable operation; i.e., the transistor must not be subjected to greater dissipation than the curves indicate.

The data of Figure 15 is based on  $T_C = 25^\circ\text{C}$ ;  $T_J(pk)$  is variable depending on power level. Second breakdown pulse limits are valid for duty cycles to 10% but must be derated when  $T_C \geq 25^\circ\text{C}$ . Second breakdown limitations do not derate the same as thermal limitations. Allowable current at the voltages shown on Figure 15 may be found at any case temperature by using the appropriate curve on Figure 18.

$T_J(pk)$  may be calculated from the data in Figure 17. At high case temperatures, thermal limitations will reduce the

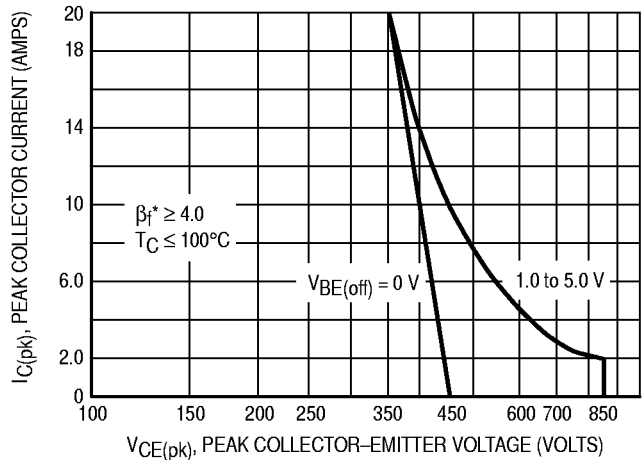

Figure 16. Maximum Reverse Bias Safe Operating Area

power that can be handled to values less than the limitations imposed by second breakdown.

REVERSE BIAS

For inductive loads, high voltage and high current must be sustained simultaneously during turn-off, in most cases, with the base-to-emitter junction reverse biased. Under these conditions the collector voltage must be held to a safe level at or below a specific value of collector current. This can be accomplished by several means such as active clamping, RC snubbing, load line shaping, etc. The safe level for these devices is specified as Reverse Bias Safe Operating Area and represents the voltage current condition allowable during reverse biased turnoff. This rating is verified under clamped conditions so that the device is never subjected to an avalanche mode. Figure 16 gives the RBSOA characteristics.

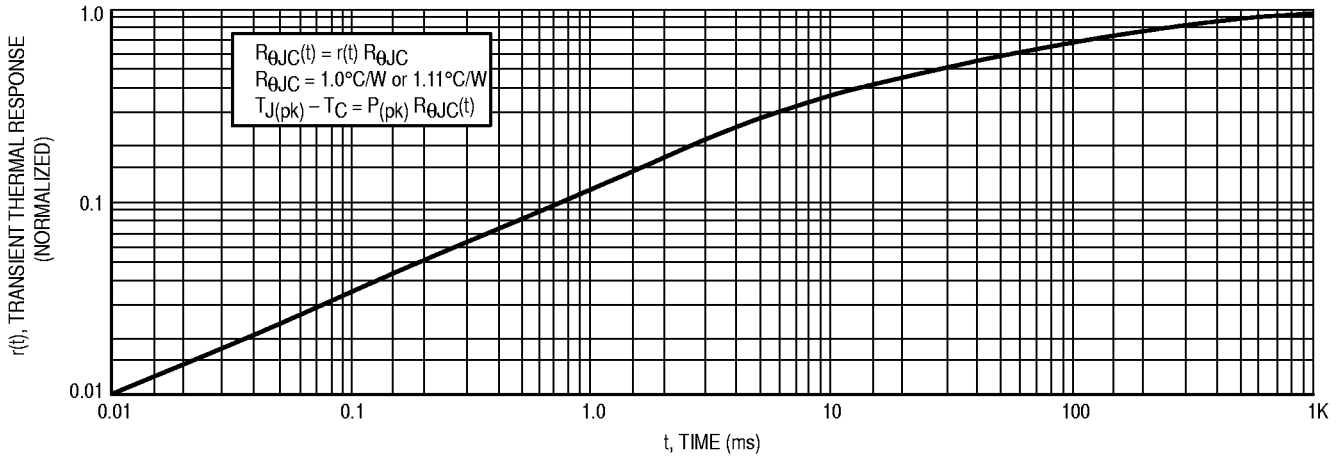

Figure 17. Thermal Response

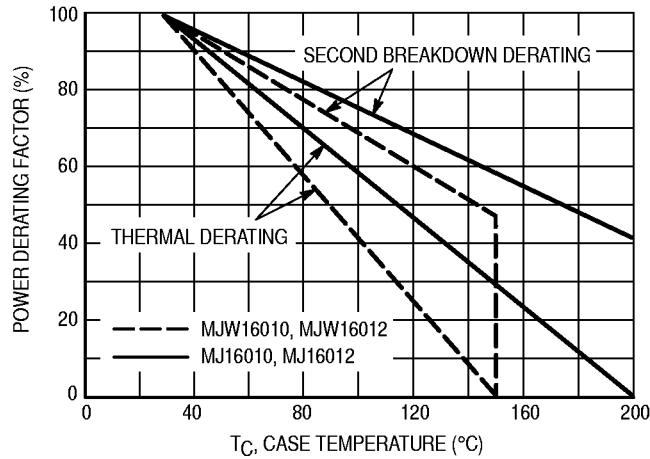
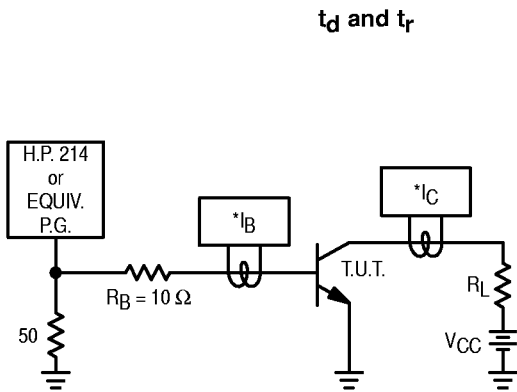
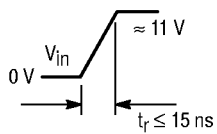

Figure 18. Power Derating

Table 1. Resistive Load Switching



$V_{CC} = 250 \text{ Vdc}$   
 $R_L = 25 \Omega$   
 $I_C = 10 \text{ Adc}$   
 $I_B = 1.0 \text{ Adc}$



\*Tektronix AM503  
 P6302 or Equivalent

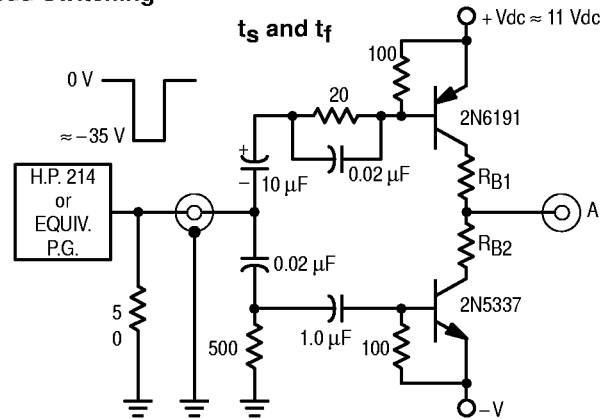

$V_{CC} = 250 \text{ Vdc}$   
 $R_L = 25 \Omega$   
 $I_C = 10 \text{ Adc}$   
 $I_{B1} = 1.0 \text{ Adc}$   
 $I_{B2} = 2.0 \text{ Adc}$   
 For  $V_{BE(off)} = 5.0 \text{ V}$ ,  $R_{B2} = 0 \Omega$   
 $R_{B1} = 10 \Omega$   
 $R_{B2} = 1.6 \Omega$

Note: Adjust  $-V$  to obtain desired  $V_{BE(off)}$  at Point A.

Table 2. Inductive Load Switching

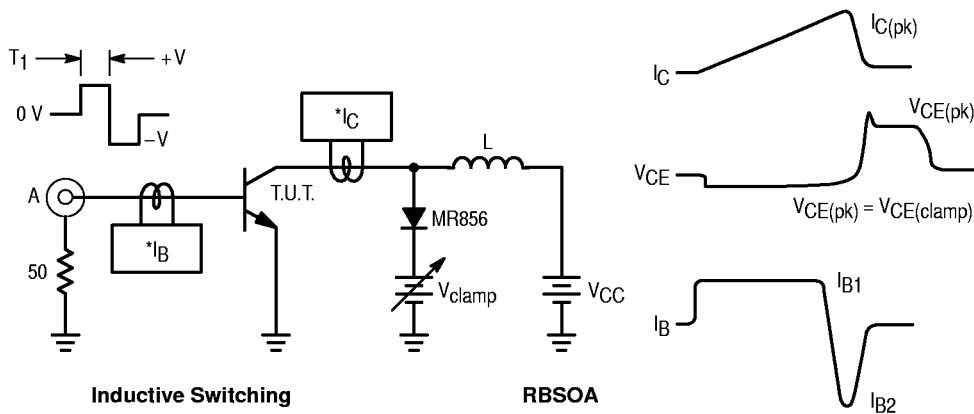
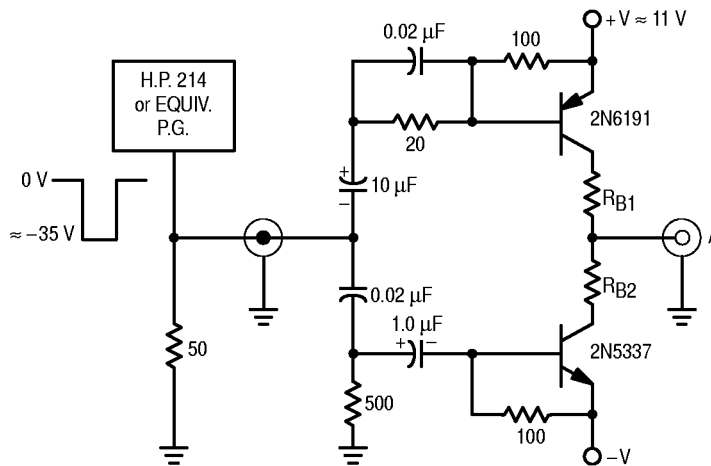

$$t_1 \approx \frac{L_{\text{coil}} (I_{Cpk})}{V_{CC}}$$

T<sub>1</sub> adjusted to obtain I<sub>C(pk)</sub>

**V<sub>CEO(sus)</sub>**

L = 10 mH  
 R<sub>B2</sub> = ∞  
 V<sub>CC</sub> = 20 V Its

\*Tektronix AM503  
 P6302 or Equivalent

**Inductive Switching**

L = 200 μH  
 R<sub>B2</sub> = 0  
 V<sub>CC</sub> = 20 V  
 R<sub>B1</sub> selected for desired I<sub>B1</sub>

Scope — Tektronix  
 7403 or Equivalent

**RBSOA**

L = 200 μH  
 R<sub>B2</sub> = 0  
 V<sub>CC</sub> = 20 V  
 R<sub>B1</sub> selected for desired I<sub>B1</sub>

Note: Adjust -V to obtain desired V<sub>BE(off)</sub> at Point A.

**TYPICAL INDUCTIVE SWITCHING WAVEFORMS**

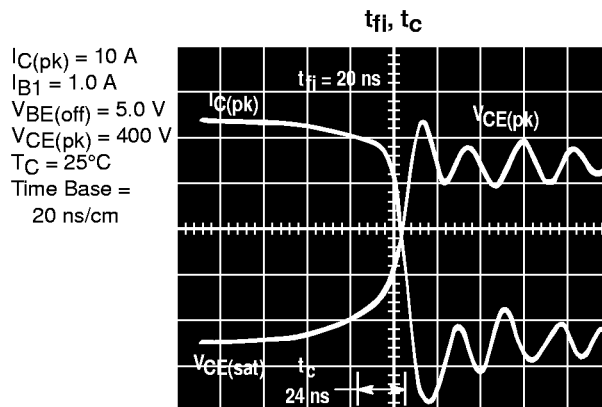
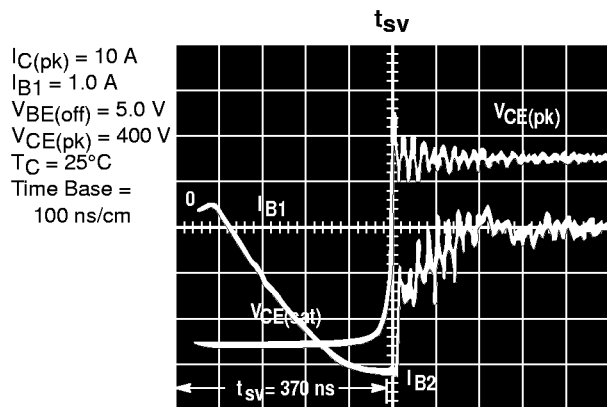

PACKAGE DIMENSIONS

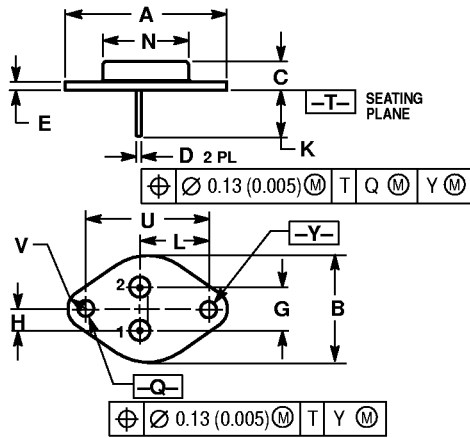

- NOTES:  
 1. DIMENSIONING AND TOLERANCING PER ANSI Y14.5M, 1982.  
 2. CONTROLLING DIMENSION: INCH.  
 3. ALL RULES AND NOTES ASSOCIATED WITH REFERENCED TO-204AA OUTLINE SHALL APPLY.

DIM	INCHES		MILLIMETERS	
	MIN	MAX	MIN	MAX
A	1.550 REF		39.37 REF	
B	—	1.050	—	26.67
C	0.250	0.335	6.35	8.51
D	0.038	0.043	0.97	1.09
E	0.055	0.070	1.40	1.77
G	0.430 BSC		10.92 BSC	
H	0.215 BSC		5.46 BSC	
K	0.440	0.480	11.18	12.19
L	0.665 BSC		16.89 BSC	
N	—	0.830	—	21.08
Q	0.151	0.165	3.84	4.19
U	1.187 BSC		30.15 BSC	
V	0.131	0.188	3.33	4.77

STYLE 1:  
 PIN 1. BASE  
 2. EMITTER  
 CASE: COLLECTOR

CASE 1-07  
 TO-204AA (TO-3)  
 ISSUE Z

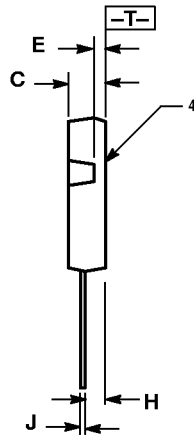
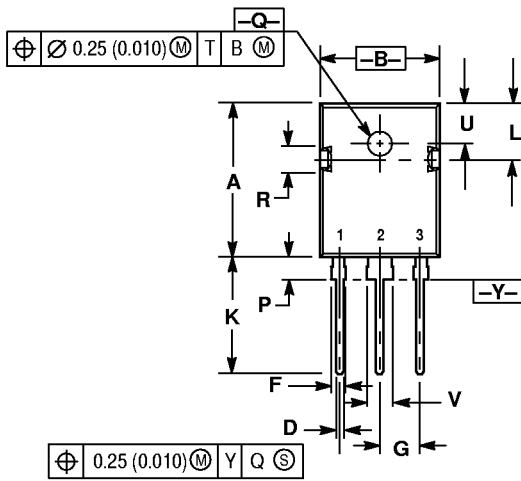

- NOTES:  
 1. DIMENSIONING AND TOLERANCING PER ANSI Y14.5M, 1982.  
 2. CONTROLLING DIMENSION: MILLIMETER.

DIM	MILLIMETERS		INCHES	
	MIN	MAX	MIN	MAX
A	20.40	20.90	0.803	0.823
B	15.44	15.95	0.608	0.628
C	4.70	5.21	0.185	0.205
D	1.09	1.30	0.043	0.051
E	1.50	1.63	0.059	0.064
F	1.80	2.18	0.071	0.086
G	5.45 BSC		0.215 BSC	
H	2.56	2.87	0.101	0.113
J	0.48	0.68	0.019	0.027
K	15.57	16.08	0.613	0.633
L	7.26	7.50	0.286	0.295
P	3.10	3.38	0.122	0.133
Q	3.50	3.70	0.138	0.145
R	3.30	3.80	0.130	0.150
U	5.30 BSC		0.209 BSC	
V	3.05	3.40	0.120	0.134

STYLE 3:  
 PIN 1. BASE  
 2. COLLECTOR  
 3. EMITTER  
 4. COLLECTOR

CASE 340F-03  
 TO-247AE  
 ISSUE E