

3N190 3N191

P-CHANNEL DUAL MOSFET ENHANCEMENT MODE

FEATURES	
DIRECT REPLACEMENT FOR INTERSIL 3N190 & 3N191	
LOW GATE LEAKAGE CURRENT	$I_{GSS} \leq \pm 10\text{pA}$
LOW TRANSFER CAPACITANCE	$C_{rss} \leq 1.0\text{pF}$
ABSOLUTE MAXIMUM RATINGS ¹	
@ 25 °C (unless otherwise stated)	
Maximum Temperatures	
Storage Temperature	-65 to +150 °C
Operating Junction Temperature	-55 to +135 °C
Maximum Power Dissipation	
Continuous Power Dissipation One Side	300mW
Continuous Power Dissipation Both Sides	525mW
Maximum Current	
Drain to Source ²	50mA
Maximum Voltages	
Drain to Gate ²	30V
Drain to Source ²	30V
Transient Gate to Source ^{2,3}	$\pm 125\text{V}$
Gate to Gate	$\pm 80\text{V}$

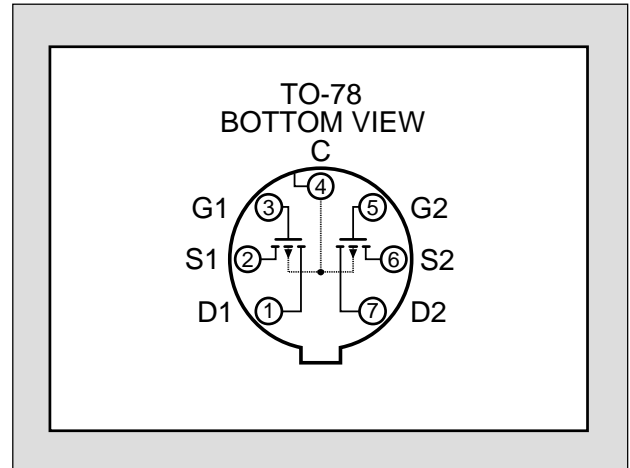

MATCHING CHARACTERISTICS @ 25 °C (unless otherwise stated) ($V_{BS} = 0\text{V}$ unless otherwise stated)

SYMBOL	CHARACTERISTIC	MIN	TYP	MAX	UNITS	CONDITIONS
g_{fs1}/g_{fs2}	Forward Transconductance Ratio	0.85		1.0		$V_{DS} = -15\text{V}$, $I_D = -500\mu\text{A}$, $f = 1\text{kHz}$
V_{GS1-2}	Gate to Source Threshold Voltage Differential			100	mV	$V_{DS} = -15\text{V}$, $I_D = -500\mu\text{A}$
$\frac{\Delta V_{GS1-2}}{\Delta T}$	Gate to Source Threshold Voltage Differential with Temperature ⁴			100	$\mu\text{V}/^\circ\text{C}$	$V_{DS} = -15\text{V}$, $I_D = -500\mu\text{A}$ $T_S = -55 \text{ TO } +25 \text{ }^\circ\text{C}$
$\frac{\Delta V_{GS1-2}}{\Delta T}$	Gate to Source Threshold Voltage Differential with Temperature ⁴			100		$V_{DS} = -15\text{V}$, $I_D = -500\mu\text{A}$ $T_S = +25 \text{ TO } +125 \text{ }^\circ\text{C}$

ELECTRICAL CHARACTERISTICS @ 25 °C (unless otherwise stated) ($V_{SB} = 0\text{V}$ unless otherwise stated)

SYMBOL	CHARACTERISTIC	MIN	TYP	MAX	UNITS	CONDITIONS
BV_{DSS}	Drain to Source Breakdown Voltage	-40			V	$I_D = -10\mu\text{A}$
BV_{SDS}	Source to Drain Breakdown Voltage	-40				$I_S = -10\mu\text{A}$, $V_{BD} = 0\text{V}$
V_{GS}	Gate to Source Voltage	-3.0		-6.5		$V_{DS} = -15\text{V}$, $I_D = -500\mu\text{A}$
$V_{GS(th)}$	Gate to Source Threshold Voltage	-2.0		-5.0		$V_{DS} = V_{GS}$, $I_D = -10\mu\text{A}$
I_{GSSR}	Reverse Gate Leakage Current			10	pA	$V_{GS} = 40\text{V}$
I_{GSSF}	Forward Gate Leakage Current			-10		$V_{GS} = -40\text{V}$
I_{DSS}	Drain Leakage Current "Off"			-200		$V_{DS} = -15\text{V}$
I_{SDS}	Source to Drain Leakage Current "Off"			-400		$V_{SD} = -15\text{V}$, $V_{DB} = 0\text{V}$
$I_{D(on)}$	Drain Current "On"	-5.0		-30.0		mA

ELECTRICAL CHARACTERISTICS CONT. @ 25 °C (unless otherwise stated) ($V_{SB} = 0V$ unless otherwise stated)

SYMBOL					
g_{fs}	Forward Transconductance ⁵	1500		4000	μS
Y_{os}	Output Admittance			300	
$r_{ds(on)}$	Drain to Source "On" Resistance			300	Ω
C_{rSS}	Reverse Transfer Capacitance			1.0	pF
C_{iSS}	Input Capacitance Output Shorted			4.5	
C_{oSS}	Output Capacitance Input Shorted			3.0	

$V_{DS} = -15V, I_D = -5mA, f = 1kHz$
 $V_{DS} = -20V, I_D = -100\mu A$
 $V_{DS} = -15V, I_D = -5mA, f = 1MHz$

SWITCHING CHARACTERISTICS

SYMBOL	CHARACTERISTIC	MIN	TYP	MAX	UNITS	CONDITIONS
$t_{d(on)}$	Turn On Delay Time			15	ns	$V_{DD} = -15V, I_{D(on)} = -5mA,$ $R_G = R_L = 1.4k\Omega$
t_r	Turn On Rise Time			30		
t_{off}	Turn Off Time			50		

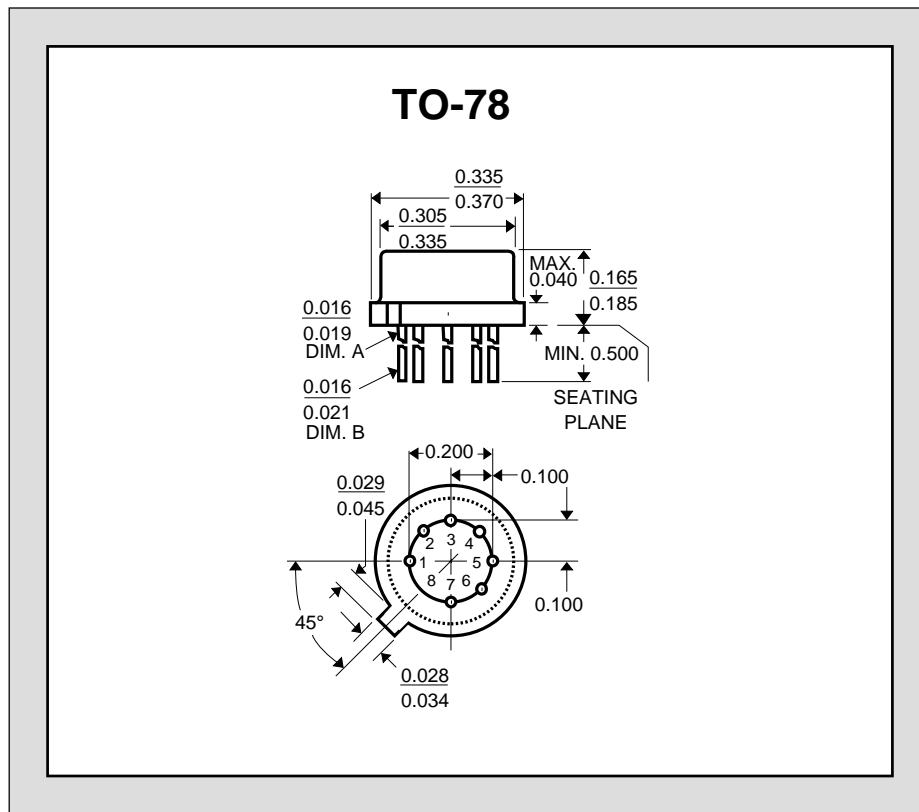

1. Absolute maximum ratings are limiting values above which serviceability may be impaired.
2. Per transistor.
3. Approximately doubles for every 10 °C increase in T_A .
4. Pulse: $t = 300\mu s$, Duty Cycle $\leq 3\%$
5. Measured at end points, T_A and T_B .

Information furnished by Linear Integrated Systems is believed to be accurate and reliable. However, no responsibility is assumed for its use; nor for any infringement of patents or other rights of third parties which may result from its use. No license is granted by implication or otherwise under any patent or patent rights of Linear Integrated Systems.



LittleDiode supplies new, hard to find or obsolete electronic components and semiconductors all over the world.

With over two million different components listed you are sure to find the part you need.

Feel free to visit us today at our online store:

LittleDiode.com

Looking forward to providing you with the best possible service.