

HIGH CURRENT NPN SILICON TRANSISTOR

- SGS-THOMSON PREFERRED SALESTYPE
- NPN TRANSISTOR

APPLICATIONS:

- MOTOR CONTROL
- HIGH FREQUENCY AND EFFICIENCY CONVERTERS

DESCRIPTION

High current, high speed transistor suited for power conversion applications, high efficiency converters and motor controls.

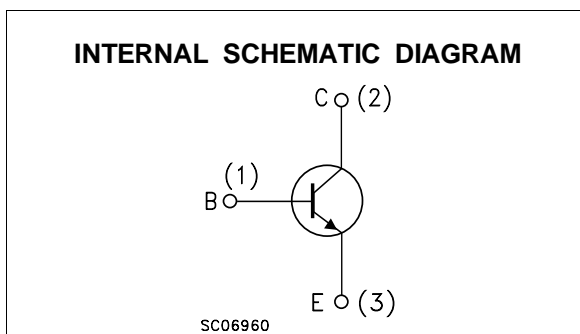
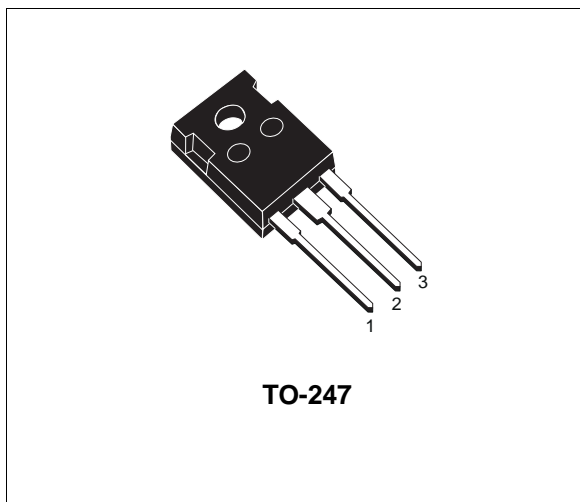

ABSOLUTE MAXIMUM RATINGS

Symbol	Parameter	Value	Unit
V_{CES}	Collector-Emitter Voltage ($V_{BE} = 0$)	500	V
V_{CEO}	Collector-Emitter Voltage ($I_B = 0$)	250	V
V_{EBO}	Emitter-Base Voltage ($I_C = 0$)	7	V
I_E	Emitter-Current	60	A
I_{EM}	Emitter Peak Current ($t_p < 5\text{ms}$)	70	A
I_B	Base Current	15	A
I_{BM}	Base Peak Current ($t_p < 5\text{ms}$)	18	A
P_{tot}	Total Dissipation at $T_c \leq 25^\circ\text{C}$	180	W
T_{stg}	Storage Temperature	-65 to 150	$^\circ\text{C}$
T_j	Max. Operating Junction Temperature	150	$^\circ\text{C}$

For PNP type voltage and current values are negative.

BUTW92

THERMAL DATA

R _{thj-case}	Thermal Resistance Junction-case	MAX	0.7	°C/W
-----------------------	----------------------------------	-----	-----	------

ELECTRICAL CHARACTERISTICS (T_{case} = 25 °C unless otherwise specified)

Symbol	Parameter	Test Conditions	Min.	Typ.	Max.	Unit
I _{CES}	Collector Cut-off Current (V _{BE} = -1.5V)	V _{CE} = 450 V V _{CE} = 450 V T _C = 100°C			50 1	μA mA
I _{EBO}	Emitter Cut-off Current (I _C = 0)	V _{EB} = 5 V			50	μA
V _{CES}	Collector-Emitter Breakdown Voltage (V _{EB} = 0)	I _C = 5 mA	500			V
V _{EBO}	Emitter-Base Breakdown Voltage (I _C = 0)	I _E = 50 mA	7			V
V _{CEO(sus)} *	Collector-Emitter Sustaining Voltage (I _B = 0)	I _C = 200 mA	250			V
V _{CE(sat)} *	Collector-Emitter Saturation Voltage	I _C = 60 A I _B = 15 A I _C = 60 A I _B = 15 A T _C = 100°C		0.8 1.1	1 1.5	V V
V _{BE(sat)} *	Base-Emitter Saturation Voltage	I _C = 60 A I _B = 15 A I _C = 60 A I _B = 15 A T _C = 100°C			1.9 2	V V
h _{FE} *	DC Current Gain	I _C = 60 A V _{CE} = 3 V I _C = 60 A V _{CE} = 3 V T _C = 100°C I _C = 5 A V _{CE} = 3 V	9 6		65	
t _s t _f	RESISTIVE LOAD Storage Time Fall Time	I _C = 50 A V _{CC} = 250 V I _{B1} = -I _{B2} = 10 A		1.2 250	1.4 300	μs ns

* Pulsed: Pulse duration = 300 μs, duty cycle 1.5 %

TO-247 MECHANICAL DATA

DIM.	mm			inch		
	MIN.	TYP.	MAX.	MIN.	TYP.	MAX.
A	4.7		5.3	0.185		0.209
D	2.2		2.6	0.087		0.102
E	0.4		0.8	0.016		0.031
F	1		1.4	0.039		0.055
F3	2		2.4	0.079		0.094
F4	3		3.4	0.118		0.134
G		10.9			0.429	
H	15.3		15.9	0.602		0.626
L	19.7		20.3	0.776		0.779
L3	14.2		14.8	0.559	0.413	0.582
L4		34.6			1.362	
L5		5.5			0.217	
M	2		3	0.079		0.118
Dia	3.55		3.65	0.140		0.144

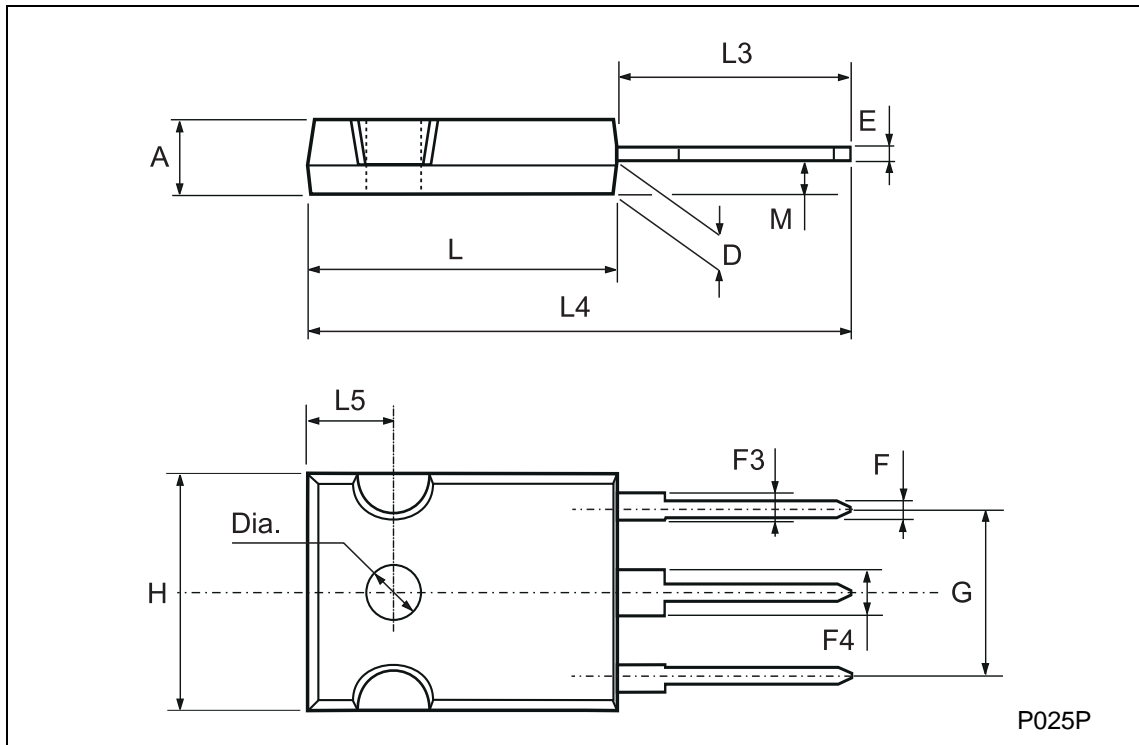

Information furnished is believed to be accurate and reliable. However, SGS-THOMSON Microelectronics assumes no responsibility for the consequences of use of such information nor for any infringement of patents or other rights of third parties which may result from its use. No license is granted by implication or otherwise under any patent or patent rights of SGS-THOMSON Microelectronics. Specifications mentioned in this publication are subject to change without notice. This publication supersedes and replaces all information previously supplied. SGS-THOMSON Microelectronics products are not authorized for use as critical components in life support devices or systems without express written approval of SGS-THOMSON Microelectronics.

© 1997 SGS-THOMSON Microelectronics - Printed in Italy - All Rights Reserved

SGS-THOMSON Microelectronics GROUP OF COMPANIES

Australia - Brazil - Canada - China - France - Germany - Italy - Japan - Korea - Malaysia - Malta - Morocco - The Netherlands -
Singapore - Spain - Sweden - Switzerland - Taiwan - Thailand - United Kingdom - U.S.A

...



LittleDiode supplies new, hard to find or obsolete electronic components and semiconductors all over the world.

With over two million different components listed you are sure to find the part you need.

Feel free to visit us today at our online store:

LittleDiode.com

Looking forward to providing you with the best possible service.