

LINEAR SYSTEMS

Linear Integrated Systems

3N163, 3N164

P-CHANNEL ENHANCEMENT MODE
MOSFET

FEATURES	
VERY HIGH INPUT IMPEDANCE	
HIGH GATE BREAKDOWN	
ULTRA LOW LEAKAGE	
FAST SWITCHING	
LOW CAPACITANCE	
ABSOLUTE MAXIMUM RATINGS (NOTE 1)	
@ 25°C (unless otherwise noted)	
Drain-Source or Drain-Gate Voltage	
3N163	-40V
3N164	-30V
Transient G-S Voltage (NOTE 1)	±125V
Drain Current	50mA
Storage Temperature	-65°C to +200°C
Power Dissipation	375mW

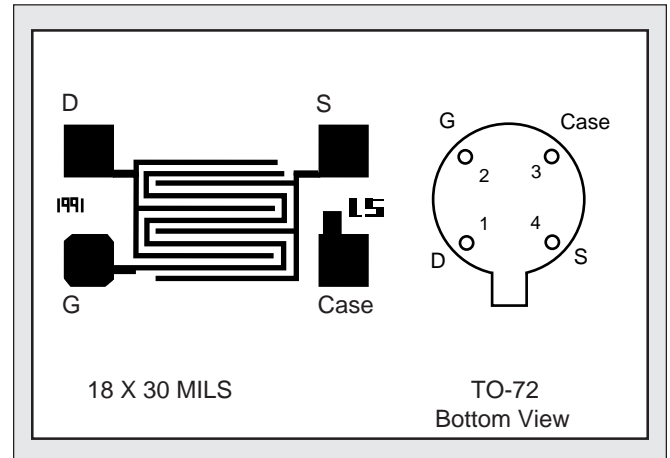

ELECTRICAL CHARACTERISTICS @ 25°C (unless otherwise noted)

SYMBOL	CHARACTERISTICS	3N163		3N164		UNITS	CONDITIONS
		MIN	MAX	MIN	MAX		
I_{GSSF}	Gate Forward Current	-10		-10		pA	$V_{GS} = -40V$ $V_{DS} = 0$ (3N163) $V_{GS} = -30V$ $V_{DS} = 0$ (3N164)
	$T_A = +125^\circ C$		-25		-25		
BV_{DSS}	Drain-Source Breakdown Voltage	-40		-30		V	$I_D = -10\mu A$ $V_{GS} = 0$ $I_S = -10\mu A$ $V_{GD} = 0$ $V_{BD} = 0$
BV_{SDS}	Source-Drain Breakdown Voltage	-40		-30			
$V_{GS(th)}$	Threshold Voltage	-2.0	-5.0	-2.0	-5.0	pA	$V_{DS} = V_{GS}$ $I_D = -10\mu A$ $V_{DS} = -15V$ $I_D = -10\mu A$
$V_{GS(th)}$	Threshold Voltage	-2.0	-5.0	-2.0	-5.0		
V_{GS}	Gate Source Voltage	-3.0	-6.5	-3.0	-6.5	pA	$V_{DS} = -15V$ $I_D = -0.5mA$ $V_{DS} = -15V$ $V_{GS} = 0$
I_{DSS}	Zero Gate Voltage Drain Current		200		400		
I_{SDS}	Source Drain Current		400		800	ohms	$V_{DS} = 15V$ $V_{GS} = V_{DB} = 0$ $V_{GS} = -20V$ $I_D = -100\mu A$
$r_{DS(on)}$	Drain-Source on Resistance		250		300		
$I_{D(on)}$	On Drain Current	-5.0	-30	-3.0	-30	mA	$V_{DS} = -15V$ $V_{GS} = -10V$ $V_{DS} = -15V$ $I_D = -10mA$ $f = 1kHz$
g_{fs}	Forward Transconductance	2000	4000	1000	4000		
g_{os}	Output Admittance		250		250	pF	$V_{DS} = -15V$ $I_D = -10mA$ $f = 1MHz$ (NOTE 2)
C_{iss}	Input Capacitance-Output Shorted		2.5		2.5		
C_{rss}	Reverse Transfer Capacitance		0.7		0.7		
C_{oss}	Output Capacitance Input Shorted		3.0		3.0		

Linear Integrated Systems

4042 Clipper Ct., Fremont, CA 94538 TEL: (510) 490-9160 • FAX: (510) 353-0261

SWITCHING CHARACTERISTICS $T_A=25^\circ\text{C}$ and $V_{BS}=0$ unless otherwise noted)

SYMBOL	CHARACTERISTICS	3N163		3N164		UNITS	CONDITIONS
		MIN	MAX	MIN	MAX		
t_{on}	Turn-On Delay Time		12		12	ns	$V_{DD}=-15\text{V}$ $I_{D(on)}=-10\text{mA}$ (NOTE 2) $R_G=R_L=1.4\text{K}\Omega$
t_r	Rise Time		24		24		
t_{off}	Turn-Off Time		50		50		

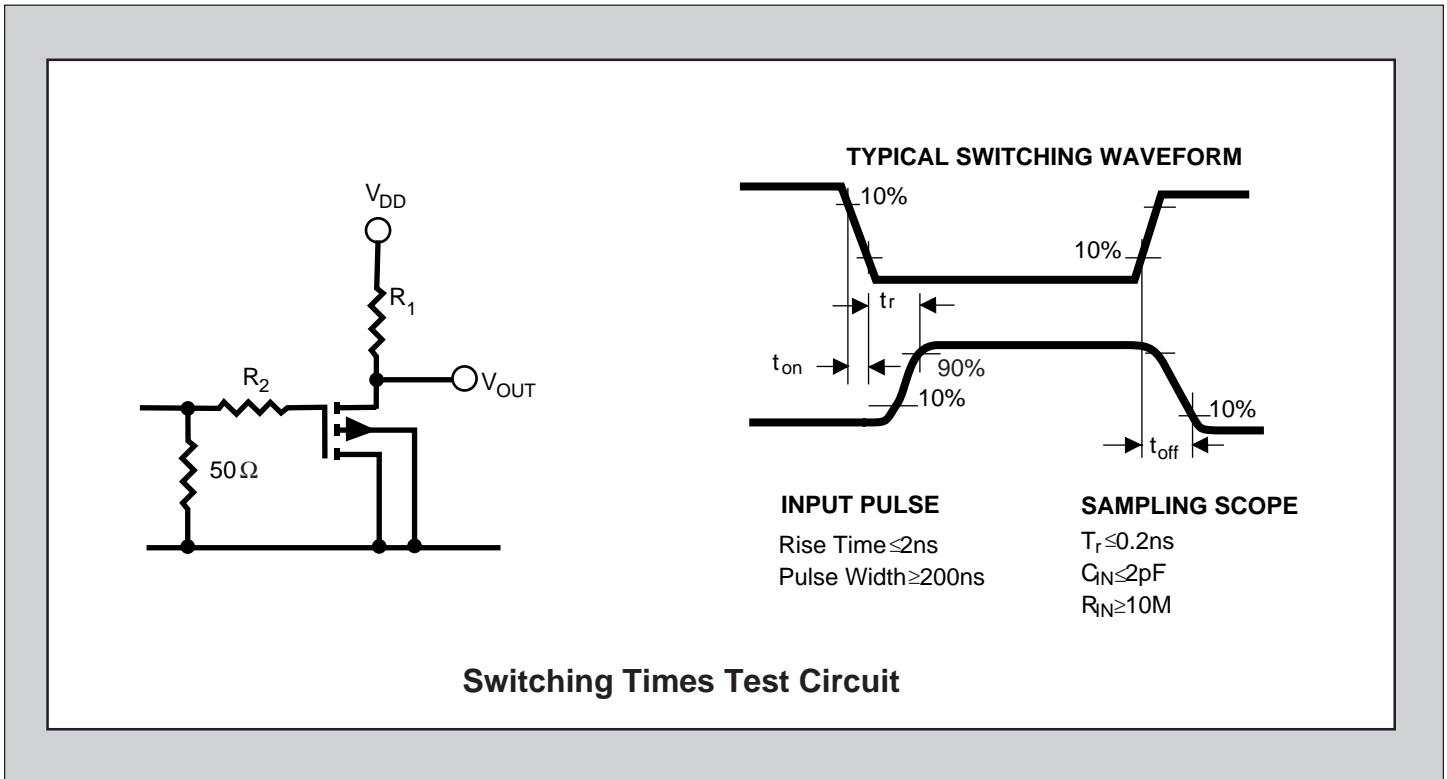

NOTES:

1. Devices must not be tested at $\pm 125\text{V}$ more than once, nor for longer than 300ms.
2. For design reference only, not 100% tested.

Stresses above those listed under "Absolute Maximum Ratings" may cause permanent damage to the device. These are stress ratings only and functional operation of the device at these or any other conditions above those indicated in the operational sections of the specifications is not implied. Exposure to absolute maximum rating conditions for extended periods may affect device reliability.



LittleDiode supplies new, hard to find or obsolete electronic components and semiconductors all over the world.

With over two million different components listed you are sure to find the part you need.

Feel free to visit us today at our online store:

LittleDiode.com

Looking forward to providing you with the best possible service.