

## N-CHANNEL POWER MOSFETS

### IRF230/231/232/233

#### FEATURES

- Low  $R_{DS(on)}$
- Improved inductive ruggedness
- Fast switching times
- Rugged polysilicon gate cell structure
- Low input capacitance
- Extended safe operating area
- Improved high temperature reliability
- TO-3 package (Standard)

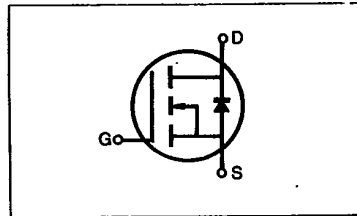
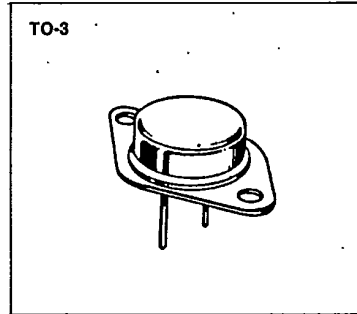

#### PRODUCT SUMMARY

Part Number	$V_{DS}$	$R_{DS(on)}$	$I_D$
IRF230	200V	0.4 $\Omega$	9.0A
IRF231	150V	0.4 $\Omega$	9.0A
IRF232	200V	0.6 $\Omega$	8.0A
IRF233	150V	0.6 $\Omega$	8.0A

#### MAXIMUM RATINGS

Characteristic	Symbol	IRF230	IRF231	IRF232	IRF233	Unit
Drain-Source Voltage (1)	$V_{DSS}$	200	150	200	150	Vdc
Drain-Gate Voltage ( $R_{GS}=1.0M\Omega$ ) (1)	$V_{DGR}$	200	150	200	150	Vdc
Gate-Source Voltage	$V_{GS}$	$\pm 20$				Vdc
Continuous Drain Current $T_C=25^\circ C$	$I_D$	9.0	9.0	8.0	8.0	Adc
Continuous Drain Current $T_C=100^\circ C$	$I_D$	6.0	6.0	5.0	5.0	Adc
Drain Current—Pulsed (3)	$I_{DM}$	36	36	32	32	Adc
Gate Current—Pulsed	$I_{GM}$	$\pm 1.5$				Adc
Total Power Dissipation @ $T_C=25^\circ C$ Derate above $25^\circ C$	$P_D$	75 0.6				Watts W/ $^\circ C$
Operating and Storage Junction Temperature Range	$T_J, T_{stg}$	-55 to 150				$^\circ C$
Maximum Lead Temp. for Soldering Purposes, 1/8" from case for 5 seconds	$T_L$	300				$^\circ C$

Notes: (1)  $T_J=25^\circ C$  to  $150^\circ C$

(2) Pulse test: Pulse width  $\leq 300\mu s$ , Duty Cycle  $\leq 2\%$

(3) Repetitive rating: Pulse width limited by max. junction temperature

**IRF230/231/232/233****ELECTRICAL CHARACTERISTICS** ( $T_C=25^\circ\text{C}$  unless otherwise specified)

Characteristic	Symbol	Type	Min	Typ	Max	Units	Test Conditions
Drain-Source Breakdown Voltage	$BV_{DSS}$	IRF230	200	—	—	V	$V_{GS}=0V$
		IRF232	—	—	—	—	
		IRF231 IRF233	150	—	—	—	V
Gate Threshold Voltage	$V_{GS(th)}$	ALL	2.0	—	4.0	V	$V_{DS}=V_{GS}$ , $I_D=250\mu A$
Gate-Source Leakage Forward	$I_{GSS}$	ALL	—	—	100	nA	$V_{GS}=20V$
Gate-Source Leakage Reverse	$I_{GSS}$	ALL	—	—	-100	nA	$V_{GS}=-20V$
Zero Gate Voltage Drain Current	$I_{DSS}$	ALL	—	—	250	$\mu A$	$V_{DS}=\text{Max. Rating}$ , $V_{GS}=0V$
			—	—	1000	$\mu A$	$V_{DS}=\text{Max. Rating} \times 0.8$ , $V_{GS}=0V$ , $T_C=125^\circ\text{C}$
On-State Drain-Source Current (2)	$I_{D(on)}$	IRF230	9.0	—	—	A	$V_{DS} > I_{D(on)} \times R_{DS(on) \text{ max.}}$ , $V_{GS}=10V$
		IRF231	—	—	—	—	
		IRF232 IRF233	8.0	—	—	—	
Static Drain-Source On-State Resistance (2)	$R_{DS(on)}$	IRF230	—	0.25	0.4	$\Omega$	$V_{GS}=10V$ , $I_D=5.0A$
		IRF231	—	—	—	—	
		IRF232 IRF233	—	0.4	0.6	$\Omega$	
Forward Transconductance (2)	$g_{fs}$	ALL	3.0	4.6	—	$\Omega$	$V_{DS} > I_{D(on)} \times R_{DS(on) \text{ max.}}$ , $I_D=5.0A$
Input Capacitance	$C_{iss}$	ALL	—	720	800	pF	$V_{GS}=0V$ , $V_{DS}=25V$ , $f=1.0\text{MHz}$
Output Capacitance	$C_{oss}$	ALL	—	250	450	pF	
Reverse Transfer Capacitance	$C_{rss}$	ALL	—	60	150	pF	
Turn-On Delay Time	$t_{d(on)}$	ALL	—	—	30	ns	$V_{DD}=0.5BV_{DSS}$ , $I_D=5.0A$ , $Z_\theta=15\Omega$ (MOSFET switching times are essentially independent of operating temperature.)
Rise Time	$t_r$	ALL	—	—	50	ns	
Turn-Off Delay Time	$t_{d(off)}$	ALL	—	—	50	ns	
Fall Time	$t_f$	ALL	—	—	40	ns	
Total Gate Charge (Gate-Source Plus Gate-Drain)	$Q_g$	ALL	—	19	30	nC	$V_{GS}=10V$ , $I_D=12A$ , $V_{DS}=0.8 \text{ Max. Rating}$ (Gate charge is essentially independent of operating temperature.)
Gate-Source Charge	$Q_{gs}$	ALL	—	5.0	—	nC	
Gate-Drain ("Miller") Charge	$Q_{gd}$	ALL	—	14	—	nC	

**THERMAL RESISTANCE**

Junction-to-Case	$R_{thJC}$	ALL	—	—	1.67	K/W	
Case-to-Sink	$R_{thCS}$	ALL	—	0.1	—	K/W	Mounting surface flat, smooth, and greased
Junction-to-Ambient	$R_{thJA}$	ALL	—	—	30	K/W	Free Air Operation

Notes: (1)  $T_J=25^\circ\text{C}$  to  $150^\circ\text{C}$ (2) Pulse test: Pulse width  $\leq 300\mu s$ , Duty Cycle  $\leq 2\%$ 

(3) Repetitive rating: Pulse width limited by max. junction temperature



**IRF230/231/232/233**

**N-CHANNEL  
POWER MOSFETS**

**SOURCE-DRAIN DIODE RATINGS AND CHARACTERISTICS**

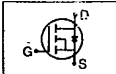
Characteristic	Symbol	Type	Min	Typ	Max	Units	Test Conditions
Continuous Source Current (Body Diode)	$I_S$	IRF230	—	—	9.0	A	Modified MOSFET symbol showing the integral reverse P-N junction rectifier 
		IRF231	—	—	8.0	A	
		IRF232 IRF233	—	—	8.0	A	
Pulse Source Current (Body Diode) (3)	$I_{SM}$	IRF230	—	—	36	A	
		IRF231	—	—	32	A	
		IRF232 IRF233	—	—	32	A	
Diode Forward Voltage (2)	$V_{SD}$	IRF230	—	—	2.0	V	$T_C=25^\circ\text{C}$ , $I_S=9.0\text{A}$ , $V_{GS}=0\text{V}$
		IRF231	—	—	2.0	V	$T_C=25^\circ\text{C}$ , $I_S=8.0\text{A}$ , $V_{GS}=0\text{V}$
		IRF232 IRF233	—	—	1.8	V	$T_C=25^\circ\text{C}$ , $I_S=8.0\text{A}$ , $V_{GS}=0\text{V}$
Reverse Recovery Time	$t_{rr}$	ALL	—	450	—	ns	$T_J=150^\circ\text{C}$ , $I_F=9.0\text{A}$ , $di/dt=100\text{A}/\mu\text{s}$

Notes: (1)  $T_J=25^\circ\text{C}$  to  $150^\circ\text{C}$  (2) Pulse test: Pulse width  $\leq 300\mu\text{s}$ , Duty Cycle  $\leq 2\%$   
 (3) Repetitive rating: Pulse width limited by max. junction temperature

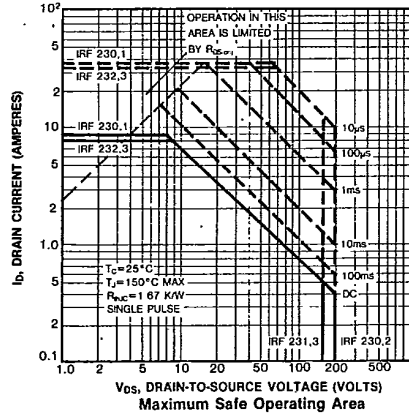
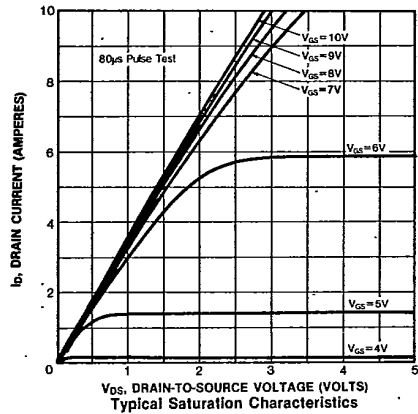
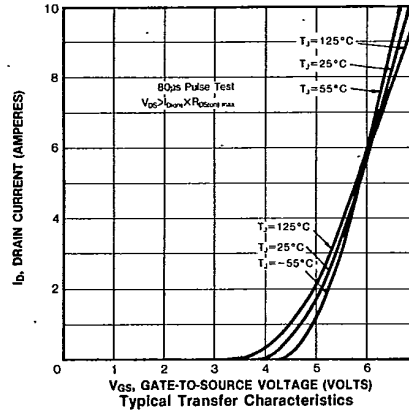
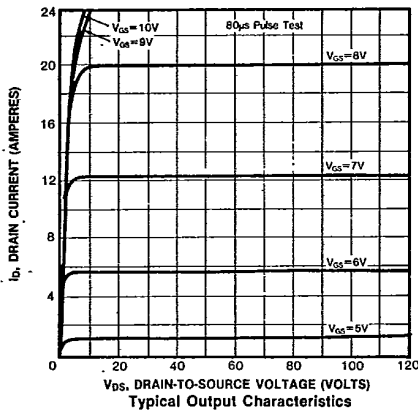

**IRF230/231/232/233**

**N-CHANNEL  
POWER MOSFETS**

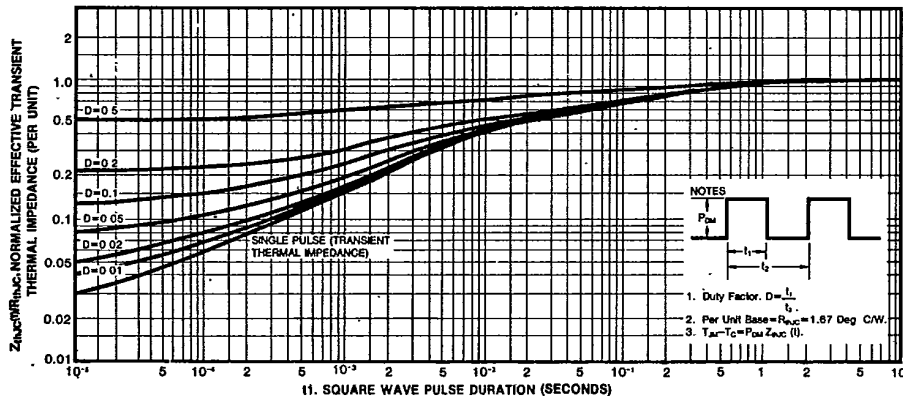

11. SQUARE WAVE PULSE DURATION (SECONDS)  
Maximum Effective Transient Thermal Impedance Junction-to-Case Vs. Pulse Duration

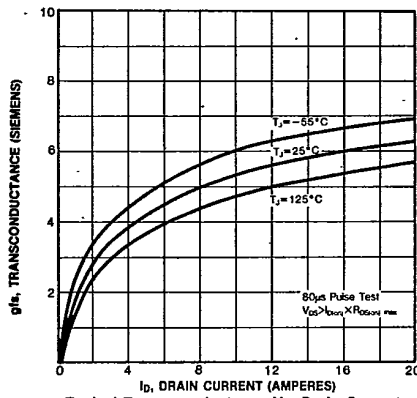

Typical Transconductance Vs. Drain Current

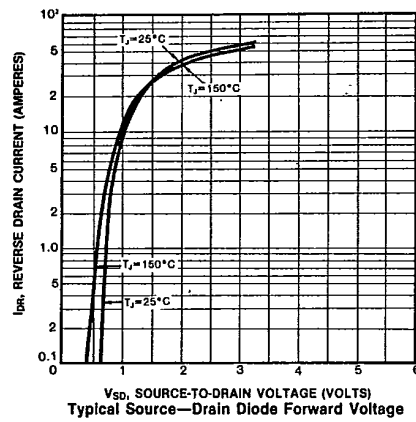

Typical Source-Drain Diode Forward Voltage

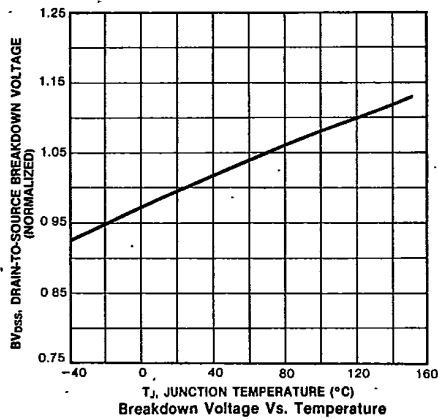

Breakdown Voltage Vs. Temperature

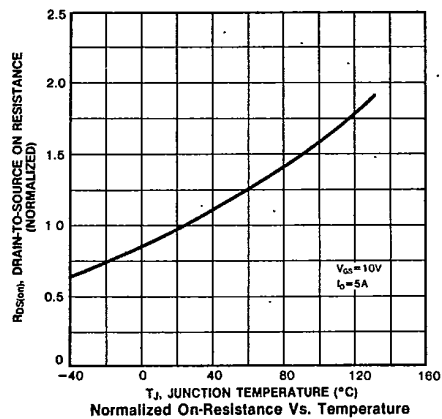

Normalized On-Resistance Vs. Temperature

**IRF230/231/232/233**

**N-CHANNEL  
POWER MOSFETS**

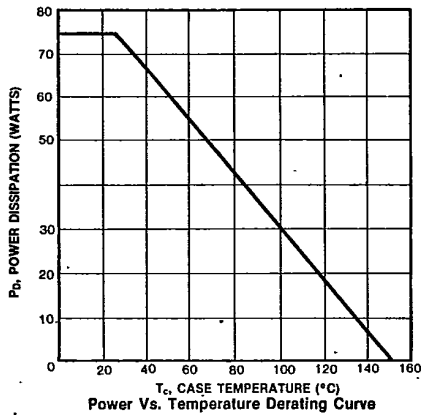
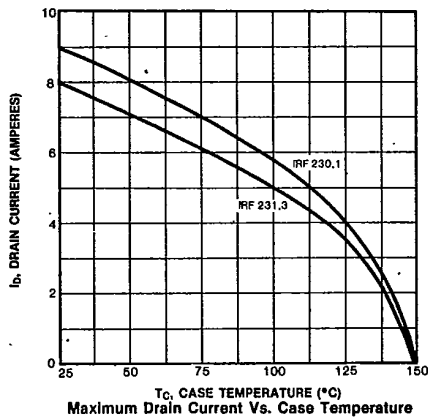
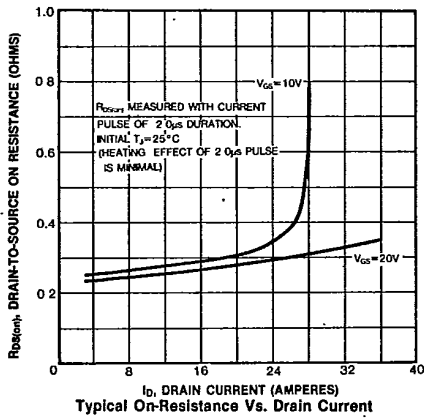
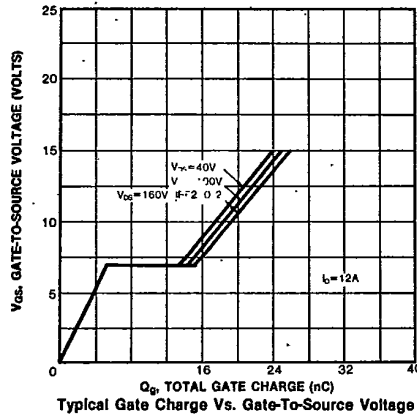
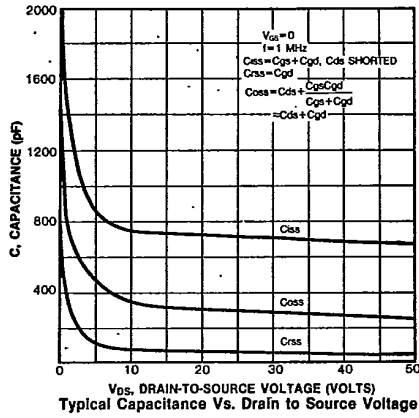

This datasheet has been downloaded from:

[www.DatasheetCatalog.com](http://www.DatasheetCatalog.com)

Datasheets for electronic components.



LittleDiode supplies new, hard to find or obsolete electronic components and semiconductors all over the world.

With over two million different components listed you are sure to find the part you need.

Feel free to visit us today at our online store:

[LittleDiode.com](http://LittleDiode.com)

Looking forward to providing you with the best possible service.