

MODEL 1220 FLUSH MOUNT, ISO-TECHNOLOGY OEM STYLE PRESSURE TRANSDUCER

DESCRIPTION

The Model 1220 Transducer is an OEM style, flush mount, pressure transducer which offers 0 to 100 mV output and is designed to be easily adapted by a customer with unique packaging requirements. It offers very reliable, consistent long term performance.

The sensor is a solid-state piezoresistive element which provides excellent stability and typical repeatabilities of $\pm 0.02\%$.

Using ISO-Technology design, the silicon sensor is protected from the process by a stainless steel media dia-

phragm. All media wetted parts are AISI Type 316L stainless steel (316L ss).

FEATURES

- 3-year warranty
- Fully compensated and calibrated
- All 316L ss media wetted materials
- Compact package size

Foxboro/ICT

© 1988 by The Foxboro Company

FOXBORO®

®Registered Trademark

TYPICAL APPLICATIONS

- Industrial control
- Infusion Pumps
- Diagnostics
- Refrigeration
- Environmental controls
- Pollution control

PERFORMANCE SPECIFICATIONS

Accuracy (Includes linearity, hysteresis, and repeatability. See Reference Conditions)

Standard Performance (Max) $\pm 0.50\%$ of span-Terminal Based ($\pm 0.25\%$ of span BFSL)

Enhanced Performance (Max) $\pm 0.25\%$ of span-Terminal Based ($\pm 0.13\%$ of span BFSL)

Operating Temperature Range

Media Temperature

-40 to +121°C (-40 to +250°F)

Ambient Temperature

-40 to +121°C (-40 to +250°F)

Compensated Temperature Range

-28 to +82°C (-20 to +180°F)

Temperature Performance (over compensated range)

Standard Performance (Max)

Zero Error $\pm 0.0224\%/^{\circ}\text{C}$ ($\pm 0.0125\%/^{\circ}\text{F}$)

Span Error $\pm 0.0224\%/^{\circ}\text{C}$ ($\pm 0.0125\%/^{\circ}\text{F}$)

Enhanced Performance (Max)

Zero Error $\pm 0.0112\%/^{\circ}\text{C}$ ($\pm 0.0063\%/^{\circ}\text{F}$)

Span Error $\pm 0.0112\%/^{\circ}\text{C}$ ($\pm 0.0063\%/^{\circ}\text{F}$)

Repeatability $\pm 0.02\%$ of span

Drift Less than $\pm 0.3\%$ of span over a six month period.

RFI Effects Typically less than 1% from 27 to 500 MHz for 5 V/m field intensity 1 m from the device.

Overrange Effect Zero shift is less than $\pm 0.05\%$ of span after applying two times upper-range value or 7500 psi (whichever is less).

Position Effect The output changes less than 0.05% of span for a 90° tilt in any direction.

Vibration Effect The total effect (maximum effect at any point on the scale) at frequencies up to 200 Hz and amplitudes up to 6 mm (0.25 in) peak-to-peak or for accelerations up to 30 m/s² (3 "g"), whichever is smaller, is less than 0.1% of span.

Calibration Fixed range. Zero is calibrated to within ± 2 mV. Full scale is calibrated to true full scale within ± 2 mV.

REFERENCE CONDITIONS

Media Temperature 24 $\pm 2^{\circ}\text{C}$ (75 $\pm 4^{\circ}\text{F}$)

Ambient Temperature 24 $\pm 2^{\circ}\text{C}$ (75 $\pm 4^{\circ}\text{F}$)

Vibration (in any plane) 1 m/s² (0.1 "g") maximum

Relative Humidity 50 $\pm 10\%$

Ambient Pressure 860 to 1060 mbar

Supply Voltage 10.000 ± 0.001 V or 1.5 ± 0.00015 mA, as applicable

PHYSICAL SPECIFICATIONS

Pressure Connections Flush diaphragm

Overrange Protection Will withstand pressure over-ranges up to two times upper-range value or 7500 psi (whichever is less) with negligible change in output.

Material of Media Wetted Parts 316L ss

Fill Fluid Dimethylsiloxane (DC-200). Less than 0.1 cc required.

Mass 22.5 g (0.8 oz)

ELECTRICAL SPECIFICATIONS

Input Excitation

Voltage Input 10.00 ± 0.01 V (at 0.3 mA typ)
Current Input 1.500 ± 0.0015 mA (at 6 V typ)

Excitation Limits

Voltage Input 21.2 V max
Current Input Increased input not recommended.

Output (for zero pressure input) 0.0 ± 2 mV

Output Span (for 0 to 100% input pressure change)
 100 ± 2 mV

Output Common Mode Voltage

Voltage Input 0.4 V typ
Current Input 2 V typ

Input Impedance

Voltage Input 30 000 ohms typ; 20 000 ohms min;
 45 000 ohms max
Current Input 4000 ohms typ; 2000 ohms min;
 6000 ohms max

Output Impedance 4500 ohms typ; 3500 ohms min;
 6000 ohms max

Effect on Excitation Change Output is ratiometric to input excitation.

Response Time When excited by an 80% (10% to 90%) input pressure change, the maximum time for the output to reach 90% of the final steady-state value is 100 microseconds.

Isolation Voltage 500 V dc or ac rms between the case and any input or output electrical connection will not cause damage.

Electrical Connections

Standard Four 0.025-inch square leads, 0.32-inch long, 0.10-inch spacing between leads.
Optional Berg pin style mating connector with 6-inch, 22 gauge wires.

MODEL CODE

PRESSURE RANGES		COMPENSATION	
-05 = 0 to 25 psig/psia ^(a)	-16 = 0 to 2000 psig	-L = Laser trimmed compensation board attached	
-07 = 0 to 30 psig/psia	-17 = 0 to 3000 psig	-M = Laser trimmed compensation board unattached	
-08 = 0 to 50 psig/psia	-18 = 0 to 5000 psig ^(b)	OPTION/ACCESSORIES (Add only if desired)	
-09 = 0 to 100 psig/psia		-A = Enhanced accuracy and temperature performance.	
-10 = 0 to 150 psig/psia		-C = Mating connector with leads ^(c)	
-11 = 0 to 250 psig/psia			
-12 = 0 to 300 psig/psia			
-13 = 0 to 500 psig/psia			
-14 = 0 to 1000 psig/psia			
-15 = 0 to 1500 psig			
TYPE		ORDER CODE	
-G = Gauge Pressure		MODEL 1220	
-A = Absolute Pressure		Pressure Range	
POWER SUPPLY		Type	
-K = 10 V excitation		Power Supply	
-L = 1.5 mA excitation		Pressure Connection	
PRESSURE CONNECTION		Compensation	
-6 = Flush mount		Option/Accessories	

^(a)For ranges below 25 psig/psia, consult factory

^(b)Consult factory

^(c)For evaluation units, -C mating connector (Option/Accessories) should be purchased for wiring convenience

WIRING

Standard Electrical Connection

Pin	Signal
A	-OUTPUT
B	+ INPUT
C	+ OUTPUT
D	-INPUT

Optional Mating Connector Leads

Wire Color	Signal
Red	+ INPUT
Black	-INPUT
Green	+ OUTPUT
White	-OUTPUT

Leads are 22 gauge, 6-inches long

3-YEAR WARRANTY

Foxboro warrants the original purchaser that Foxboro-manufactured Model 1220 Transducers shall be free from defects in material and workmanship and agrees to either replace or repair free of charge, any such transducer which shall be returned to the factory within three (3) years from date of delivery, transportation charges prepaid by purchaser. Purchaser retains responsibility for application, corrosion resistance, and functional adequacy of transducer.

DIMENSIONS—NOMINAL

mm
in

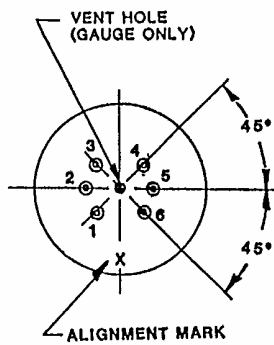
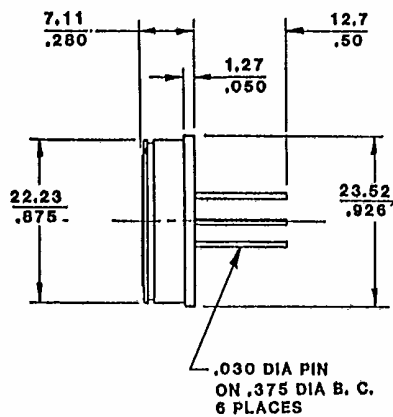

(COMPENSATION BOARD
PROVIDED UNATTACHED)

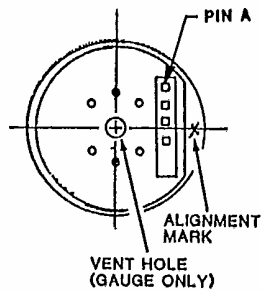
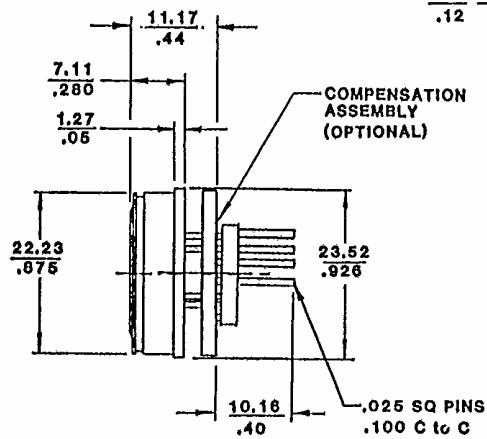
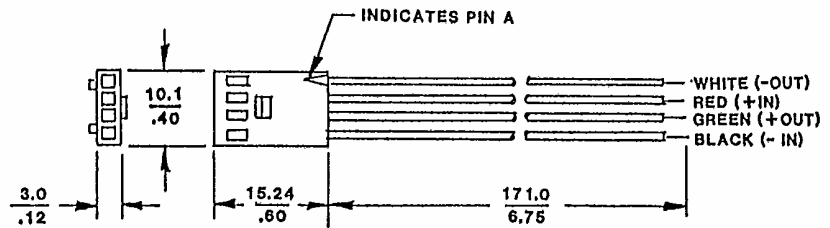

Foxboro/ICT
A Division of The Foxboro Company
199 Riveroaks Parkway
San Jose, CA 95134
Telephone 408-946-9630

NOTE:
Mating connector compatible with compensation
assembly only.

This datasheet has been downloaded from:

www.DatasheetCatalog.com

Datasheets for electronic components.



LittleDiode supplies new, hard to find or obsolete electronic components and semiconductors all over the world.

With over two million different components listed you are sure to find the part you need.

Feel free to visit us today at our online store:

LittleDiode.com

Looking forward to providing you with the best possible service.