

## NPN HIGH POWER SILICON TRANSISTOR

Qualified per MIL-PRF-19500/371

### Devices

2N3902

2N5157

### Qualified Level

JAN  
JANTX

### MAXIMUM RATINGS

| Ratings                               | Symbol         | 2N3902                                | 2N5157 | Unit        |
|---------------------------------------|----------------|---------------------------------------|--------|-------------|
| Collector-Emitter Voltage             | $V_{CEO}$      | 400                                   | 500    | Vdc         |
| Emitter-Base Voltage                  | $V_{EBO}$      | 5.0                                   | 6.0    | Vdc         |
| Collector-Base Voltage                | $V_{CBO}$      | 700                                   |        | Vdc         |
| Base Current                          | $I_B$          | 2.0                                   |        | Adc         |
| Collector Current                     | $I_C$          | 3.5                                   |        | Adc         |
| Total Power Dissipation               | $P_T$          | @ $T_A = +25^{\circ}C$ <sup>(1)</sup> | 5.0    | W           |
|                                       |                | @ $T_C = +75^{\circ}C$ <sup>(2)</sup> | 100    | W           |
| Operating & Storage Temperature Range | $T_j, T_{stg}$ | -65 to +200                           |        | $^{\circ}C$ |

### THERMAL CHARACTERISTICS

| Characteristics                      | Symbol          | Max. | Unit          |
|--------------------------------------|-----------------|------|---------------|
| Thermal Resistance, Junction-to-Case | $R_{\theta JC}$ | 1.25 | $^{\circ}C/W$ |

1) Derate linearly 29 mW/ $^{\circ}C$  for  $T_A > +25^{\circ}C$

2) Derate linearly 0.8 W/ $^{\circ}C$  for  $T_C > +75^{\circ}C$

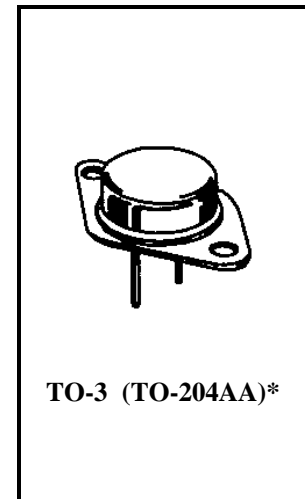

\*See Appendix A for Package Outline

### ELECTRICAL CHARACTERISTICS

| Characteristics | Symbol | Min. | Max. | Unit |
|-----------------|--------|------|------|------|
|-----------------|--------|------|------|------|

### OFF CHARACTERISTICS

|  |                  |           |            |           |
|--|------------------|-----------|------------|-----------|
| Collector-Emitter Cutoff Current<br>$V_{CE} = 325$ Vdc<br>$V_{CE} = 400$ Vdc | 2N3902<br>2N5157 | $I_{CEO}$ | 250<br>250 | $\mu$ Adc |
| Collector-Emitter Cutoff Current<br>$V_{BE} = 1.5$ Vdc; $V_{CE} = 700$ Vdc   |                  | $I_{CEX}$ | 500        | $\mu$ Adc |
| Emitter-Base Cutoff Current<br>$V_{EB} = 5.0$ Vdc<br>$V_{EB} = 6.0$ Vdc      | 2N3902<br>2N5157 | $I_{EBO}$ | 200<br>200 | $\mu$ Adc |

### ON CHARACTERISTICS<sup>(3)</sup>

|  |  |               |            |     |
|--|--|---------------|------------|-----|
| Base-Emitter Saturation Voltage<br>$I_C = 1.0$ Adc; $I_B = 0.1$ Adc<br>$I_C = 3.5$ Adc; $I_B = 0.7$ Adc      |  | $V_{BE(sat)}$ | 1.5<br>2.0 | Vdc |
| Collector-Emitter Saturation Voltage<br>$I_C = 1.0$ Adc; $I_B = 0.1$ Adc<br>$I_C = 3.5$ Adc; $I_B = 0.7$ Adc |  | $V_{CE(sat)}$ | 0.8<br>2.5 | Vdc |

**2N3902, 2N5157 JAN SERIES**

**ELECTRICAL CHARACTERISTICS (con't)**

| Characteristics  | Symbol                | Min.                | Max. | Unit |
|--|-----------------------|---------------------|------|------|
| <b>ON CHARACTERISTICS<sup>(3)</sup> (con't)</b>  |                       |                     |      |      |
| Forward-Current Transfer Ratio<br>I <sub>C</sub> = 0.5 Adc; V <sub>CE</sub> = 5.0 Vdc<br>I <sub>C</sub> = 1.0 Adc; V <sub>CE</sub> = 5.0 Vdc<br>I <sub>C</sub> = 2.5 Adc; V <sub>CE</sub> = 5.0 Vdc<br>I <sub>C</sub> = 3.5 Adc; V <sub>CE</sub> = 5.0 Vdc | h <sub>FE</sub>       | 25<br>30<br>10<br>5 | 90   |      |
| Collector-Emitter Sustaining Voltage<br>I <sub>C</sub> = 100 mAdc  | V <sub>CEO(sus)</sub> | 325<br>400          |      | Vdc  |

**DYNAMIC CHARACTERISTICS**

|  |                  |     |     |    |
|--|------------------|-----|-----|----|
| Small-Signal Short-Circuit Forward Current Transfer Ratio<br>I <sub>C</sub> = 0.2 Adc; V <sub>CE</sub> = 10 Vdc, f = 1 MHz | h <sub>fe</sub>  | 2.5 | 25  |    |
| Output Capacitance<br>V <sub>CB</sub> = 10 Vdc; I <sub>E</sub> = 0, 100 kHz ≤ f ≤ 1.0 MHz                                  | C <sub>obo</sub> |     | 250 | pF |

**SWITCHING CHARACTERISTICS**

|  |                  |  |     |    |
|--|------------------|--|-----|----|
| Turn-On Time<br>V <sub>CC</sub> = 125 Vdc; I <sub>C</sub> = 1.0 Adc; I <sub>B1</sub> = 0.1 Adc                               | t <sub>on</sub>  |  | 0.8 | μs |
| Turn-Off Time<br>V <sub>CC</sub> = 125 Vdc; I <sub>C</sub> = 1.0 Adc; I <sub>B1</sub> = 0.1 Adc; -I <sub>B2</sub> = 0.50 Adc | t <sub>off</sub> |  | 1.7 | μs |

**SAFE OPERATING AREA**

|   |        |  |  |  |
|---|--------|--|--|--|
| <b>DC Tests (continuous)</b>  |        |  |  |  |
| T <sub>C</sub> = +25°C; t ≥ 1.0 s (See Figure 3 of MIL-PRF-19500/371)   |        |  |  |  |
| <b>Test 1</b>   |        |  |  |  |
| V <sub>CE</sub> = 28.6 Vdc, I <sub>C</sub> = 3.5 Adc  |        |  |  |  |
| <b>Test 2</b>   |        |  |  |  |
| V <sub>CE</sub> = 70 Vdc, I <sub>C</sub> = 1.43 Adc   |        |  |  |  |
| <b>Test 3</b>   |        |  |  |  |
| V <sub>CE</sub> = 325 Vdc, I <sub>C</sub> = 55 mAdc   | 2N3902 |  |  |  |
| V <sub>CE</sub> = 400 Vdc, I <sub>C</sub> = 35 mAdc   | 2N5157 |  |  |  |
| <b>Switching Tests</b>  |        |  |  |  |
| <b>Load condition C (unclamped inductive load)</b>  |        |  |  |  |
| T <sub>C</sub> = 25°C; duty cycle ≤ 10%; R <sub>S</sub> = 0.1 Ω (See Figure 4 of MIL-PRF-19500/371)   |        |  |  |  |
| <b>Test 1</b>   |        |  |  |  |
| t <sub>p</sub> = approximately 3 ms (vary to obtain I <sub>C</sub> ); R <sub>BB1</sub> = 20 Ω; V <sub>BB1</sub> = 10 Vdc; R <sub>BB2</sub> = 3 kΩ;<br>V <sub>BB2</sub> = 1.5 Vdc; V <sub>CC</sub> = 50 Vdc; I <sub>C</sub> = 3.5 Adc; L = 60 mH; R = 3 Ω; R <sub>L</sub> ≤ 14Ω.   |        |  |  |  |
| <b>Test 2</b>   |        |  |  |  |
| t <sub>p</sub> = approximately 3 ms (vary to obtain I <sub>C</sub> ); R <sub>BB1</sub> = 100 Ω; V <sub>BB1</sub> = 10 Vdc; R <sub>BB2</sub> = 3 kΩ;<br>V <sub>BB2</sub> = 1.5 Vdc; I <sub>C</sub> = 0.6 Adc V <sub>CC</sub> = 50 Vdc; L = 200 mH; R = 8 Ω; R <sub>L</sub> ≤ 83Ω.  |        |  |  |  |
| <b>Switching Tests</b>  |        |  |  |  |
| <b>Load condition (clamped inductive load)</b>  |        |  |  |  |
| T <sub>C</sub> = +25°C; duty cycle ≤ 10%. (See Figure 5 of MIL-PRF-19500/371)   |        |  |  |  |
| <b>Test 1</b>   |        |  |  |  |
| t <sub>p</sub> = approximately 30 ms (vary to obtain I <sub>C</sub> ); R <sub>S</sub> = 0.1 Ω; R <sub>BB1</sub> = 20 Ω; V <sub>BB1</sub> = 10 Vdc; R <sub>BB2</sub> = 100 Ω;<br>V <sub>BB2</sub> = 1.5 Vdc; V <sub>CC</sub> = 50 Vdc; I <sub>C</sub> = 3.5 Adc; L = 60 mH; R = 3 Ω; R <sub>L</sub> ≥ 0Ω.<br>(A suitable clamping circuit or diode can be used.) |        |  |  |  |
| Clamp Voltage = 400 +0, -5 Vdc  | 2N3902 |  |  |  |
| Clamp Voltage = 500 +0, -5 Vdc  | 2N5157 |  |  |  |
| (Clamped voltage must be reached)   |        |  |  |  |

3.) Pulse Test: Pulse Width = 300μs, Duty Cycle ≤ 2.0%.



LittleDiode supplies new, hard to find or obsolete electronic components and semiconductors all over the world.

With over two million different components listed you are sure to find the part you need.

Feel free to visit us today at our online store:

[LittleDiode.com](http://LittleDiode.com)

Looking forward to providing you with the best possible service.