

IPS521/IPS521S

FULLY PROTECTED HIGH SIDE POWER MOSFET SWITCH

Features

- Over temperature protection (with auto-restart)
- Short-circuit protection (current limit)
- Active clamp
- E.S.D protection
- Status feedback
- Open load detection
- Logic ground isolated from power ground

Product Summary

$R_{ds(on)}$	80m Ω (max)
V_{clamp}	50V
I Limit	10A
$V_{open\ load}$	3V

Description

The IPS521/IPS521S are fully protected five terminal high side switches with built in short-circuit , over-temperature, ESD protection, inductive load capability and diagnostic feedback. The output current is controlled when it reaches I_{lim} value. The current limitation is activated until the thermal protection acts. The over-temperature protection turns off the high side switch if the junction temperature exceeds $T_{shutdown}$. It will automatically restart after the junction has cooled 7°C below $T_{shutdown}$. A diagnostic pin is provided for status feedback of short-circuit, over-temperature and open load detection. The double level shifter circuitry allows large offsets between the logic ground and the load ground.

Truth Table

Op. Conditions	In	Out	Dg
Normal	H	H	H
Normal	L	L	L
Open load	H	H	H
Open load	L	H	H
Over current	H	L (limiting)	L
Over current	L	L	L
Over-temperature	H	L (cycling)	L
Over-temperature	L	L	L

Typical Connection

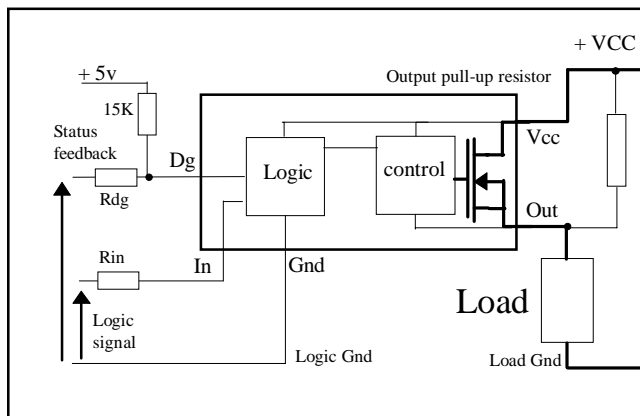

Packages

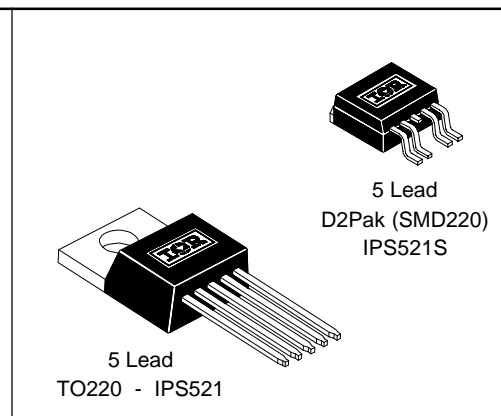

IPS521/IPS521S

Absolute Maximum Ratings

Absolute maximum ratings indicate sustained limits beyond which damage to the device may occur. All voltage parameters are referenced to GROUND lead. ($T_j = 25^\circ\text{C}$ unless otherwise specified).

Symbol	Parameter	Min.	Max.	Units	Test Conditions
V_{out}	Maximum output voltage	$V_{CC}-50$	$V_{CC}+0.3$	V	
V_{offset}	Maximum logic ground to load ground offset	$V_{CC}-50$	$V_{CC}+0.3$		
V_{in}	Maximum Input voltage	-0.3	7		
$I_{in, max}$	Maximum positive IN current	-5	10	mA	
V_{dg}	Maximum diagnostic output voltage	-0.3	7	V	
$I_{dg, max}$	Maximum diagnostic output current	-1	10	mA	
$I_{sd cont.}$	Diode max. permanent current ⁽¹⁾ ($r_{th}=62^\circ\text{C}/\text{W}$)	—	2.2	A	
$I_{sd pulsed}$	Diode max. pulsed current ⁽¹⁾	—	10		
ESD1	Electrostatic discharge voltage (Human Body)	—	4	kV	C=100pF, R=1500Ω,
ESD2	Electrostatic discharge voltage (Machine Model)	—	0.5		C=200pF, R=0Ω, L=10μH
P_d	Maximum power dissipation ⁽¹⁾ ($TC=25^\circ\text{C}$) IPS521	—	40	W	
	($TC=25^\circ\text{C}$) IPS521S	—	1.56		
$T_j \text{ max.}$	Max. storage & operating junction temp.	-40	+150	°C	
T_{lead}	Lead temperature (soldering 10 seconds)	—	300		
$V_{cc \text{ max.}}$	Maximum Vcc voltage	—	50		V

Thermal Characteristics

Symbol	Parameter	Min.	Typ.	Max.	Units	Test Conditions
$R_{th \ 1}$	Thermal resistance junction to case	—	3	—	°C/W	TO-220
$R_{th \ 2}$	Thermal resistance junction ambient	—	60	—		
$R_{th \ 1}$	Thermal resistance with standard footprint	—	60	—		D ² PAK (SMD220)
$R_{th \ 2}$	Thermal resistance with 1" square footprint	—	35	—		
$R_{th \ 3}$	Thermal resistance junction to case	—	3	—		

(1) Limited by junction temperature (pulsed current limited also by internal wiring)

Recommended Operating Conditions

These values are given for a quick design. For operation outside these conditions, please consult the application notes.

Symbol	Parameter	Min.	Max.	Units
V _{CC}	Continuous V _{CC} voltage	5.5	35	V
V _{IH}	High level input voltage	4	5.5	
V _{IL}	Low level input voltage	-0.3	0.9	
I _{out}	Continuous output current (T _{amb} = 85°C, T _j = 125°C, R _{th} = 60°C/W,) IPS521	—	2.2	A
I _{out}	Continuous output current (T _{amb} = 85°C, T _j = 125°C, R _{th} = 80°C/W,) IPS521S	—	1.9	
R _{in}	Recommended resistor in series with IN pin	4	6	kΩ
R _{dg}	Recommended resistor in series with DG pin	10	20	

Static Electrical Characteristics

(T_j = 25°C, V_{CC} = 14V unless otherwise specified.)

Symbol	Parameter	Min.	Typ.	Max.	Units	Test Conditions
R _{ds(on)} @T _j =25°C	ON state resistance T _j = 25°C	—	55	80	mΩ	V _{in} = 5V, I _{out} = 5A
R _{ds(on)} (V _{CC} =6V)	ON state resistance @ V _{CC} = 6V	—	55	80		V _{in} = 5V, I _{out} = 2.5A
R _{ds(on)} @T _j =150°C	ON state resistance T _j = 150°C	—	110	140		V _{in} = 5V, I _{out} = 5A
V _{CC oper.}	Operating voltage range	5.5	—	35	V	
V clamp 1	V _{CC} to OUT clamp voltage 1	50	55	—		I _d = 10mA (see Fig.1 & 2)
V clamp 2	V _{CC} to OUT clamp voltage 2	—	56	65		I _d = I _{sd} (see Fig.1 & 2)
V _f	Body diode forward voltage	—	0.9	1.2		I _d = 2.5A, V _{in} = 0V
I _{CC off}	Supply current when OFF	—	16	50	μA	V _{in} = 0V, V _{out} = 0V
I _{CC on}	Supply current when ON	—	0.6	2	mA	V _{in} = 5V
I _{CC ac}	Ripple current when ON (AC RMS)	—	20	—	μA	V _{in} = 5V
V _{dg1}	Low level diagnostic output voltage	—	0.15	0.4	V	I _{dg} = 1.6 mA
I _{oh}	Output leakage current	—	50	120	μA	V _{out} = 6V
I _{ol}	Output leakage current	0	—	25		V _{out} = 0V
I _{dg leakage}	Diagnostic output leakage current	—	—	10		V _{dg} = 5.5V
V _{ih}	IN high threshold voltage	—	2.2	3	V	
V _{il}	IN low threshold voltage	1	1.9	—		
I _{in, on}	On state IN positive current	—	70	200	μA	V _{in} = 5V
I _{n hyst}	Input hysteresis	0.1	0.25	0.5	V	

Switching Electrical Characteristics

$V_{CC} = 14V$, Resistive Load = 2.8Ω , $T_j = 25^\circ C$, (unless otherwise specified).

Symbol	Parameter	Min.	Typ.	Max.	Units	Test Conditions
T_{don}	Turn-on delay time	—	10	40	μs	See figure 3
T_{r1}	Rise time to $V_{out} = V_{CC} - 5V$	—	25	60		
T_{r2}	Rise time $V_{CC} - 5V$ to $V_{out} = 90\%$ of V_{CC}	—	130	200		
dV/dt (on)	Turn ON dV/dt	—	0.7	2	$V/\mu s$	
E_{on}	Turn ON energy	—	1500	—	μJ	
T_{doff}	Turn-off delay time	—	35	70	μs	See figure 4
T_f	Fall time to $V_{out} = 10\%$ of V_{CC}	—	25	50		
dV/dt (off)	Turn OFF dV/dt	—	0.9	3	$V/\mu s$	
E_{off}	Turn OFF energy	—	250	—	μJ	
T_{diag}	V_{out} to V_{diag} propagation delay	—	5	15	μs	See figure 6

Protection Characteristics

Symbol	Parameter	Min.	Typ.	Max.	Units	Test Conditions
I_{lim}	Internal current limit	7	10	14	A	$V_{out} = 0V$
T_{sd+}	Over-temp. positive going threshold	—	165	—	$^\circ C$	See fig. 2
T_{sd-}	Over-temp. negative going threshold	—	158	—		See fig. 2
V_{sc}	Short-circuit detection voltage (3)	2	3	4	V	See fig. 2
$V_{open load}$	Open load detection threshold	2	3	4		

(3) Referenced to V_{CC}

Lead Assignments

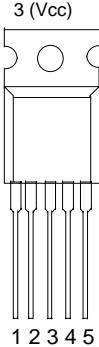
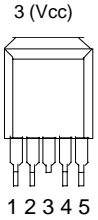
 <p>3 (Vcc)</p> <p>1 2 3 4 5</p>	<p>1 - Ground 2 - In 3 - Vcc 4 - DG 5 - Out</p>	 <p>3 (Vcc)</p> <p>1 2 3 4 5</p>
5 Lead - TO220		5 Lead - D ² PAK (SMD220)
IPS521		IPS521S
Part Number		

Functional Block Diagram

All values are typical

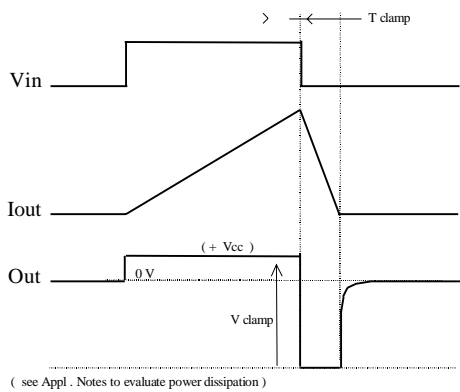
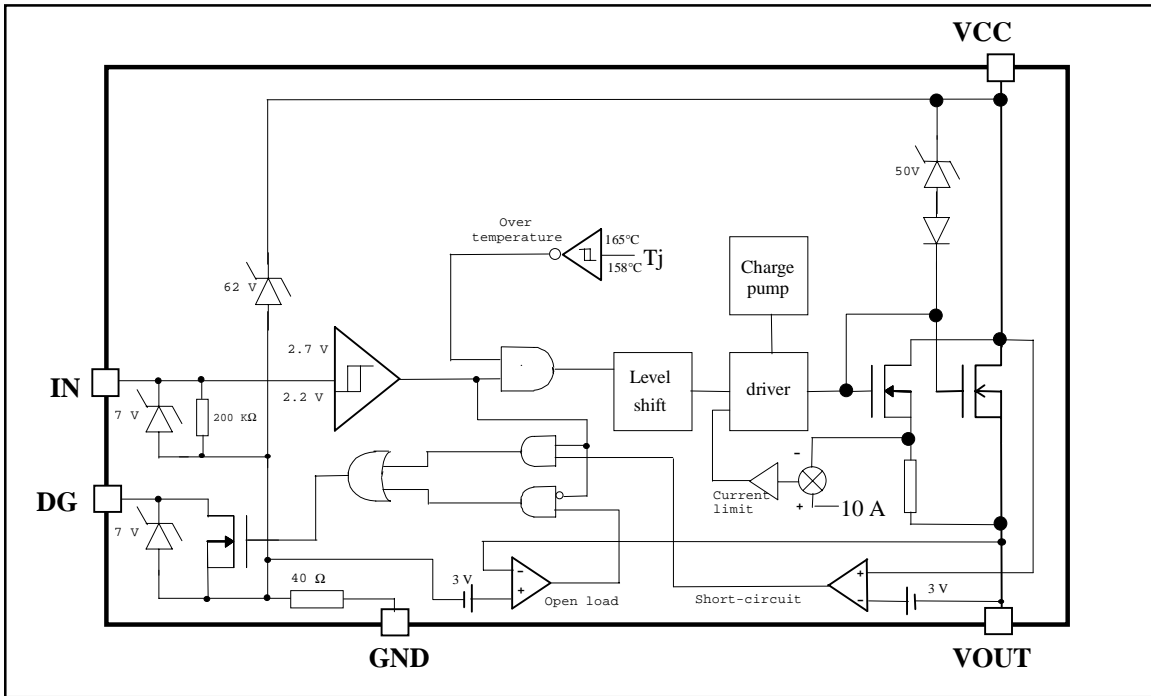

Figure 1 - Active clamp waveforms

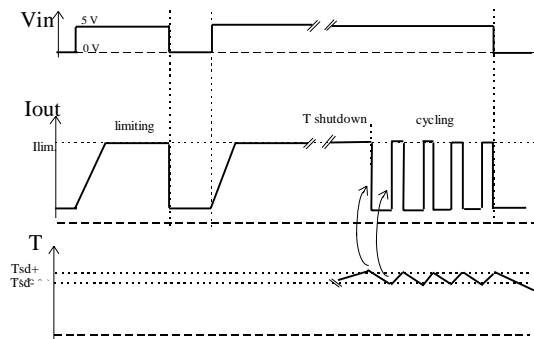

Figure 2 - Protection timing diagram

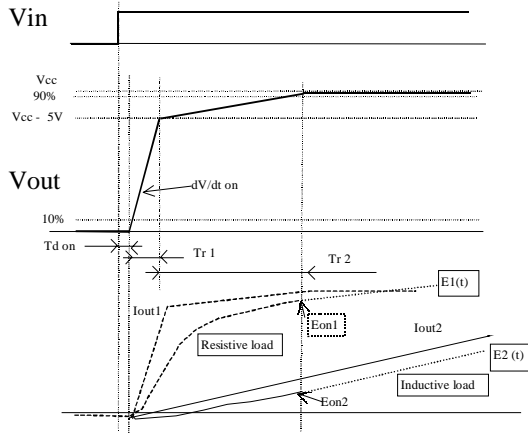

Figure 3 - Switching times definition (turn-on)
Turn on energy with a resistive or an inductive load

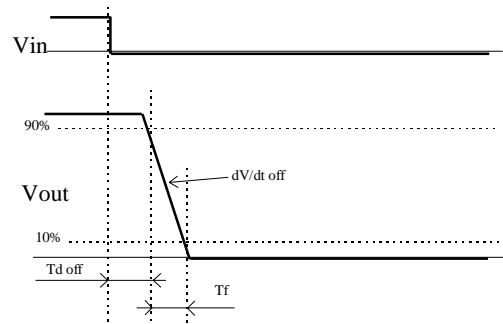

Figure 4 - Switching times definition (turn-off)

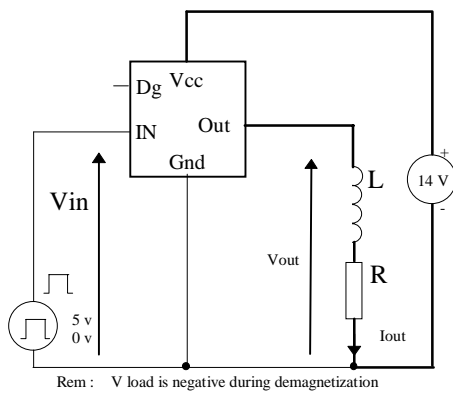

Figure 5 - Active clamp test circuit

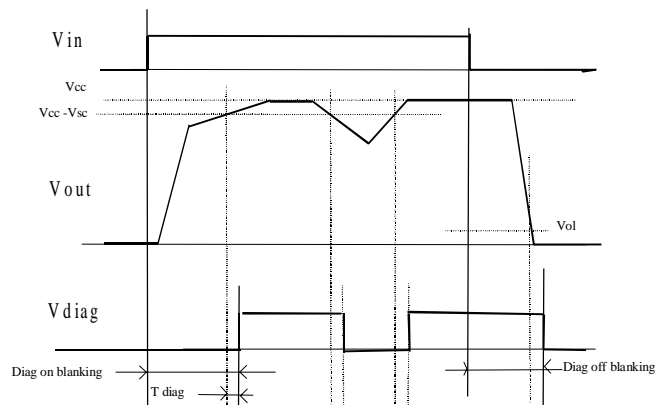

Figure 6 - Diagnostic delay definitions

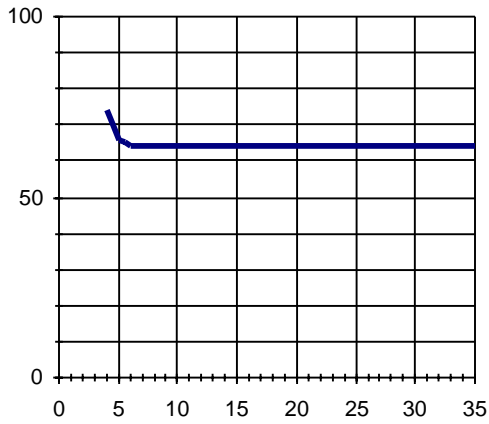

Figure 7 - R_{ds(on)} (mΩ) Vs V_{CC} (V)

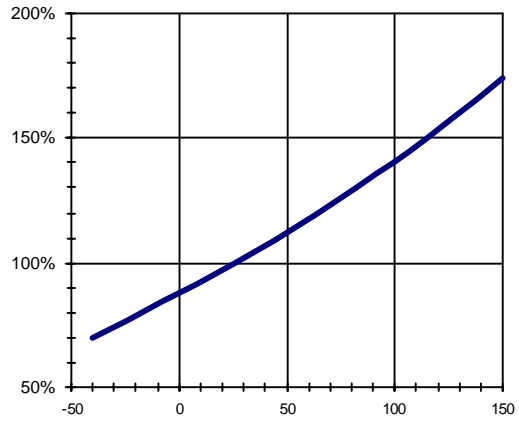

Figure 8 - Normalized R_{ds(on)} (%) Vs T_j (°C)

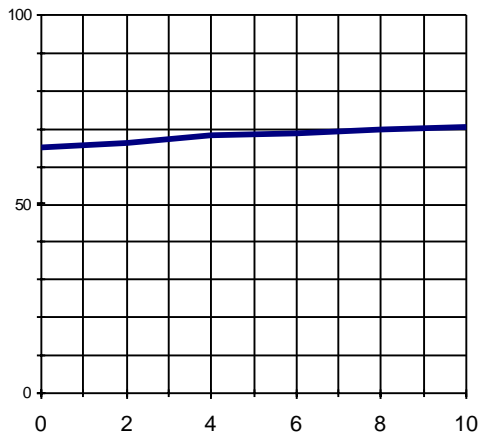

Figure 9 - R_{ds(on)} (mΩ) Vs I_{out} (A)

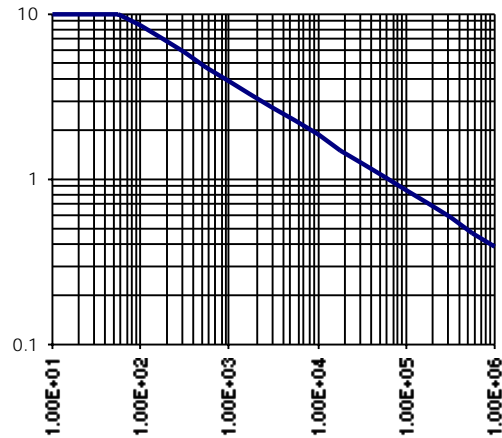

Figure 10 - Max. I_{out} (A) Vs Load Inductance (uH)

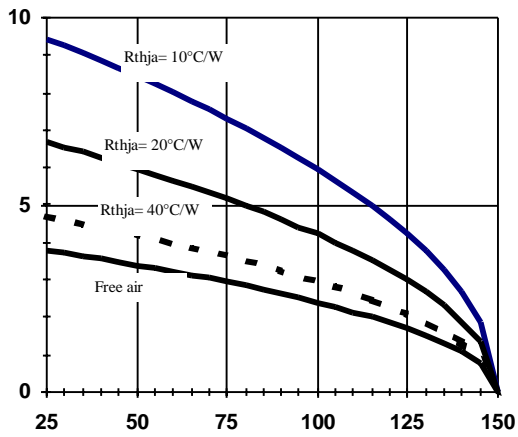

Figure 11a - Max load current (A) Vs Tamb (°C)
IPS521

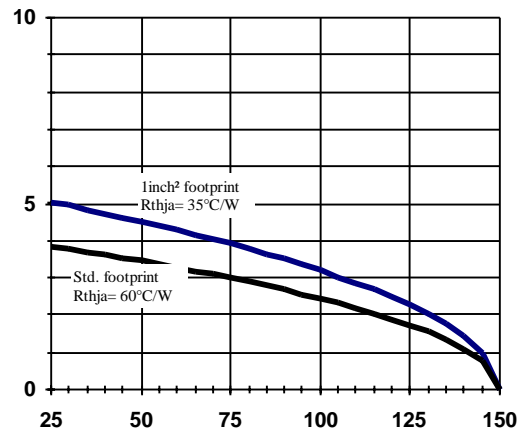

Figure 11b - Max load current (A) Vs Tamb (°C)
IPS521S

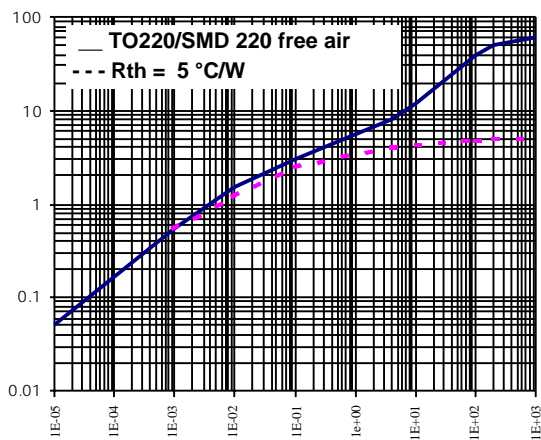

Figure 12 - Transient Thermal Impedance (°C/W)
Vs Time (S)

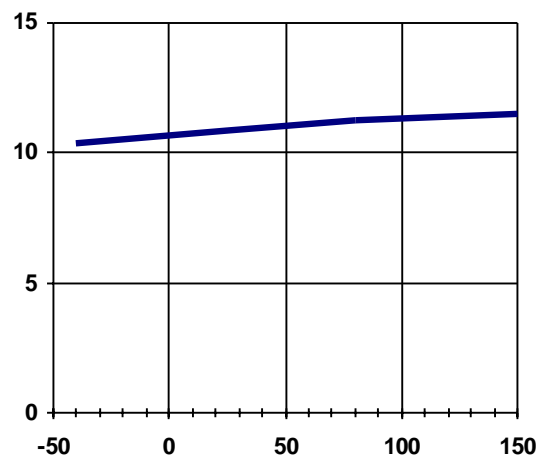

Figure 13 - I_{lim} (A) Vs T_j (°C)

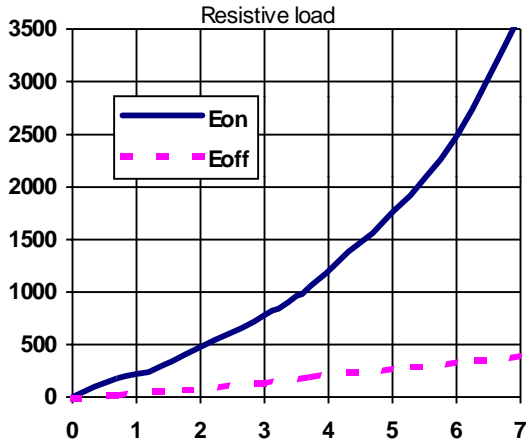

Figure 14 - E_{on} , E_{off} (μ J) Vs I_{out} (A)

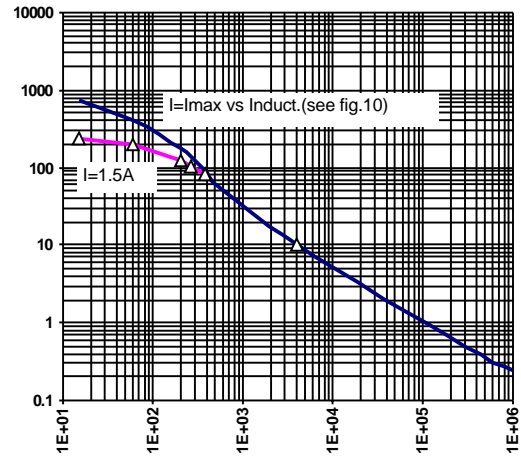

Figure 15 - E_{on} (μ J) Vs Load Inductance (μ H)
(see Fig. 3)

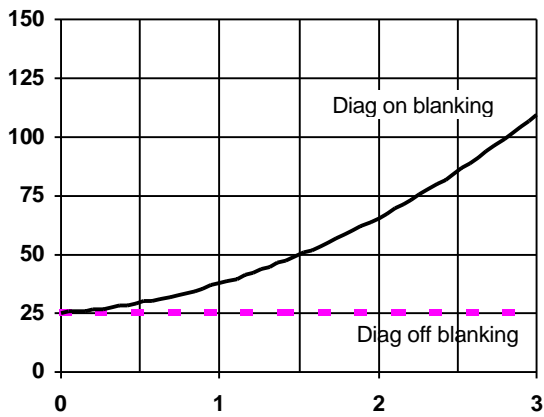

Figure 16 - Diag Blanking time (μ s) Vs I_{out} (A)
(resistive load - see Fig. 6)

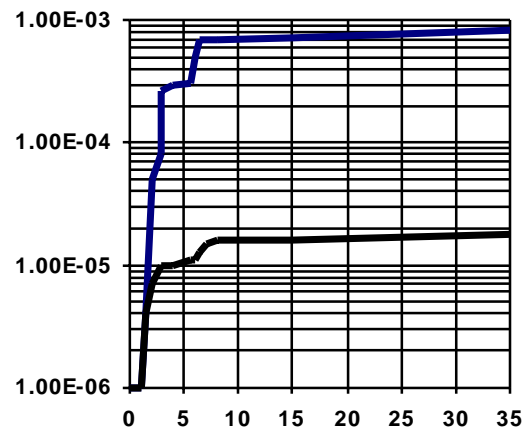
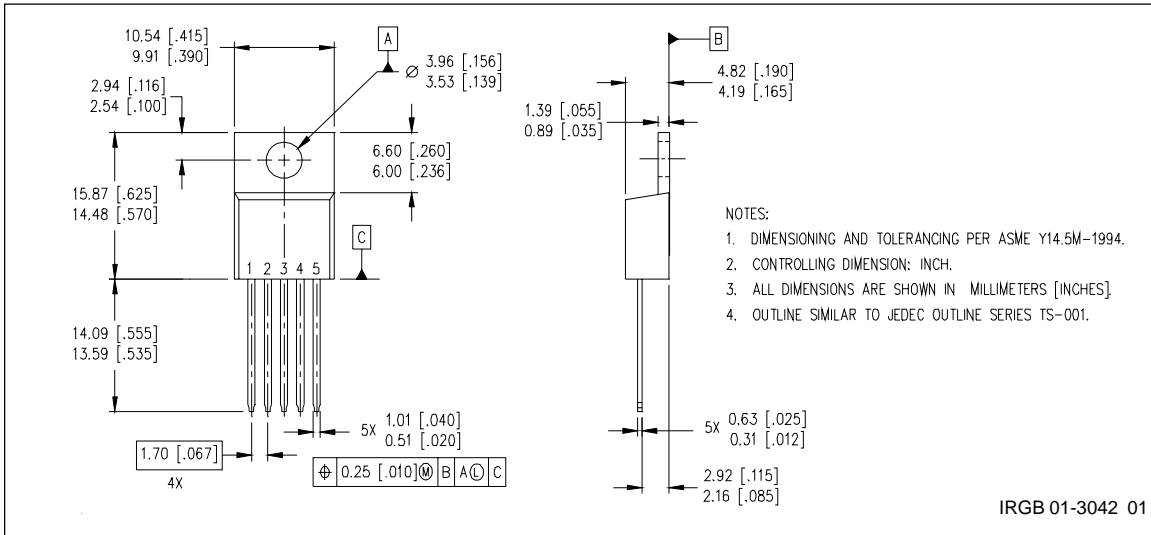

Figure 17 - I_{cc} (mA) Vs V_{cc} (V)

IPS521/IPS521S

International
IR Rectifier

Case Outline 5 Lead - TO220



Tape & Reel 5 Lead - D²PAK (SMD220)

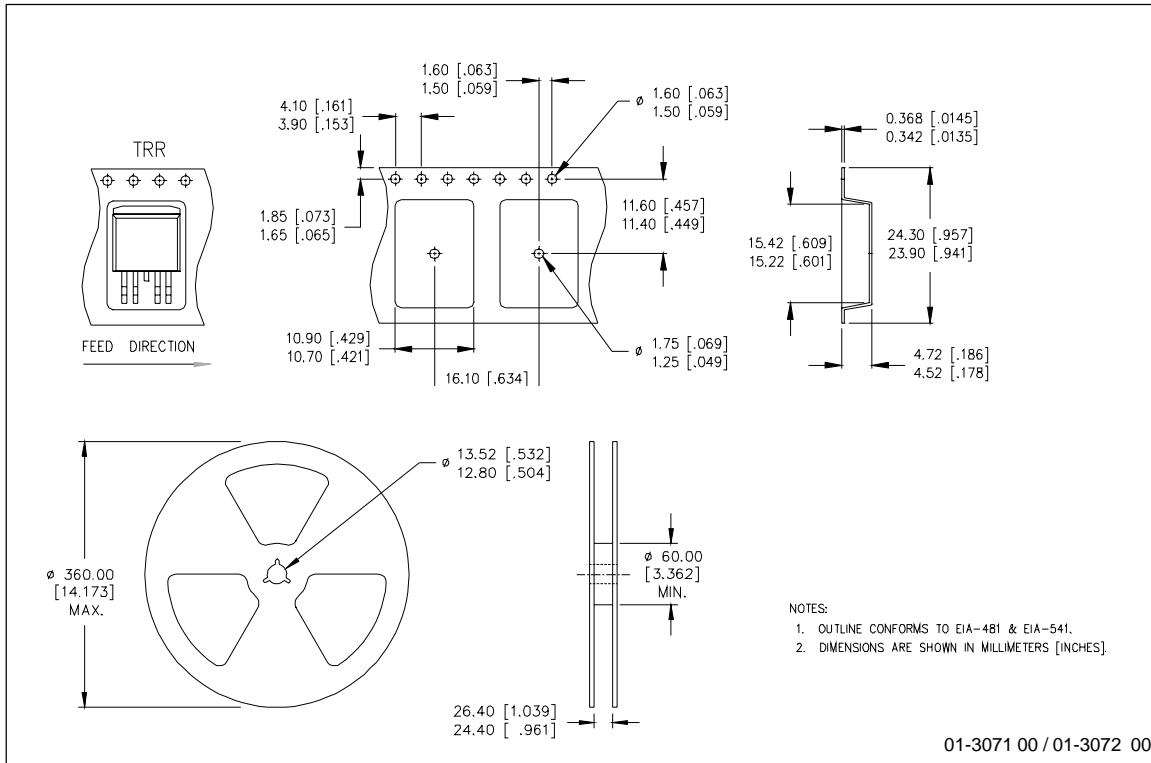

Case Outline 5 Lead - D²PAK (SMD220)

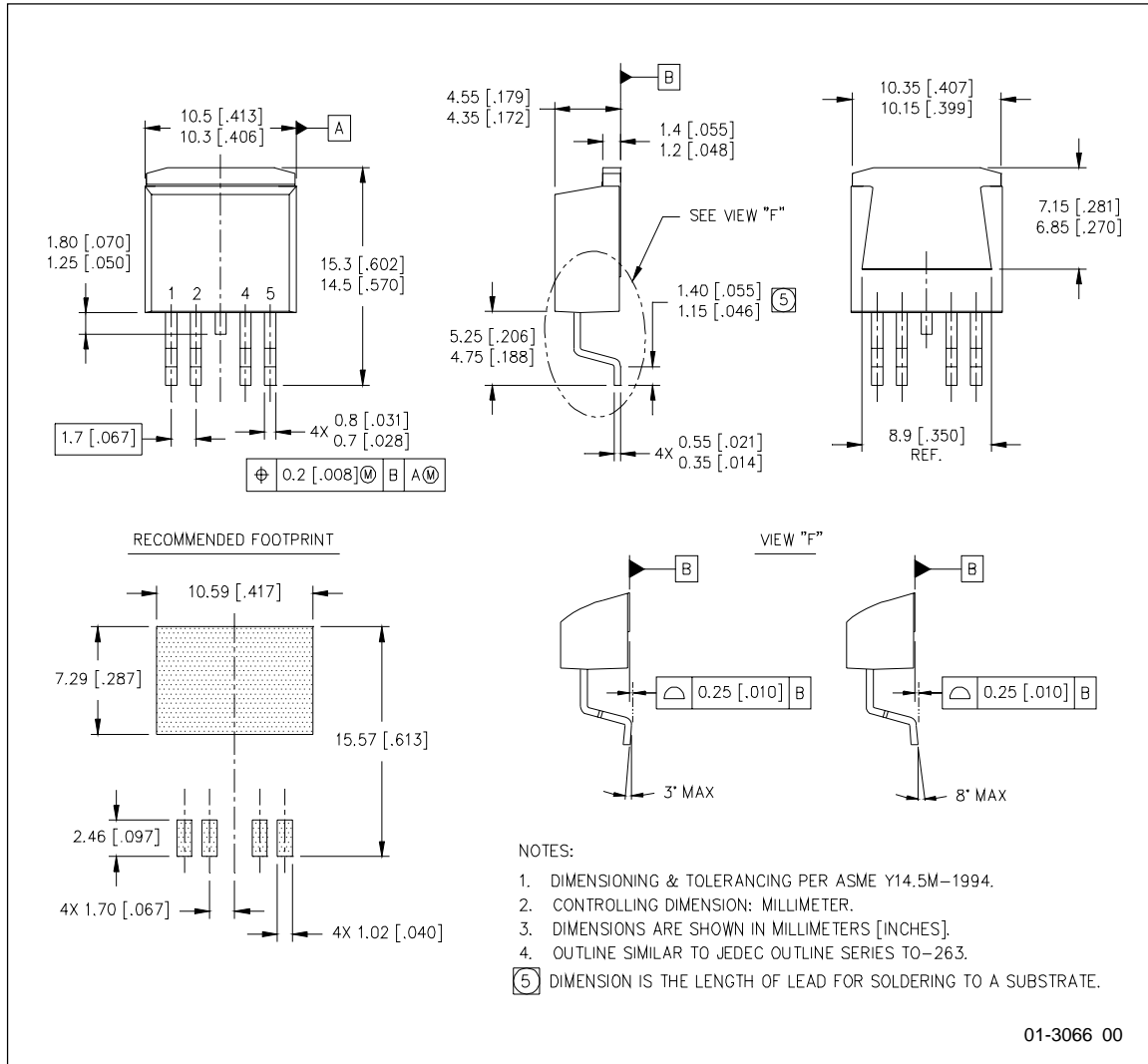



LittleDiode supplies new, hard to find or obsolete electronic components and semiconductors all over the world.

With over two million different components listed you are sure to find the part you need.

Feel free to visit us today at our online store:

LittleDiode.com

Looking forward to providing you with the best possible service.