

**CMPD5001
CMPD5001S**

**HIGH CURRENT
INDUCTIVE LOAD
SWITCHING DIODE**

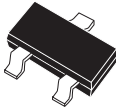

SOT-23 CASE

DESCRIPTION:

The CENTRAL SEMICONDUCTOR CMPD5001 series types are silicon switching diodes manufactured by the epitaxial planar process, designed for switching inductive load applications requiring extremely high current capability.

The following configurations are available:

CMPD5001	SINGLE
CMPD5001S	DUAL, IN SERIES

MARKING CODE: DA2

MARKING CODE: D49

MAXIMUM RATINGS ($T_A=25^{\circ}\text{C}$)

	SYMBOL		UNITS
Continuous Reverse Voltage	V_R	120	V
Continuous Forward Current	I_F	400	mA
Peak Repetitive Forward Current	I_{FRM}	800	mA
Peak Repetitive Reverse Current	I_{RRM}	600	mA
Forward Surge Current, $t_p=1 \mu\text{s}$	I_{FSM}	6000	mA
Forward Surge Current, $t_p=1 \text{ s}$	I_{FSM}	1500	mA
Power Dissipation	P_D	350	mW
Operating and Storage			
Junction Temperature	T_J, T_{stg}	-65 to +150	$^{\circ}\text{C}$
Thermal Resistance	θ_{JA}	357	$^{\circ}\text{C}/\text{W}$

ELECTRICAL CHARACTERISTICS ($T_A=25^{\circ}\text{C}$ unless otherwise noted)

SYMBOL	TEST CONDITIONS	MIN	MAX	UNITS
B_{VR}	$I_R=1.0\text{mA}$	120	175	V
I_R	$V_R=90\text{V}$		100	nA
I_R	$V_R=90\text{V}, T_A=150^{\circ}\text{C}$		100	μA
V_F	$I_F=10\text{mA}$		0.75	V
V_F	$I_F=50\text{mA}$		0.84	V
V_F	$I_F=100\text{mA}$		0.90	V
V_F	$I_F=200\text{mA}$		1.00	V

SYMBOL	TEST CONDITIONS	MIN	MAX	UNITS
V_F	$I_F=400\text{mA}$		1.25	V
C_T	$V_R=0, f=1\text{ MHz}$		35	pF
t_{rr}	$I_F=I_R=30\text{mA}, \text{RECOV. TO } 1.0\text{mA}, R_L=100\Omega$		60	ns
t_{rr}	$I_F=I_R=10\text{mA}, \text{RECOV. TO } 1.0\text{mA}, R_L=100\Omega$		50	ns

All dimensions in inches (mm).

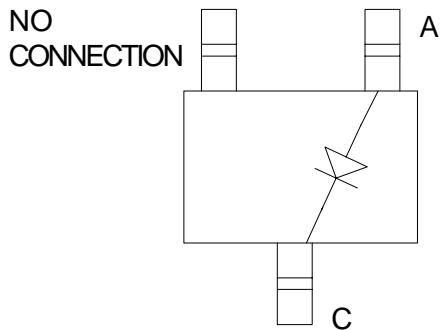
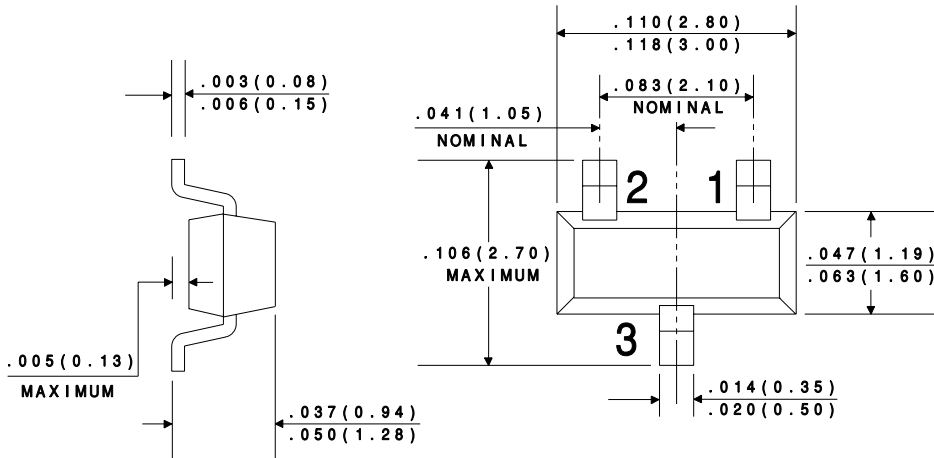

CMPD5001

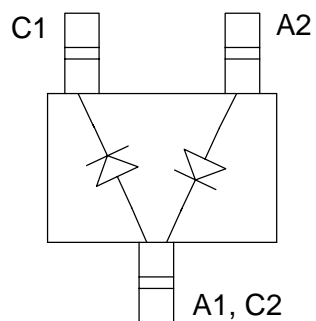

CMPD5001S



LittleDiode supplies new, hard to find or obsolete electronic components and semiconductors all over the world.

With over two million different components listed you are sure to find the part you need.

Feel free to visit us today at our online store:

LittleDiode.com

Looking forward to providing you with the best possible service.