

2SJ175

SILICON P-CHANNEL MOS FET

HIGH SPEED POWER SWITCHING

■ FEATURES

- Low On-Resistance
- High Speed Switching
- Low Drive Current
- 4 V Gate Drive Device
 - Can be driven from 5 V source
- Suitable for Motor Drive, DC-DC Converter, Power Switch and Solenoid Drive

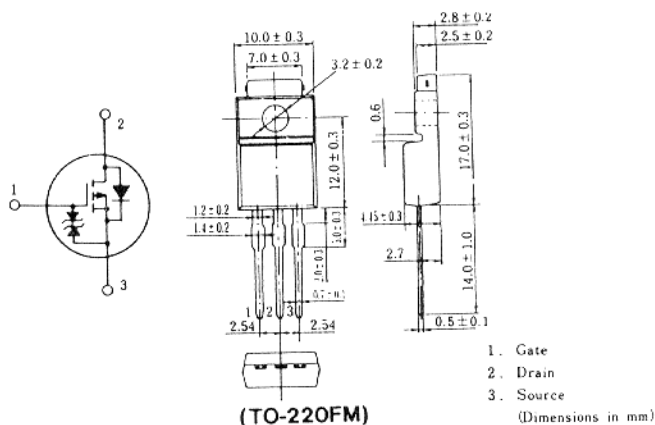

(TO-220FM)

1. Gate
2. Drain
3. Source
(Dimensions in mm)

■ ABSOLUTE MAXIMUM RATINGS ($T_a=25^\circ\text{C}$)

Item	Symbol	Rating	Unit
Drain-Source Voltage	V_{DS}	-60	V
Gate-Source Voltage	V_{GS}	± 20	V
Drain Current	I_D	-10	A
Drain Peak Current	$I_{D(\text{pulse})}$ *	-40	A
Body-Drain Diode Reverse Drain Current	I_{DR}	-10	A
Channel Dissipation	P_{ch} **	25	W
Channel Temperature	T_{ch}	150	$^\circ\text{C}$
Storage Temperature	T_{stg}	-55 ~ +150	$^\circ\text{C}$

* $PW \leq 10 \mu\text{s}$, duty cycle $\leq 1\%$
** Value at $T_c=25^\circ\text{C}$

POWER VS. TEMPERATURE DERATING

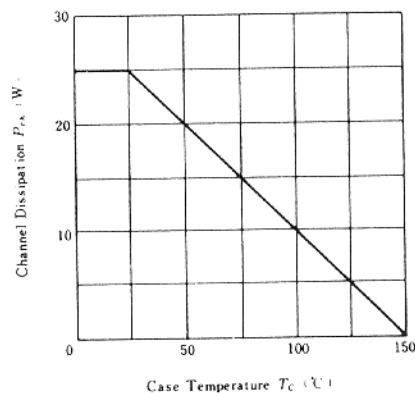

■ ELECTRICAL CHARACTERISTICS ($T_a=25^\circ\text{C}$)

Item	Symbol	Test Condition	min.	typ.	max.	Unit
Drain-Source Breakdown Voltage	$V_{(BR)DS}$	$I_D = -10\text{mA}$, $V_{GS} = 0$	-60	—	—	V
Gate-Source Breakdown Voltage	$V_{(BR)GS}$	$I_G = \pm 100 \mu\text{A}$, $V_{DS} = 0$	± 20	—	—	V
Gate-Source Leak Current	I_{GSS}	$V_{GS} = \pm 16\text{V}$, $V_{DS} = 0$	—	—	± 10	μA
Zero Gate Voltage Drain Current	I_{DSS}	$V_{DS} = -50\text{V}$, $V_{GS} = 0$	—	—	-250	μA
Gate-Source Cutoff Voltage	$V_{GS(\text{off})}$	$I_D = -1\text{mA}$, $V_{DS} = -10\text{V}$	-1.0	—	-2.0	V
Static Drain-Source on State Resistance	$R_{DS(\text{on})}$	$I_D = -5\text{A}$, $V_{GS} = -10\text{V}$ *	—	0.13	0.18	Ω
		$I_D = -5\text{A}$, $V_{GS} = -4\text{V}$ *	—	0.18	0.25	
Forward Transfer Admittance	$ y_{fs} $	$I_D = -5\text{A}$, $V_{DS} = -10\text{V}$ *	4.0	6.5	—	S
Input Capacitance	C_{iss}	$V_{DS} = -10\text{V}$, $V_{GS} = 0$ $f = 1\text{MHz}$	—	900	—	μF
Output Capacitance	C_{oss}		—	460	—	μF
Reverse Transfer Capacitance	C_{rss}		—	130	—	μF
Turn-on Delay Time	$t_{d(\text{on})}$	$I_D = -5\text{A}$, $V_{GS} = -10\text{V}$ $R_L = 6\Omega$	—	8	—	ns
Rise Time	t_r		—	65	—	ns
Turn-off Delay Time	$t_{d(\text{off})}$		—	170	—	ns
Fall Time	t_f		—	105	—	ns
Body-Drain Diode Forward Voltage	V_{DF}	$I_F = -10\text{A}$, $V_{GS} = 0$	—	-1.1	—	V
Body-Drain Diode Reverse Recovery Time	t_{rr}	$I_F = -10\text{A}$, $V_{GS} = 0$ $di_F/dt = 50\text{A}/\mu\text{s}$	—	200	—	ns

* Pulse Test

■ See characteristic curves of 2SJ172

MAXIMUM SAFE OPERATION AREA

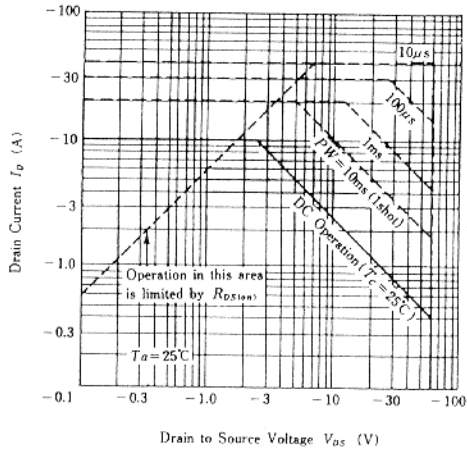

NORMALIZED TRANSIENT THERMAL IMPEDANCE VS. PULSE WIDTH

