

SGS-THOMSON

3DE D  
HIGH VOLTAGE POWER SWITCH

**DESCRIPTION**

The BUX47/A, BUV47/A, BUV47FI/AFI are silicon multiepitaxial mesa NPN transistors mounted respectively in TO-3 metal case, TO-218 plastic package and ISOWATT218 fully isolated package. They are intended for high voltage, fast switching applications.

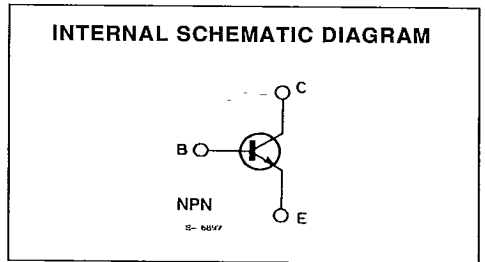
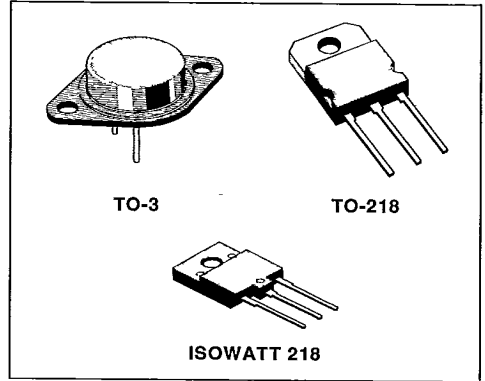

**ABSOLUTE MAXIMUM RATINGS**

Symbol	Parameter	Value			Unit
		BUX47 BUV47 BUX47FI	BUX47A BUV47A BUX47AFI		
V <sub>CER</sub>	Collector-emitter Voltage (R <sub>BE</sub> = 10 Ω)	850	1000		V
V <sub>CES</sub>	Collector-emitter Voltage (V <sub>BE</sub> = 0)	850	900		V
V <sub>CEO</sub>	Collector-emitter Voltage (I <sub>B</sub> = 0)	400	450		V
V <sub>EBO</sub>	Emitter-base Voltage (I <sub>C</sub> = 0)		7		V
I <sub>C</sub>	Collector Current		9		A
I <sub>CM</sub>	Collector Peak Current (t <sub>p</sub> < 5 ms)		15		A
I <sub>B</sub>	Base Current		8		A
I <sub>BM</sub>	Base Peak Current (t <sub>p</sub> < 5 ms)		10		A
		<b>TO-3</b>	<b>TO-218</b>	<b>ISOWATT218</b>	
P <sub>tot</sub>	Total Dissipation at T <sub>c</sub> < 25 °C	125	100	55	W
T <sub>stg</sub>	Storage Temperature	- 65 to 175	- 65 to 150	- 65 to 150	°C
T <sub>j</sub>	Max. Operating Junction Temperature	175	150	150	°C

November 1988

1/9

735

7929237 0028982 2

**THERMAL DATA**

			<b>TO-3</b>	<b>TO-218</b>	<b>ISOWATT218</b>	
$R_{th\ j-case}$	Thermal Resistance Junction-case	max	1.2	1.25	2.27	°C/W

**ELECTRICAL CHARACTERISTICS** ( $T_{case} = 25\text{ °C}$  unless otherwise specified)

Symbol	Parameter	Test Conditions	Min.	Typ.	Max.	Unit
$I_{CER}$	Collector Cutoff Current ( $R_{BE} = 10\ \Omega$ )	$V_{CE} = 850\text{ V}$ $V_{CE} = 850\text{ V}$ $T_{case} = 125\text{ °C}$			0.4 3	mA mA
$I_{CEV}$	Collector Cutoff Current ( $V_{BE} = -2.5\text{ V}$ )	$V_{CE} = 850\text{ V}$ $V_{CE} = 850\text{ V}$ $T_{case} = 125\text{ °C}$			0.15 1.5	mA mA
$I_{EBO}$	Emitter Cutoff Current ( $I_C = 0$ )	$V_{EB} = 5\text{ V}$			1	mA
$V_{CEO(sus)}^*$	Collector-emitter Sustaining Voltage ( $I_B = 0$ )	$I_C = 0.2\text{ A}$ $L = 25\text{ mH}$ for BUX47/BUV47/BUV47FI for BUX47A/BUV47A/BUV47AFI	400 450			V V
$V_{EBO}$	Emitter-base Voltage ( $I_C = 0$ )	$I_E = 50\text{ mA}$	7		30	V
$V_{CE(sat)}^*$	Collector-emitter Saturation Voltage	for BUX47A/BUV47A/BUV47AFI $I_C = 5\text{ A}$ $I_B = 1\text{ A}$ $I_C = 8\text{ A}$ $I_B = 2.5\text{ A}$ for BUX47/BUV47/BUV47FI $I_C = 6\text{ A}$ $I_B = 1.2\text{ A}$ $I_C = 9\text{ A}$ $I_B = 3\text{ A}$			1.5 3 1.5 3	V V V V
$V_{BE(sat)}^*$	Base-emitter Saturation Voltage	for BUX47A/BUV47A/BUV47AFI $I_C = 5\text{ A}$ $I_B = 1\text{ A}$ for BUX47/BUV47/BUV47FI $I_C = 6\text{ A}$ $I_B = 1.2\text{ A}$			1.6 1.6	V V

**RESISTIVE SWITCHING TIMES** (see fig. 1)

Symbol	Parameter	Test Conditions	Min.	Typ.	Max.	Unit
$t_{on}$	Turn-on Time	for BUX47A/BUV47A/BUV47AFI			0.7	$\mu\text{s}$
$t_s$	Storage Time	$I_C = 5\text{ A}$ $V_{CC} = 150\text{ V}$			3	$\mu\text{s}$
$t_f$	Fall Time	$I_{B1} = -I_{B2} = 1\text{ A}$			0.8	$\mu\text{s}$
$t_{on}$	Turn-on Time	for BUX47/BUV47/BUV47FI			0.8	$\mu\text{s}$
$t_s$	Storage Time	$I_C = 6\text{ A}$ $V_{CC} = 150\text{ V}$			2.5	$\mu\text{s}$
$t_f$	Fall Time	$I_{B1} = -I_{B2} = 1.2\text{ A}$			0.8	$\mu\text{s}$

**INDUCTIVE SWITCHING TIMES** (see fig. 2)

Symbol	Parameter	Test Conditions	Min.	Typ.	Max.	Unit
$t_f$	Fall Time	$I_C = 5\text{ A}$ $I_{B1} = 1\text{ A}$ $V_{BE} = 5\text{ V}$ $V_{CC} = 300\text{ V}$ $L = 3\ \mu\text{H}$ $T_j = 100\text{ °C}$			0.5	$\mu\text{s}$

\* Pulsed : pulse duration  $\leq 300\ \mu\text{s}$ , duty cycle  $\leq 1.5\%$ .

SGS-THOMSON

30E D

SGS-THOMSON

3OE D

Safe Operating Areas (TO-3).

Safe Operating Areas (TO-218, ISOWATT218).

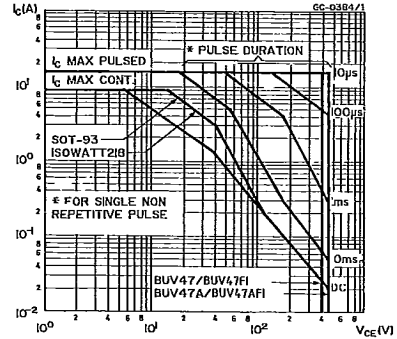
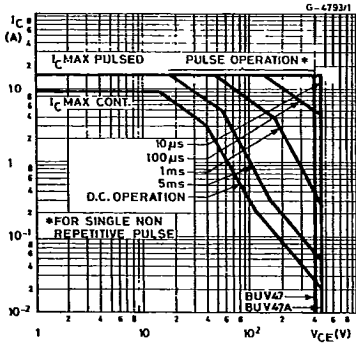

Clamped Reverse Bias Safe Operating Areas.

Forward Biased Accidental Overload Area (see fig. 3).

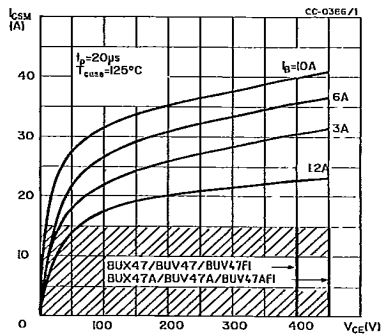
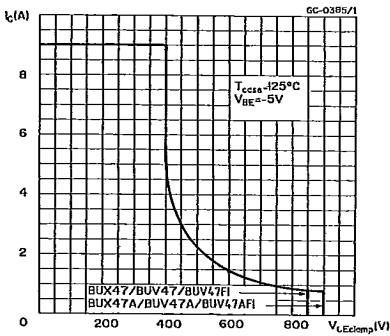

DC Current Gain.

Saturation Voltage.

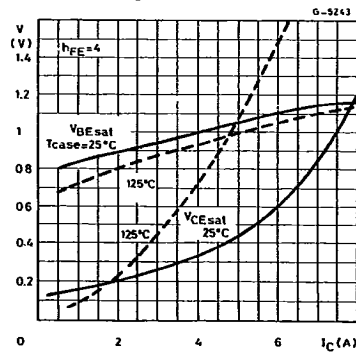
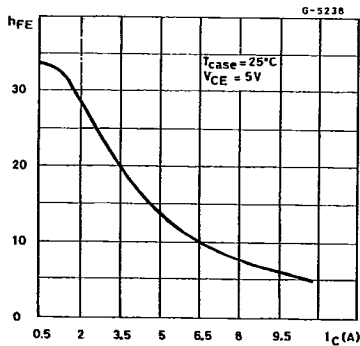

7929237 0028984 6

Collector-emitter Saturation Voltage.

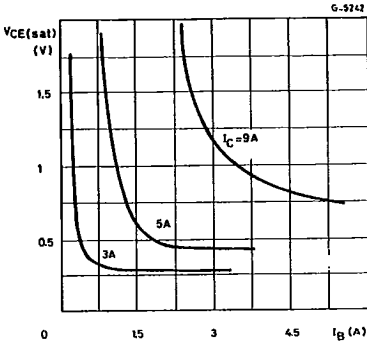

Switching Times Percentage Variation vs. Case Temperature.

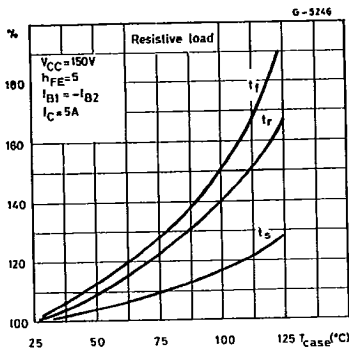

Switching Times Inductive Load (see fig. 2).

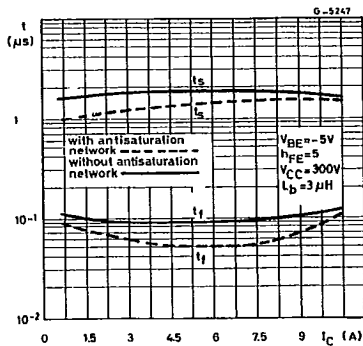

Collector Current Spread vs. Base Emitter Voltage.

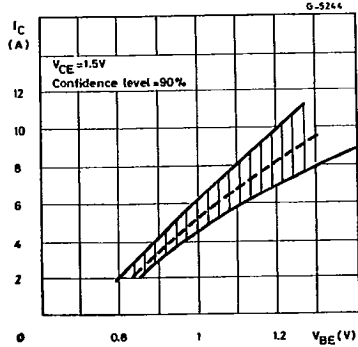

Switching Times Resistive Load (see fig. 1).

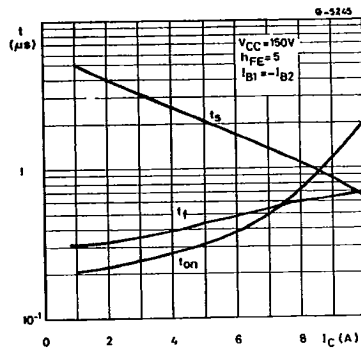

Switching Times Inductive Load vs. Case Temperature.

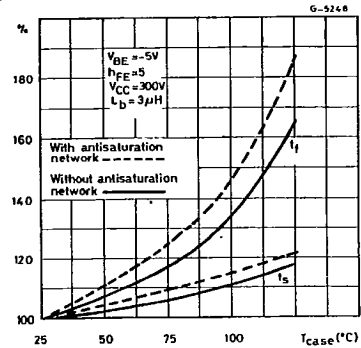

S G S-THOMSON

30E D

Fall Times vs.  $L_b$  (see fig. 2).

Dynamic Collector-emitter Saturation Voltage (see fig. 4).

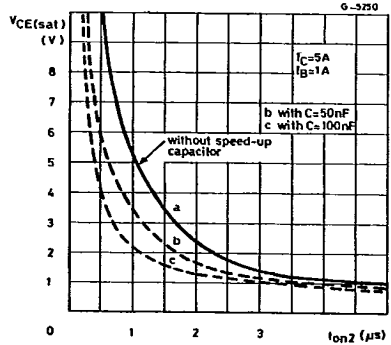
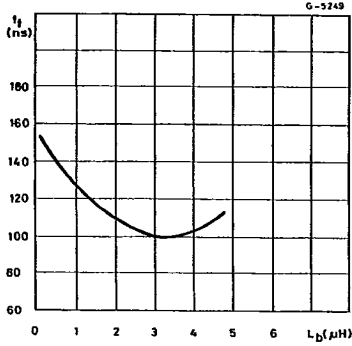
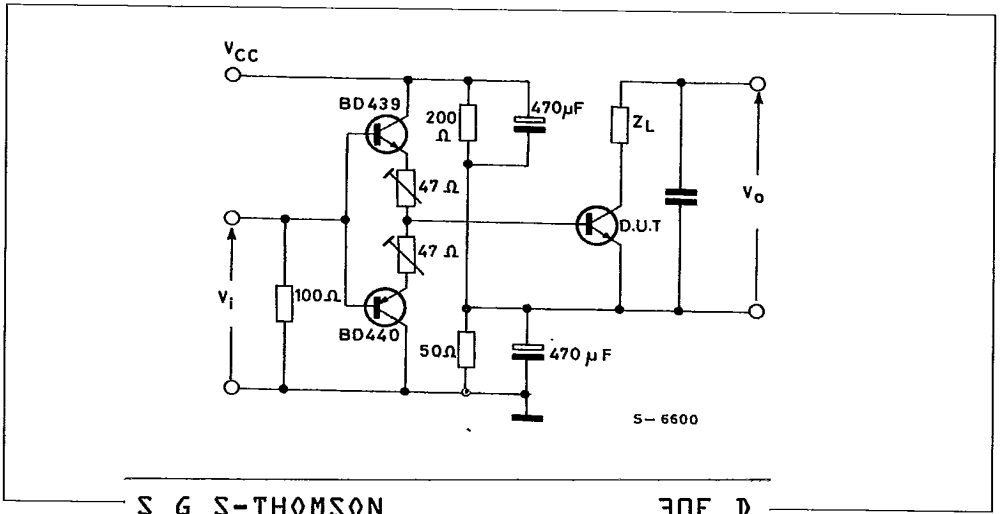

Figure 1 : Switching Times Test Circuit on Resistive Load.



S G S-THOMSON

30E D

7929237 0028986 T

Figure 2 : Switching Times Test Circuit on Inductive Load. With and without Antisaturation Network.

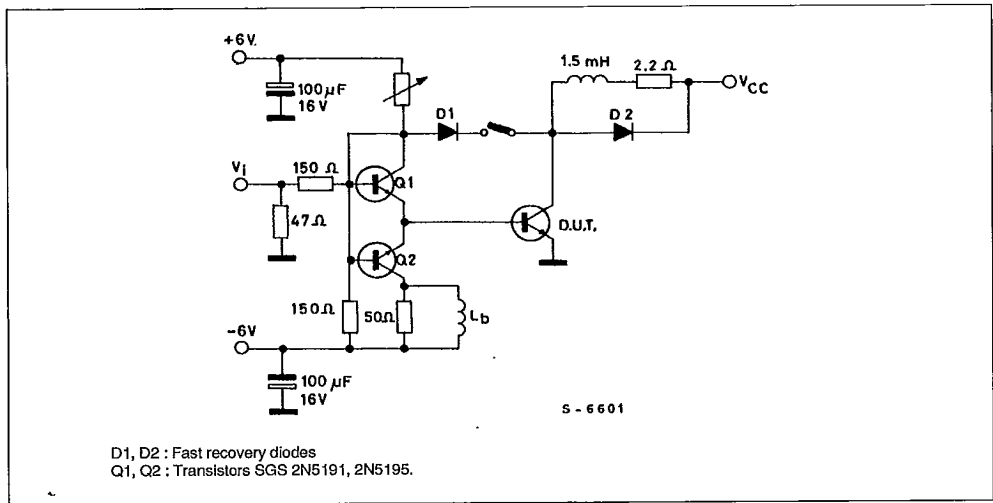
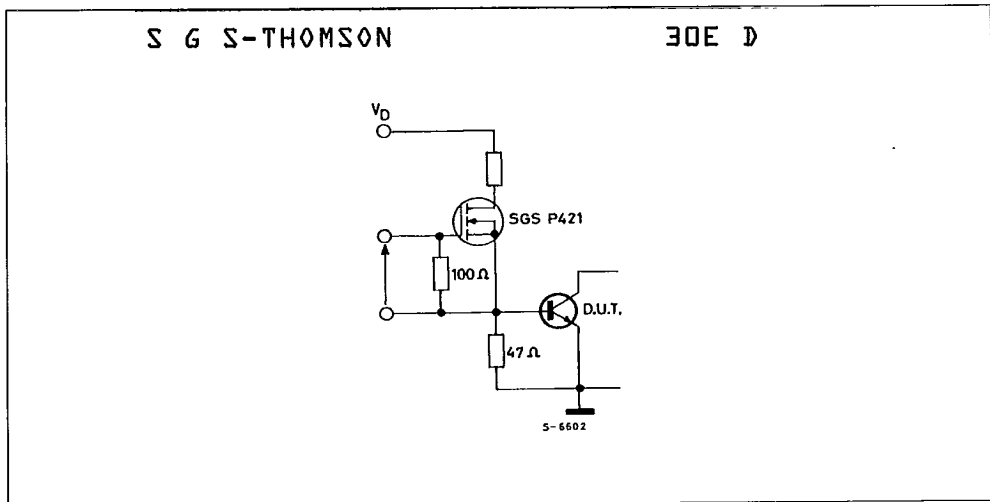

Figure 3 : Forward Biased Accidental Overload Area Test Circuit.



7929237 0028987 1

Figure 4 : V<sub>CE(sat)</sub> Dyn. Test Circuit.

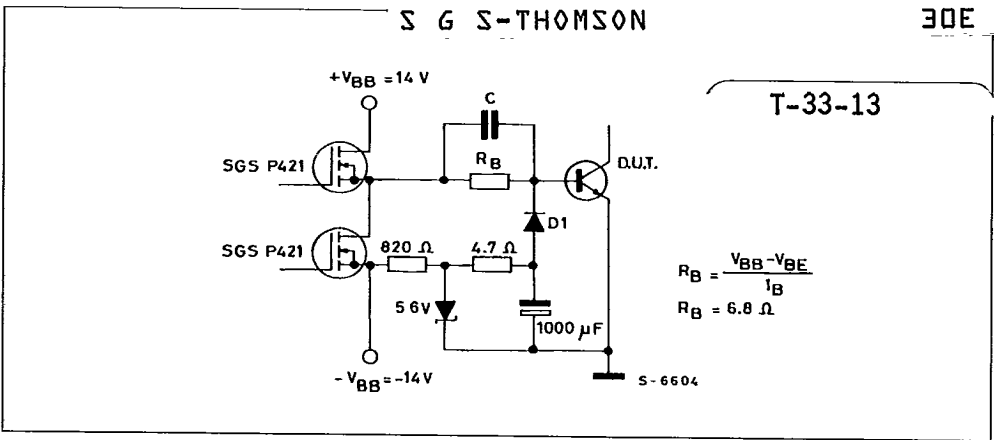

Figure 5 : Equivalent Input Schematic Circuit at Turn-on.

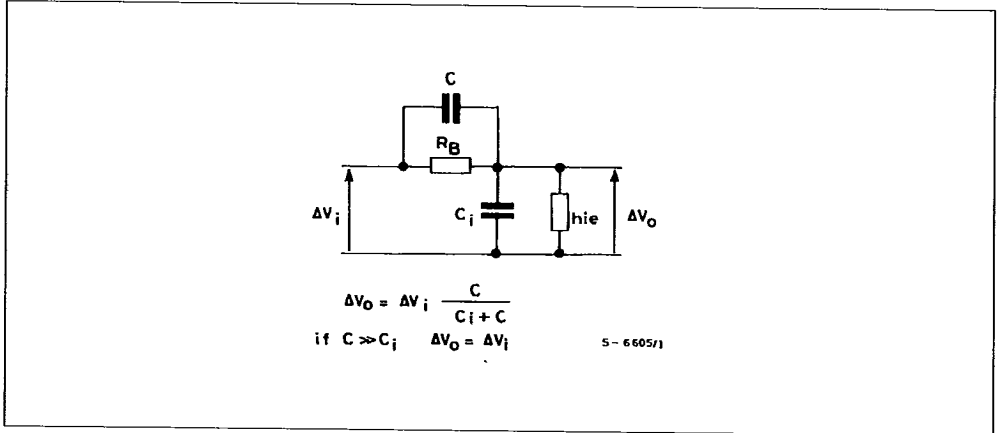
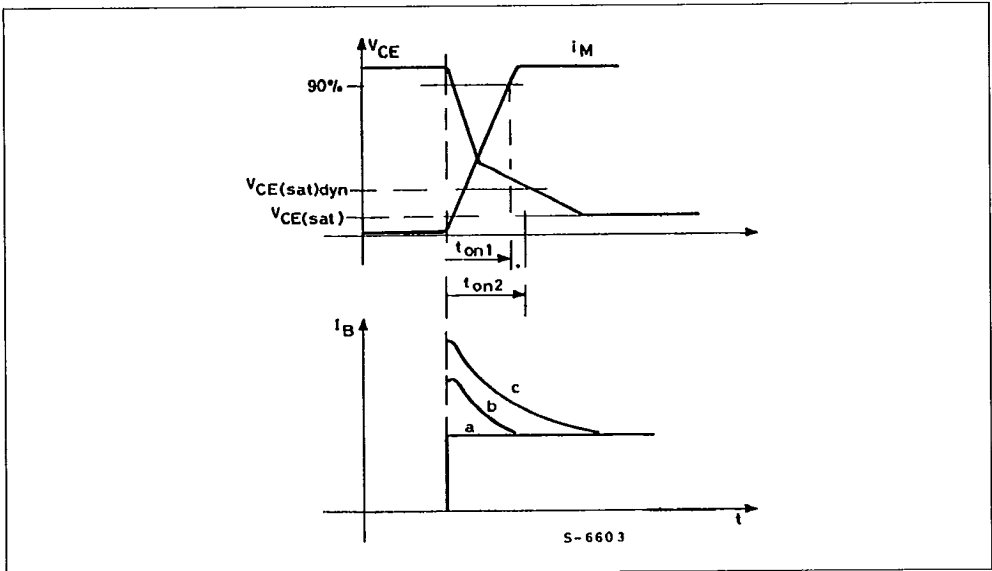

Figure 6 : Remarks to  $V_{CE(sat)}$  Dyn. Test Circuit (fig. 4).



The speed-up capacitor decreases the  $V_{CE(sat)}$  dyn. as shown in diagram (figure 6). The 50 nF capacitor modifies the shape of base current with a overshoot.

S G S-THOMSON

30E D

7929237 0028989 5

T-33-13

**ISOWATT218 PACKAGE CHARACTERISTICS AND APPLICATION**

ISOWATT218 is fully isolated to 4000V dc. Its thermal impedance, given in the data sheet, is optimized to give efficient thermal conduction together with excellent electrical isolation. The structure of the case ensures optimum distances between the pins and heatsink. These distances are in agreement with VDE and UL creepage and clearance standards. The ISOWATT218 package eliminates the need for external isolation so reducing fixing hardware.

The package is supplied with leads longer than the standard TO-218 to allow easy mounting on pcbs.

Accurate moulding techniques used in manufacture assures consistent heat spreader-to-heatsink capacitance.

ISOWATT218 thermal performance is equivalent to that of the standard part, mounted with a 0.1mm mica washer. The thermally conductive plastic has a higher breakdown rating and is less fragile than mica or plastic sheets. Power derating for ISOWATT218 packages is determined by :

$$P_D = \frac{T_j - T_c}{R_{th}}$$

**THERMAL IMPEDANCE OF ISOWATT218 PACKAGE**

Fig. 7 illustrates the elements contributing to the thermal resistance of a transistor heatsink assembly, using ISOWATT218 package.

The total thermal resistance  $R_{th(tot)}$  is the sum of each of these elements. The transient thermal impedance,  $Z_{th}$  for different pulse durations can be estimated as follows :

1 - For a short duration power pulse of less than 1ms :

$$Z_{th} < R_{thJ-C}$$

2 - For an intermediate power pulse of 5ms to 50ms seconds :

$$Z_{th} = R_{thJ-C}$$

3 - For long power pulses of the order of 500ms seconds or greater :

$$Z_{th} = R_{thJ-C} + R_{thC-HS} + R_{thHS-amb}$$

It is often possible to discern these areas on transient thermal impedance curves.

Figure 7.

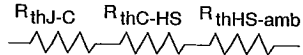

SGS-THOMSON

3OE D

This datasheet has been downloaded from:

[www.DatasheetCatalog.com](http://www.DatasheetCatalog.com)

Datasheets for electronic components.



LittleDiode supplies new, hard to find or obsolete electronic components and semiconductors all over the world.

With over two million different components listed you are sure to find the part you need.

Feel free to visit us today at our online store:

[LittleDiode.com](http://LittleDiode.com)

Looking forward to providing you with the best possible service.