

CATV-MATV AMPLIFIERS

DESCRIPTION

The BFW 16A and BFW 17A are multi-emitter silicon planar epitaxial NPN transistors in Jedec TO-39 metal case, with extremely good intermodulation properties and high power gain. They are primarily intended for final and driver stages in channel-and band-aerial amplifiers with high output power from 40 to 860 MHz.

Another possible application is as the final stage of the wide band vertical amplifier in high speed oscilloscopes.

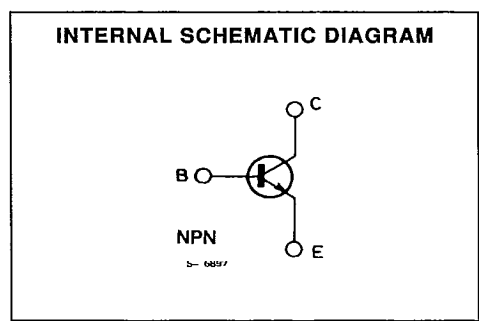
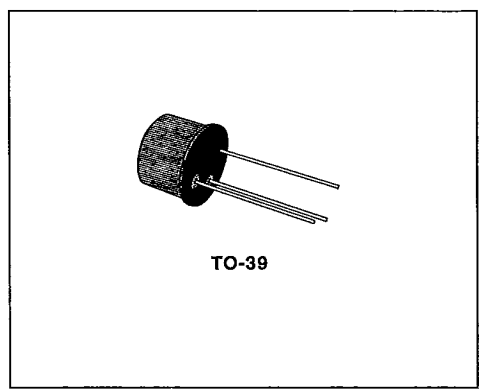

ABSOLUTE MAXIMUM RATINGS

Symbol	Parameter	Value	Unit
V _{CB0}	Collector-base Voltage (I _E = 0)	40	V
V _{CER}	Collector-emitter Voltage (R _{BE} ≤ 50 Ω)	40	V
V _{CEO}	Collector-emitter Voltage (I _B = 0)	25	V
V _{EBO}	Emitter-base Voltage (I _C = 0)	3	V
I _C	Collector Current	150	mA
I _{CM}	Collector Peak Current	300	mA
P _{tot}	Total Power Dissipation at T _{amb} ≤ 25 °C at T _{case} ≤ 125 °C	0.7	W
		1.5	W
T _{stg} , T _J	Storage and Junction Temperature	- 65 to 200	°C

THERMAL DATA

$R_{th\ j-case}$	Thermal Resistance Junction-case	Max	50	°C/W
$R_{th\ j-amb}$	Thermal Resistance Junction-ambient	Max	250	°C/W

ELECTRICAL CHARACTERISTICS ($T_{amb} = 25\text{ °C}$ unless otherwise specified)

Symbol	Parameter	Test Conditions	Min.	Typ.	Max.	Unit
I_{CBO}	Collector Cutoff Current ($I_E = 0$)	$V_{CB} = 20\text{ V}$ $T_{amb} = 150\text{ °C}$			20	μA
$V_{(BR)EBO}$	Emitter-base Breakdown Voltage ($I_C = 0$)	$I_E = 100\ \mu\text{A}$	3			V
$V_{CEK}^{*/**}$	Collector-emitter Knee Voltage	$I_C = 100\text{ mA}$			0.75	V
h_{FE}^*	DC Current Gain	$I_C = 50\text{ mA}$ $V_{CE} = 5\text{ V}$ $I_C = 150\text{ mA}$ $V_{CE} = 5\text{ V}$	25 25			
f_T	Transition Frequency	$I_C = 150\text{ mA}$ $V_{CE} = 15\text{ V}$ $f = 500\text{ MHz}$ for BFW 16A for BFW 17A		1.2 1.1		GHz GHz
C_{CBO}	Collector-base Capacitance	$I_E = 0$ $V_{CB} = 15\text{ V}$ $f = 1\text{ MHz}$			4	pF
C_{re}	Reverse Capacitance	$I_C = 10\text{ mA}$ $V_{CE} = 15\text{ V}$ $f = 1\text{ MHz}$		1.7		pF
NF	Noise Figure (for BFW 16A only)	$I_C = 30\text{ mA}$ $V_{CE} = 15\text{ V}$ $R_g = 75\ \Omega$ $f = 200\text{ MHz}$			6	dB
G_{pe}	Power Gain (not neutralized)	$I_C = 70\text{ mA}$ $V_{CE} = 18\text{ V}$ $f = 200\text{ MHz}$ for BFW 16A and BFW 17A $f = 800\text{ MHz}$ For BFW 16A only		16 6.5		dB dB
P_0	Output Power	$I_C = 70\text{ mA}$ $V_{CE} = 18\text{ V}$ Channel 9 ⁽¹⁾ for BFW 16A for BFW 17A Channel 62 ⁽²⁾ For BFW 16A only	130 70	150 150 90		mW mW mW

* Pulsed : pulse duration = 300 μs , duty cycle = 1 %.

** I_B = value for which $I_C = 110\text{ mA}$ at $V_{CE} = 1\text{ V}$.

(1) $f_p = 202\text{ MHz}$, $f_q = 205\text{ MHz}$, $f_{(2q-p)} = 208\text{ MHz}$.

(2) $f_p = 798\text{ MHz}$, $f_q = 802\text{ MHz}$, $f_{(2q-p)} = 806\text{ MHz}$.

TEST CIRCUIT

Test Circuit for Power Gain and Output Power Measurements ($f = 200$ MHz).

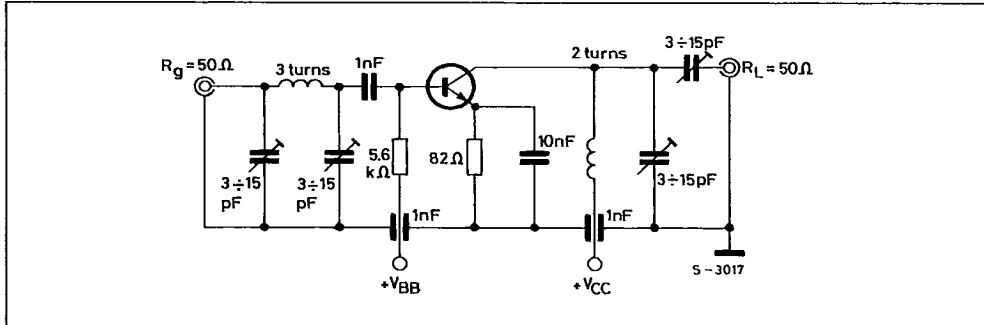

High Frequency Current Gain.

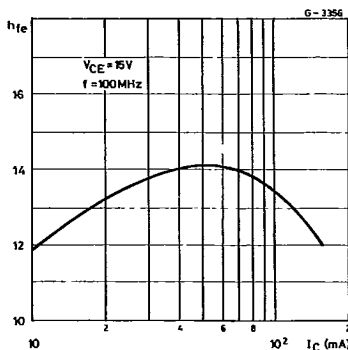

Reverse Capacitance.

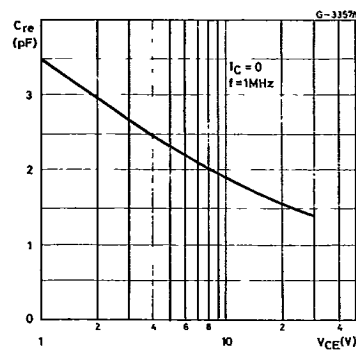

Input Impedance S_{11e} (normalized 50 Ω).

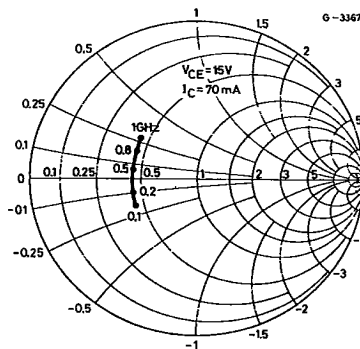

Forward Transfer Coefficient S_{21e} .

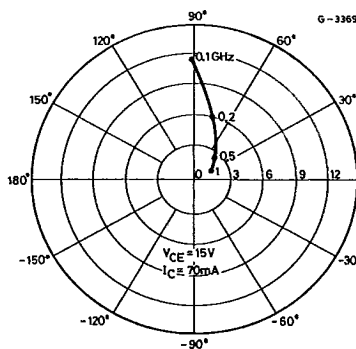

30E D ■ 7929237 0030972 9 ■

Reverse Transfer Coefficient S_{12e} .

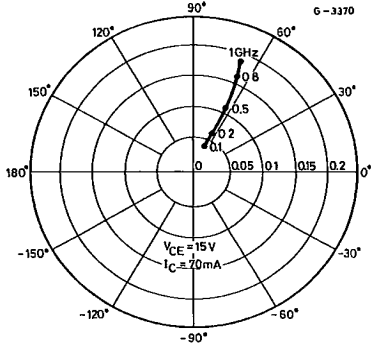

Output Impedance S_{22e} (normalized 50 Ω).

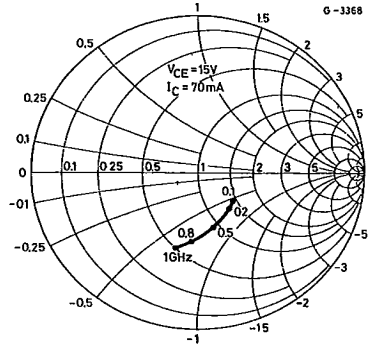

This datasheet has been downloaded from:

www.DatasheetCatalog.com

Datasheets for electronic components.



LittleDiode supplies new, hard to find or obsolete electronic components and semiconductors all over the world.

With over two million different components listed you are sure to find the part you need.

Feel free to visit us today at our online store:

LittleDiode.com

Looking forward to providing you with the best possible service.