



### N-Channel JFETs

PRODUCT SUMMARY						
Part Number	V <sub>GS(off)</sub> (V)	V <sub>(BR)GSS</sub> Min (V)	I <sub>DSS</sub> Min (mA)	r <sub>DS(on)</sub> Max (Ω)	I <sub>D(off)</sub> Typ (pA)	t <sub>ON</sub> Typ (ns)
2N4856A	-4 to -10	-40	50	25	5	4
2N4857A	-2 to -6	-40	20	40	5	4
2N4858A	-0.8 to -4	-40	8	60	5	4

#### FEATURES

- Low On-Resistance: 2N4856A <25 Ω
- Fast Switching—t<sub>ON</sub>: 4 ns
- High Off-Isolation—I<sub>D(off)</sub>: 5 pA
- Low Capacitance: 3 pF
- Low Insertion Loss

#### BENEFITS

- Low Error Voltage
- High-Speed Analog Circuit Performance
- Negligible "Off-Error," Excellent Accuracy
- Good Frequency Response
- Eliminates Additional Buffering

#### APPLICATIONS

- Analog Switches
- Choppers
- Sample-and-Hold
- Normally "On" Switches
- Current Limiters

#### DESCRIPTION

The 2N4856A/4857A/4858A all-purpose JFET analog switches offer low on-resistance, low capacitance, good isolation, and fast switching.

Hermetically-sealed TO-206AA (TO-18) packaging allows full military processing (see Military Information). For similar products in TO-226AA (TO-92) and SOT-23 packages, see the J/SST111 series data sheet. For similar duals, see the 2N5564/5565/5566 data sheet.

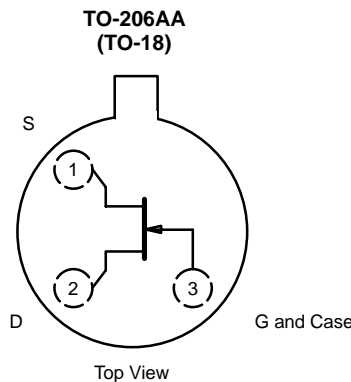



### ABSOLUTE MAXIMUM RATINGS

Gate-Drain, Gate-Source Voltage : (2N4856A-58A) ..... -40 V  
 Gate Current ..... 50 mA  
 Lead Temperature ( $1/16$ " from case for 10 seconds) ..... 300 °C  
 Storage Temperature ..... -65 to 200 °C

Operating Junction Temperature ..... -55 to 200 °C  
 Power Dissipation<sup>a</sup> ..... 1.8 W

#### Notes

a. Derate 10 mW/°C for  $T_C > 25$  °C

SPECIFICATIONS ( $T_A = 25$ °C UNLESS OTHERWISE NOTED)											
Parameter	Symbol	Test Conditions	Typ <sup>a</sup>	Limits						Unit	
				2N4856A		2N4857A		2N4858A			
				Min	Max	Min	Max	Min	Max		
<b>Static</b>											
Gate-Source Breakdown Voltage	$V_{(BR)GSS}$	$I_G = -1 \mu A, V_{DS} = 0 V$	-55	-40		-40		-40		V	
Gate-Source Cutoff Voltage	$V_{GS(off)}$	$V_{DS} = 15 V, I_D = 0.5 nA$		-4	-10	-2	-6	-0.8	-4		
Saturation Drain Current <sup>b</sup>	$I_{DSS}$	$V_{DS} = 15 V, V_{GS} = 0 V$		50		20	100	8	80	mA	
Gate Reverse Current	$I_{GSS}$	$V_{GS} = -20 V, V_{DS} = 0 V$		-5		-250		-250		-250	pA
			$T_A = 150$ °C	-13		-500		-500		-500	nA
Gate Operating Current <sup>c</sup>	$I_G$	$V_{DG} = 15 V, I_D = 10 mA$	-5							pA	
Drain Cutoff Current	$I_{D(off)}$	$V_{DS} = 15 V, V_{GS} = -10 V$		5		250		250		250	pA
			$T_A = 150$ °C	13		500		500		500	nA
Drain-Source On-Voltage	$V_{DS(on)}$	$V_{GS} = 0 V$	$I_D = 5 mA$	0.25					0.5		V
			$I_D = 10 mA$	0.35			0.5				
			$I_D = 20 mA$	0.5		0.75					
Drain-Source On-Resistance <sup>c</sup>	$r_{DS(on)}$	$V_{GS} = 0 V, I_D = 1 mA$			25		40		60	Ω	
Gate-Source Forward Voltage <sup>c</sup>	$V_{GS(F)}$	$I_G = 1 mA, V_{DS} = 0 V$	0.7							V	
<b>Dynamic</b>											
Common-Source Forward Transconductance <sup>c</sup>	$g_{fs}$	$V_{DS} = 20 V, I_D = 1 mA$ $f = 1 kHz$	6							mS	
	$g_{os}$		25							μS	
Drain-Source On-Resistance	$r_{ds(on)}$	$V_{GS} = 0 V, I_D = 0 mA$ $f = 1 kHz$			25		40		60	Ω	
Common-Source Input Capacitance	$C_{iss}$	$V_{DS} = 0 V, V_{GS} = -10 V$ $f = 1 MHz$	7		10		10		10	pF	
Common-Source Reverse Transfer Capacitance	$C_{rss}$		3		4		3.5		3.5		
Equivalent Input Noise Voltage <sup>c</sup>	$\bar{e}_n$	$V_{DS} = 10 V, I_D = 10 mA$ $f = 1 kHz$	3							nV/ √Hz	
<b>Switching</b>											
Turn-On Time	$t_{d(on)}$	$V_{DD} = 10 V, V_{GSH} = 0 V$ See Switching Circuit	2		5		6		8	ns	
	$t_r$		2		3		4		8		
Turn-Off Time	$t_{OFF}$		12		20		40		80		

#### Notes

- a. Typical values are for DESIGN AID ONLY, not guaranteed nor subject to production testing.
- b. Pulse test:  $PW \leq 100 \mu s$  duty cycle  $\leq 10\%$ .
- c. This parameter not registered with JEDEC.

NCB



**TYPICAL CHARACTERISTICS (T<sub>A</sub> = 25°C UNLESS OTHERWISE NOTED)**

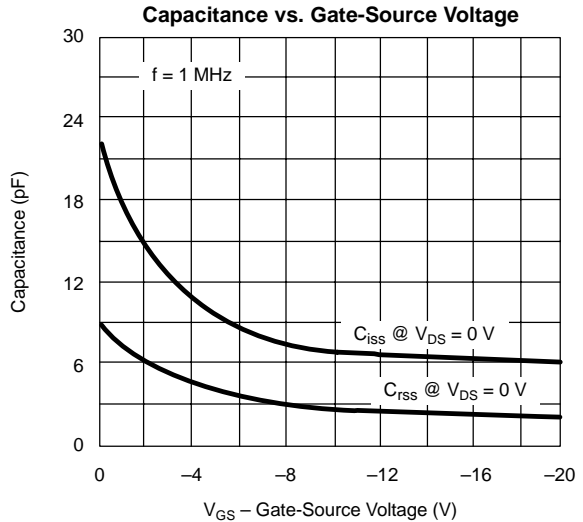
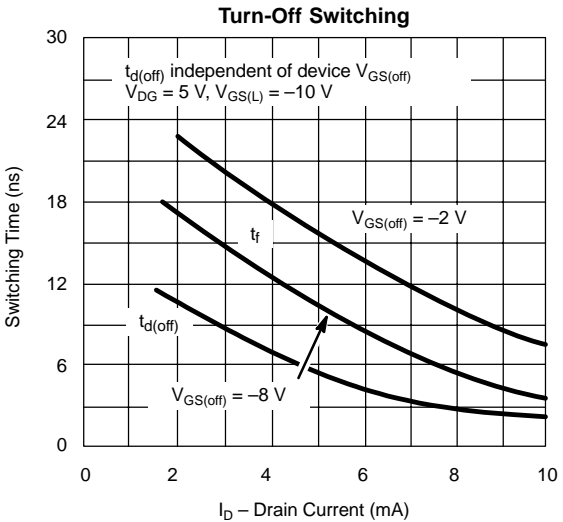
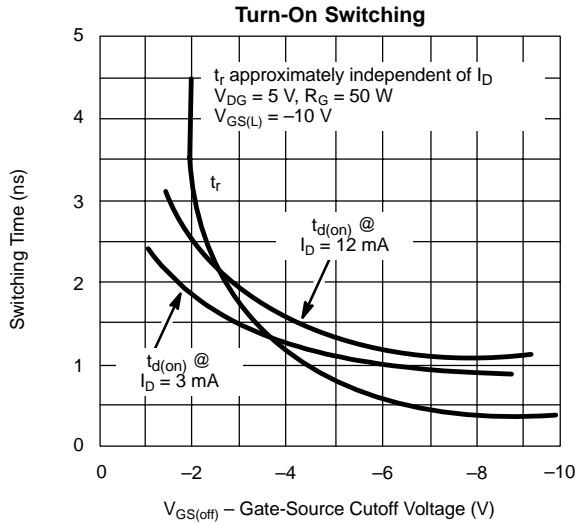
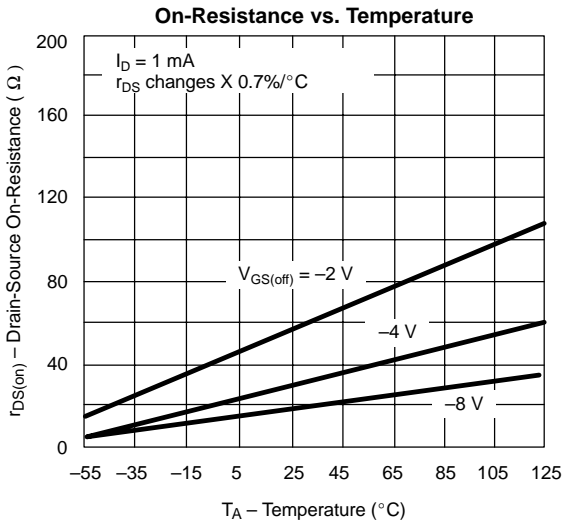
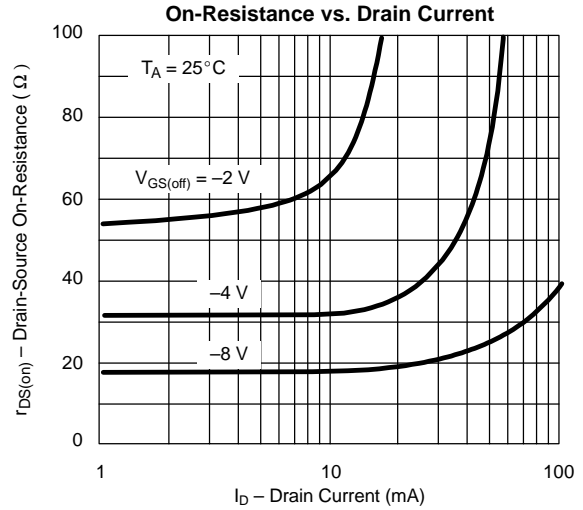
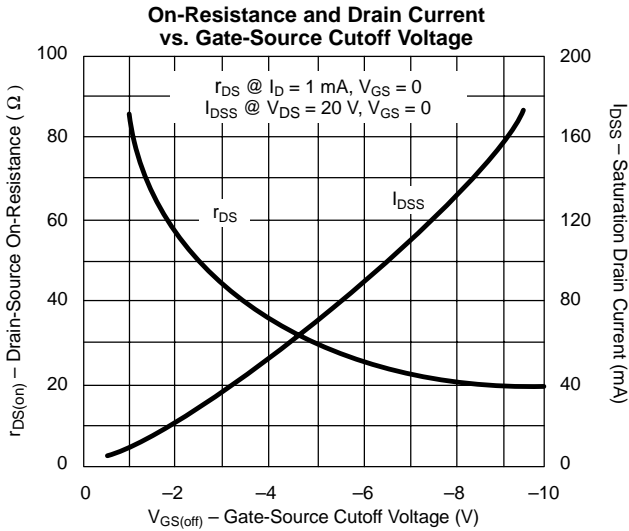

**TYPICAL CHARACTERISTICS (T<sub>A</sub> = 25°C UNLESS OTHERWISE NOTED)**

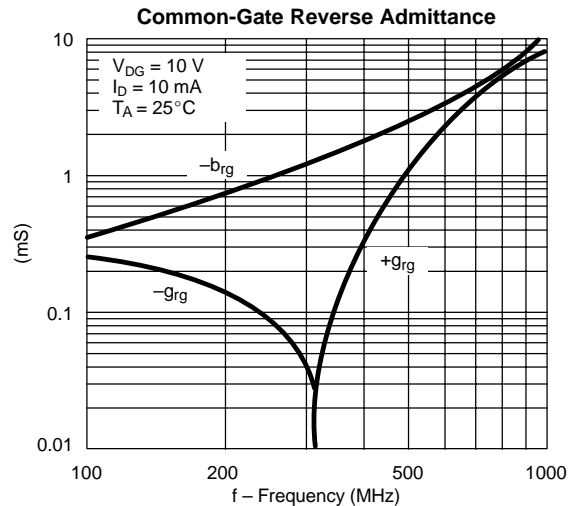
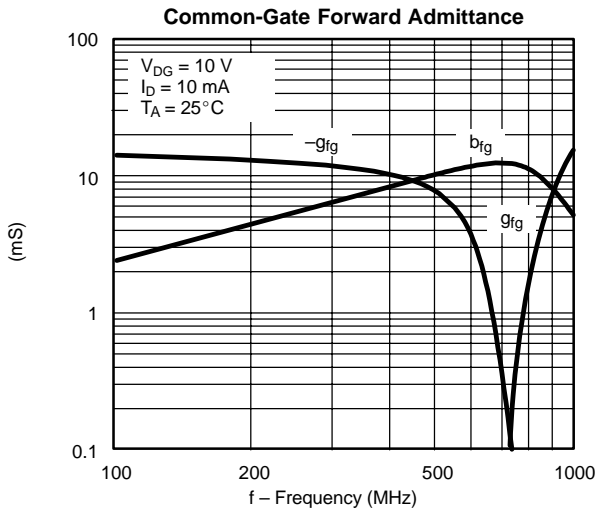
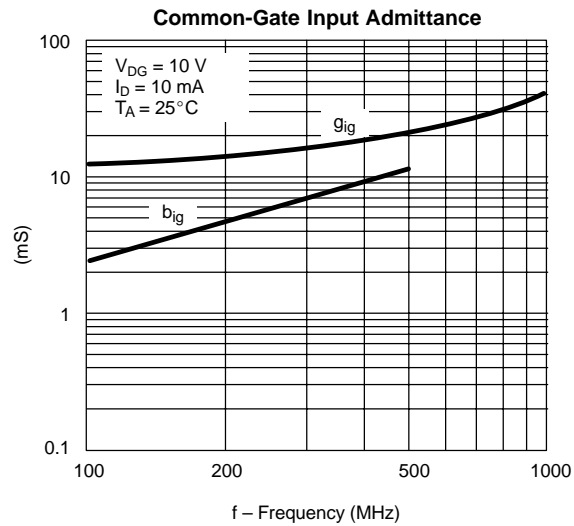
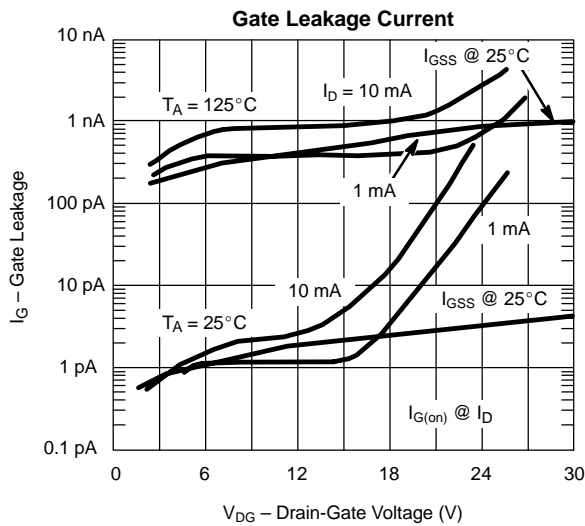
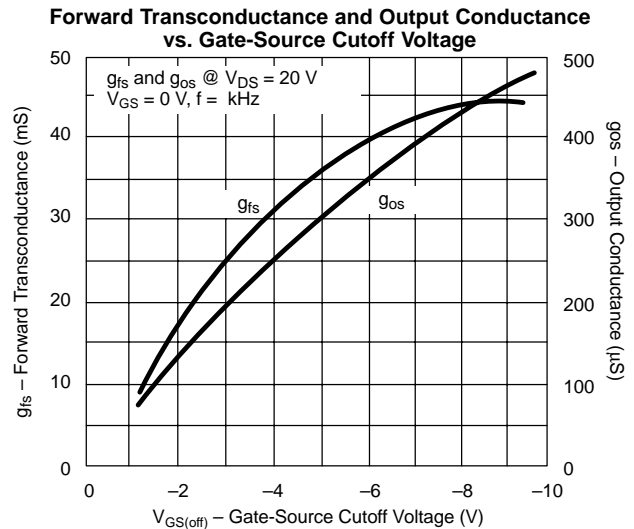
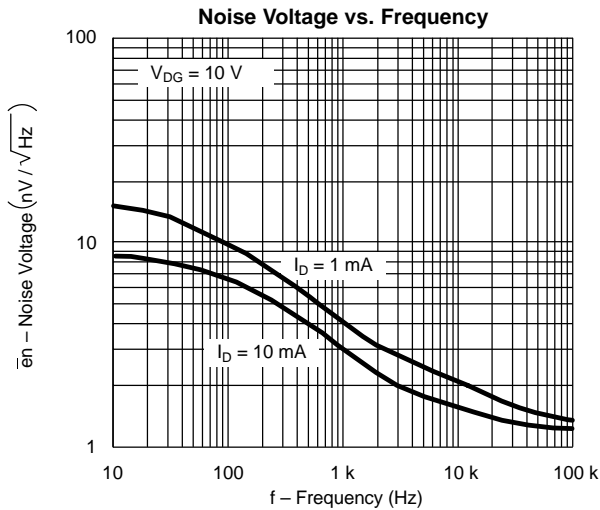



**TYPICAL CHARACTERISTICS (T<sub>A</sub> = 25°C UNLESS OTHERWISE NOTED)**

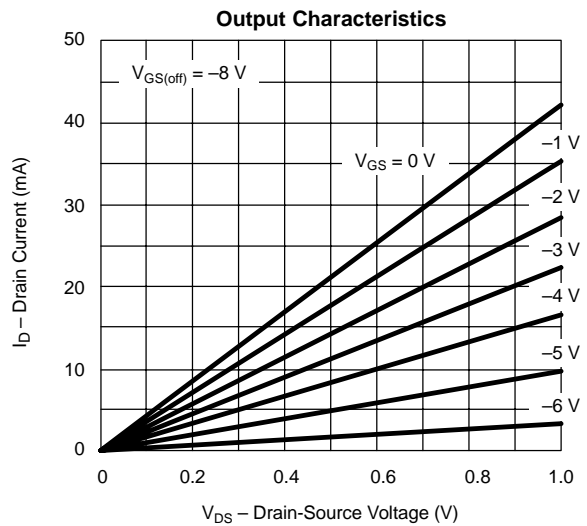
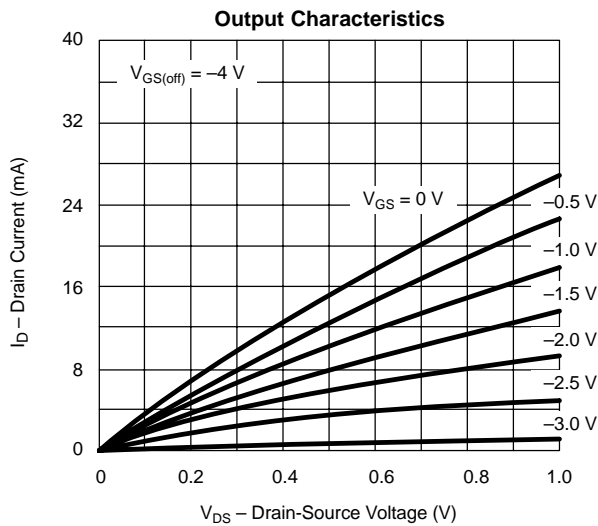
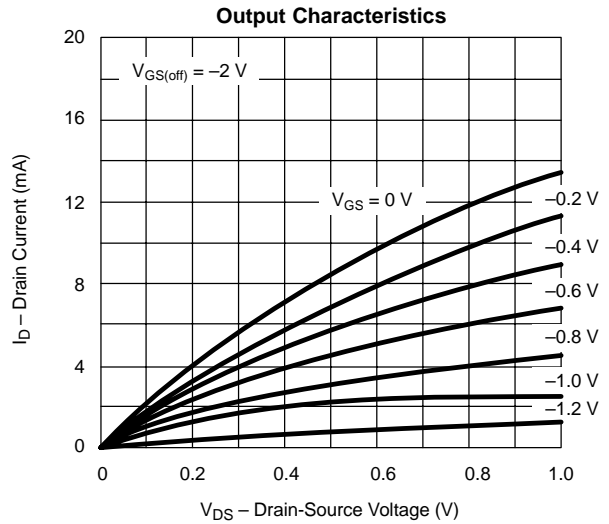
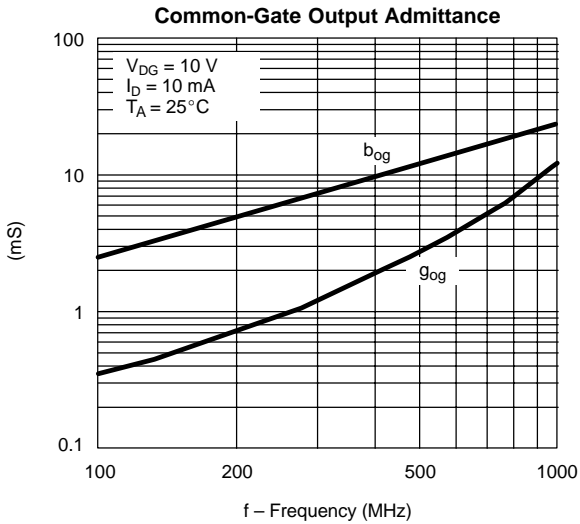

<b>SWITCHING TIME TEST CIRCUIT</b>			
	2N4856A	2N4857A	2N4858A
$V_{GS(L)}$	-10 V	-6 V	-4 V
$R_L^*$	464 $\Omega$	953 $\Omega$	1910 $\Omega$
$I_{D(on)}$	20 mA	10 mA	5 mA

\*Non-inductive

**INPUT PULSE**

Rise Time < 1 ns  
 Fall Time < 1 ns  
 Pulse Width 100 ns  
 PRF 1 MHz

**SAMPLING SCOPE**

Rise Time 0.4 ns  
 Input Resistance 10 M $\Omega$   
 Input Capacitance 1.5 pF

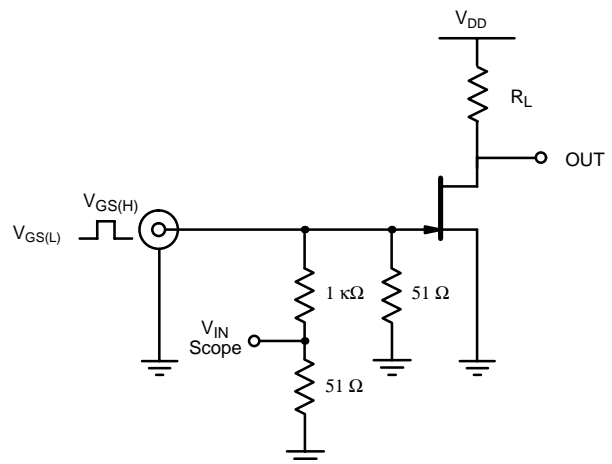



LittleDiode supplies new, hard to find or obsolete electronic components and semiconductors all over the world.

With over two million different components listed you are sure to find the part you need.

Feel free to visit us today at our online store:

[LittleDiode.com](http://LittleDiode.com)

Looking forward to providing you with the best possible service.