

SILICON NPN TRANSISTOR

- STMicroelectronics PREFERRED SALESTYPE
- NPN TRANSISTOR

DESCRIPTION

The BFX34 is a silicon Epitaxial Planar NPN transistor in Jedec TO-39 metal case, intended for high current applications.

Very low saturation voltage and high speed at high current levels make it ideal for power drivers, power amplifiers, switching power supplies and relay drivers inverters.

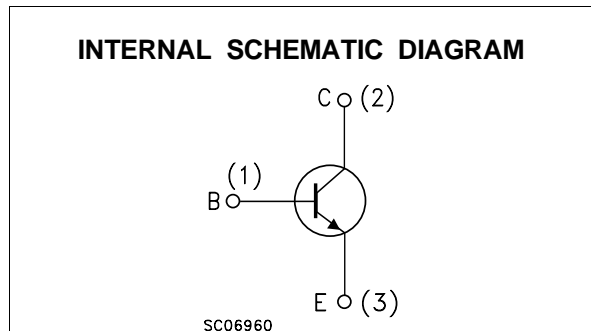
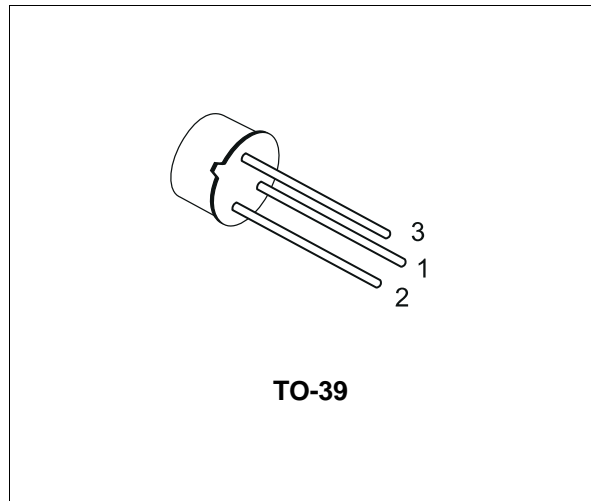

ABSOLUTE MAXIMUM RATINGS

Symbol	Parameter	Value	Unit
V_{CBO}	Collector-Base Voltage ($I_E = 0$)	120	V
V_{CEO}	Collector-Emitter Voltage ($I_B = 0$)	60	V
V_{EBO}	Emitter-Base Voltage ($I_C = 0$)	6	V
I_C	Collector Current	5	A
P_{tot}	Total Dissipation at $T_{case} \leq 25\text{ }^\circ\text{C}$ $T_{amb} \leq 25\text{ }^\circ\text{C}$	5	W
		0.87	W
T_{stg}	Storage Temperature	-65 to 200	$^\circ\text{C}$
T_j	Max. Operating Junction Temperature	200	$^\circ\text{C}$

BFX34

THERMAL DATA

R _{thj-case}	Thermal Resistance Junction-case	Max	35	°C/W
R _{thj-amb}	Thermal Resistance Junction-amb	Max	200	°C/W

ELECTRICAL CHARACTERISTICS (T_{case} = 25 °C unless otherwise specified)

Symbol	Parameter	Test Conditions	Min.	Typ.	Max.	Unit
I _{CES}	Collector Cut-off Current (V _{BE} = 0)	V _{CE} = 60 V		0.02	10	μA
I _{EBO}	Emitter Cut-off Current (I _C = 0)	V _{EB} = 4 V		0.05	10	μA
V _{(BR)CBO} *	Collector-base Breakdown Voltage (I _E = 0)	I _C = 5 mA	120			V
V _{CEO(sus)} *	Collector-Emitter Sustaining Voltage (I _B = 0)	I _C = 100 mA	60			V
V _{EBO} *	Emitter-base Voltage (I _C = 0)	I _E = 1 mA	6			V
V _{CE(sat)} *	Collector-Emitter Saturation Voltage	I _C = 5 A I _B = 0.5 A		0.4	1	V
V _{BE(sat)} *	Base-Emitter Saturation Voltage	I _C = 5 A I _B = 0.5 A		1.3	1.6	V
h _{FE} *	DC Current Gain	I _C = 1 A V _{CE} = 2 V I _C = 1.5 A V _{CE} = 0.6 V I _C = 2 A V _{CE} = 2 V	40	100 75 80	150	
f _T *	Transition Frequency	I _C = 0.5 A V _{CE} = 5 V f = 20 MHz	70	100		MHz
C _{EBO}	Emitter-base Capacitance	I _C = 0 V _{EB} = 0.5 V f = 1 MHz		300	500	pF
C _{CBO}	Collector-base Capacitance	I _E = 0 V _{CB} = 10 V f = 1 MHz		40	100	pF
t _{on} t _{off}	RESISTIVE LOAD Turn-on Time Turn-off Time	I _C = 0.5 A V _{CC} = 20 V I _{B1} = -I _{B2} = 0.5 A		0.6 0.6	0.25 1.2	μs μs

* Pulsed: Pulse duration = 300 μs, duty cycle 1.5 %

TO-39 MECHANICAL DATA

DIM.	mm			inch		
	MIN.	TYP.	MAX.	MIN.	TYP.	MAX.
A	12.7			0.500		
B			0.49			0.019
D			6.6			0.260
E			8.5			0.334
F			9.4			0.370
G	5.08			0.200		
H			1.2			0.047
I			0.9			0.035
L	45° (typ.)					

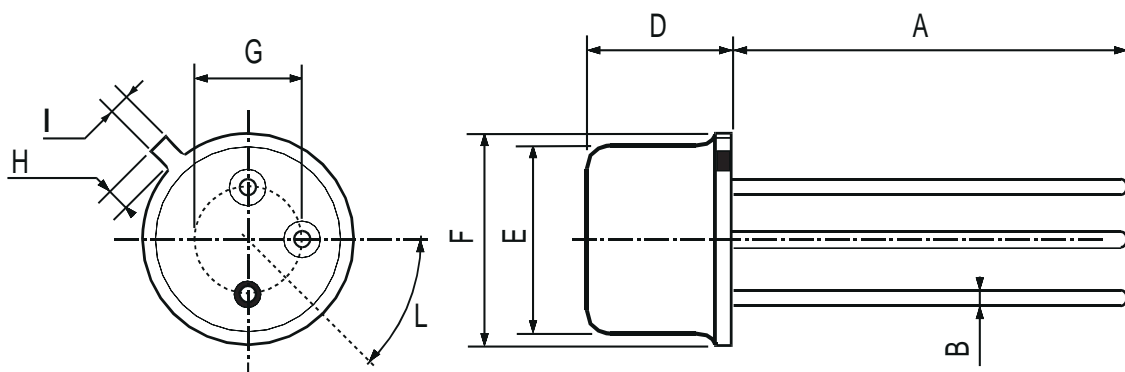

P008B

Information furnished is believed to be accurate and reliable. However, STMicroelectronics assumes no responsibility for the consequences of use of such information nor for any infringement of patents or other rights of third parties which may result from its use. No license is granted by implication or otherwise under any patent or patent rights of STMicroelectronics. Specification mentioned in this publication are subject to change without notice. This publication supersedes and replaces all information previously supplied. STMicroelectronics products are not authorized for use as critical components in life support devices or systems without express written approval of STMicroelectronics.

The ST logo is a trademark of STMicroelectronics

© 2001 STMicroelectronics – Printed in Italy – All Rights Reserved

STMicroelectronics GROUP OF COMPANIES

Australia - Brazil - China - Finland - France - Germany - Hong Kong - India - Italy - Japan - Malaysia - Malta - Morocco - Singapore - Spain - Sweden - Switzerland - United Kingdom - U.S.A.

<http://www.st.com>



LittleDiode supplies new, hard to find or obsolete electronic components and semiconductors all over the world.

With over two million different components listed you are sure to find the part you need.

Feel free to visit us today at our online store:

LittleDiode.com

Looking forward to providing you with the best possible service.