

DESCRIPTION

Monolithic Darlingtons with integrated speed-up and damper diode, suited for TV applications.

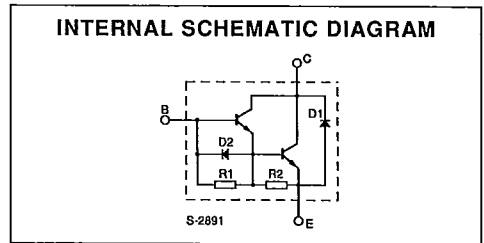
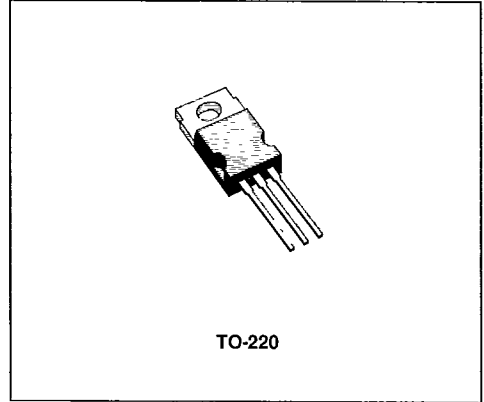

ABSOLUTE MAXIMUM RATINGS

Symbol	Parameter	Value		Unit
		BU184	BU189	
V _{CB0}	Collector-base Voltage (I _E = 0)	400	330	V
V _{CEx}	Collector-emitter Voltage	400	330	V
V _{CE0}	Collector-emitter Voltage (I _B = 0)	200	150	V
V _{EB0}	Emitter-base Voltage (I _C = 0)	8		V
I _C	Collector Current	8		A
I _{CM}	Collector Peak Current (t _p < 10ms)	15		A
I _B	Base Current	2		A
I _{BM}	Base Peak Current (t _p < 10ms)	4		A
P _{tot}	Total Dissipation at T _c < 25°C	60		W
T _{stg}	Storage Temperature	- 65 to + 150		°C
T _j	Max. Operating Junction Temperature	150		°C

THERMAL DATA

S G S-THOMSON

30E D

$R_{th\ j-case}$	Thermal Resistance Junction-case	Max	2.08	°C/W
------------------	----------------------------------	-----	------	------

ELECTRICAL CHARACTERISTICS ($T_{case} = 25^{\circ}C$ unless otherwise specified)

Symbol	Parameter	Test Conditions	Min.	Typ.	Max.	Unit
I_{CEX}	Collector Cutoff Current	$V_{CE} = V_{CEX}$ $V_{BE} = -6V$			100	μA
I_{EBO}	Emitter Cutoff Current ($I_C = 0$)	$V_{EB} = -8V$			10	mA
$V_{CE(sus)}$	Collector Emitter Sustaining Voltage	$I_C = 3A$ $L = 15mH$ for BU184 for BU189	200 150			V V
$V_{CE(sat)}$	Collector-emitter Saturation Voltage	$I_C = 5A$ $I_B = 50mA$			1.5	V
$V_{BE(sat)}$	Base-emitter Saturation Voltage	$I_C = 5A$ $I_B = 50mA$			2.2	V
V_F	Diode Forward Voltage	$I_F = 4A$		1.8	2.3	V
t_s t_f	RESISTIVE LOAD Storage Time Fall Time	See Test Circuit		0.44 0.3	0.5	μs μs

* Pulse test $t_p < 300 \mu s$ $\delta < 2 \%$.

TEST CIRCUIT

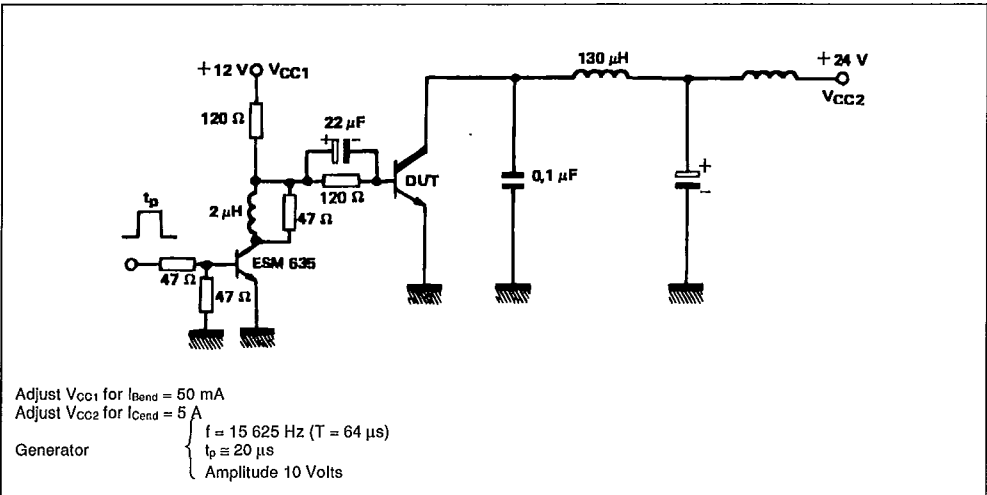

DC and Pulse Area.

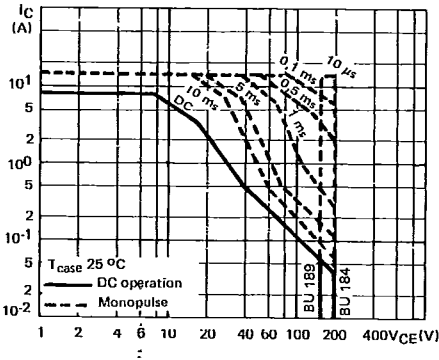

Collector-emitter Voltage vs Base-emitter Resistance.

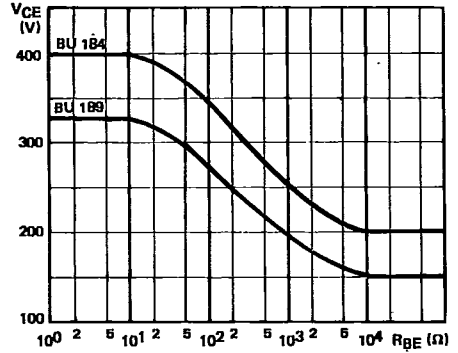

Power and IS/B Derating vs Case Temperature.

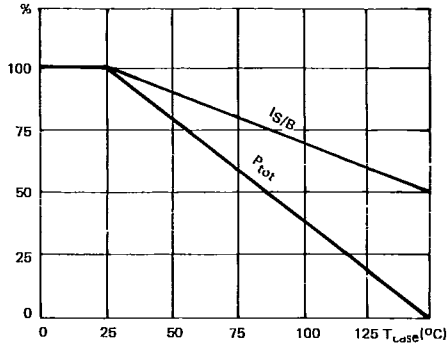

Transient Thermal Response.

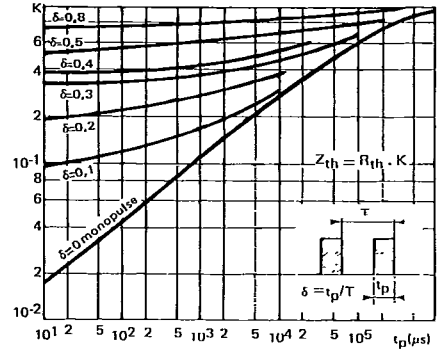

DC Current Gain.

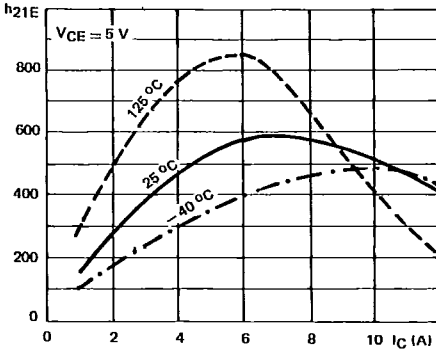

Saturation Voltage.

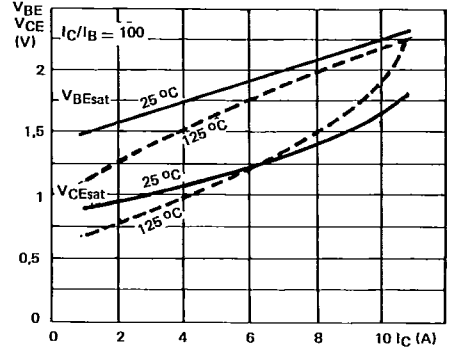

SGS-THOMSON

30E D

Base Characteristics.

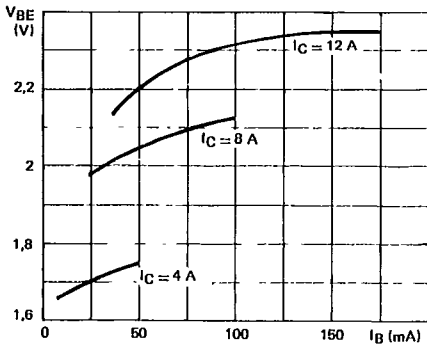

Collector Saturation Region.

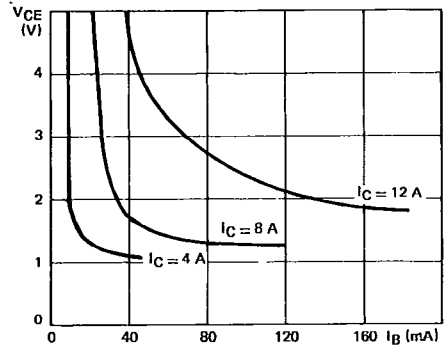

SGS-THOMSON

30E D

This datasheet has been downloaded from:

www.DatasheetCatalog.com

Datasheets for electronic components.



LittleDiode supplies new, hard to find or obsolete electronic components and semiconductors all over the world.

With over two million different components listed you are sure to find the part you need.

Feel free to visit us today at our online store:

LittleDiode.com

Looking forward to providing you with the best possible service.