

SURFACE MOUNT ESD SUPPRESSORS

8-Line CA10 **Obsoleted Part. Please consider PGB0010603, PGB002ST23 or PGB0040805 for new designs.**

PRODUCT OVERVIEW

PulseGuard ESD Suppressors help protect sensitive electronic equipment against electrostatic discharge (ESD). They supplement the on-chip protection of integrated circuitry and are best suited for low-voltage, high-speed applications where low capacitance is important. Applications such as computer I/O ports (eg. video displays), network hardware, cell phone data ports, point-of-sale terminals, and industrial controls will benefit from this new technology. PulseGuard suppressors use polymer composite materials to suppress fast-rising ESD transients (as specified in IEC 61000-4-2 and MIL-STD-883E).

FEATURES

- Ultra-low capacitance
- Low leakage current
- Fast response time
- Bi-directional
- Withstands multiple ESD strikes
- Packaged in chip array (capacitor/resistor) format
- Compatible with pick-and-place processes
- Available on 2,000 piece reels (EIA-RS481)

TYPICAL APPLICATIONS

- Computer I/O ports (e.g. video displays)
- Computer peripherals
- Network hardware/ports (e.g. Gigabit Ethernet)
- Point-of-Sale terminals
- Cell phone data ports
- Audio/video components
- Test Equipment
- Medical Equipment

ELECTRICAL CHARACTERISTICS

Trigger Voltage ¹	1,000V, typical
Clamping Voltage ¹	150V, typical
Rated Voltage	24VDC, max
Capacitance ²	0.055pF
Response Time ¹	<1ns
Leakage Current ³	<1nA
ESD Pulse Withstand ¹	1,000 pulses, minimum

Notes:

1. 8 kV direct discharge method, per IEC 61000-4-2.
2. Measured at 1 MHz.
3. Measured at 6 VDC. Testing at fast ESD pulse rates (1-20Hz) may cause a change in leakage current performance (6µA, max).

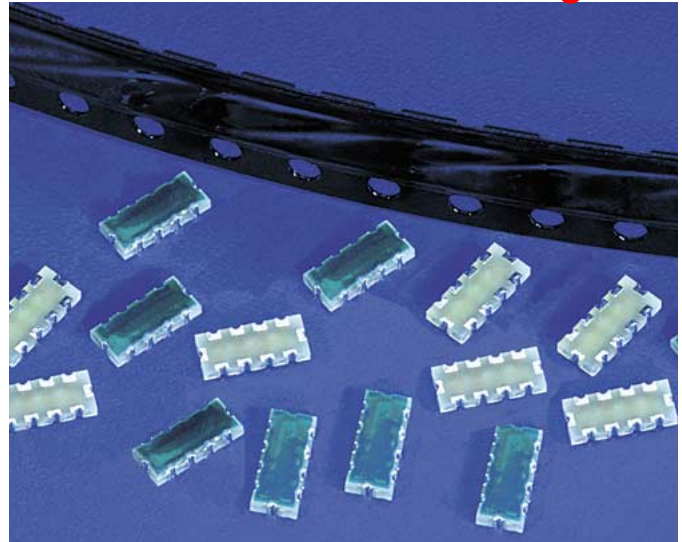

PHYSICAL SPECIFICATIONS

Materials:

Body: Glass Epoxy
Terminations: Tin-Lead

Soldering Parameters:

Wave solder -- 260°C, 10 seconds maximum
Reflow solder -- 260°C, 30 seconds maximum

Operating Temperature Range:

-65°C to +125°C

ORDERING INFORMATION

Catalog Number	Pieces per Reel
PGB008CA10PR	2,000

DESIGN CONSIDERATION

Because of the fast rise-time of the ESD transient, placement of PulseGuard suppressors is a key design consideration. To achieve optimal ESD suppression, the devices should be placed on the circuit board as close to the source of the ESD transient as possible. Install PulseGuard suppressors directly behind the connector so that they are the first board-level circuit component encountered by the ESD transient. They are connected from signal/data line to ground.

SURFACE MOUNT ESD SUPPRESSORS

8-Line CA10

Generalized PulseGuard Response to ESD
(Positive and Negative Polarity ESD Pulses)

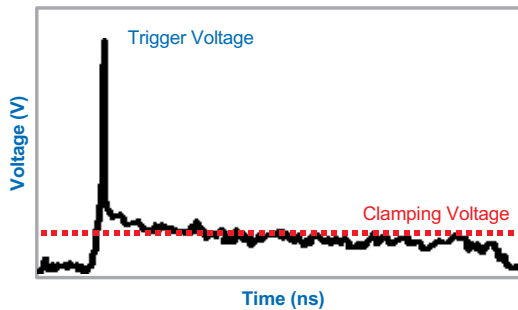

Generalized I-V Curve
(Positive and Negative Polarity ESD Pulses)

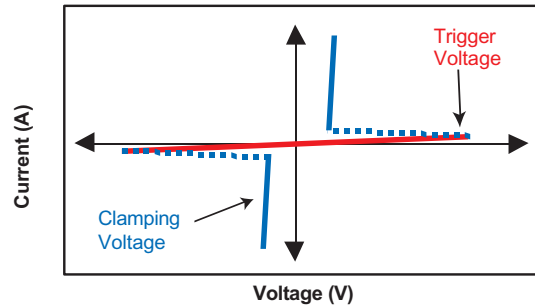

DEFINITIONS

Trigger Voltage: The measured peak voltage across the ESD suppressor before it transitions from high to low resistance. It is manifested as a “spike” before the clamping voltage is achieved. This voltage is typically well below the damage threshold of on-chip IC protection.

Clamping Voltage: The voltage level to which the ESD impulse voltage is reduced. This is the voltage that the suppressor holds at, until the ESD transient energy is dissipated.

ESD Impulse Voltage: Also known as the ESD Threat Voltage. This is the voltage that is “zapped” into the circuit. Voltages generated by people can exceed 15 kV. The IEC 61000-4-2 defines four levels of impulse voltage for testing purposes:

SEVERITY LEVEL	AIR DISCHARGE	DIRECT DISCHARGE
1	2 kV	2 kV
2	4 kV	4 kV
3	8 kV	6 kV
4	15 kV	8 kV

Capacitance vs. Frequency

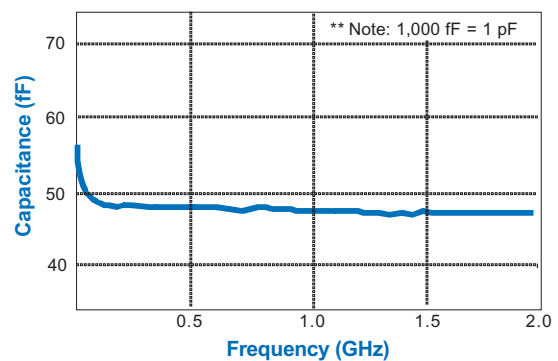

Carrier Tape Specifications

Parts are delivered on 7" (178mm) reel, plastic carrier tape

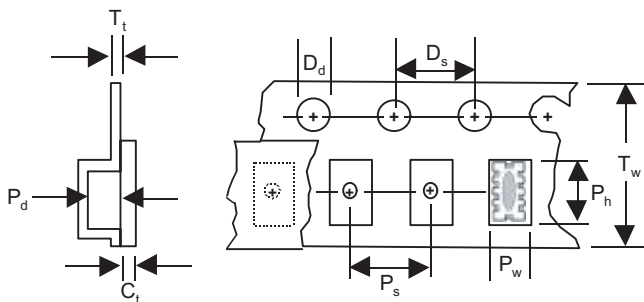

Description	Measurement (mm)
C _t - Cover tape thickness	0.06
D _d - Drive hole diameter	1.50
D _s - Drive hole spacing	4.00
P _d - Pocket depth	1.02
P _h - Pocket height	5.38
P _s - Pocket spacing	4.00
P _w - Pocket width	2.44
T _t - Carrier tape thickness	0.30
T _w - Carrier tape width	12.00

SURFACE MOUNT ESD SUPPRESSORS

8-Line CA10

Test Set-up for IEC 61000-4-2 Waveform, 2kV-15kV

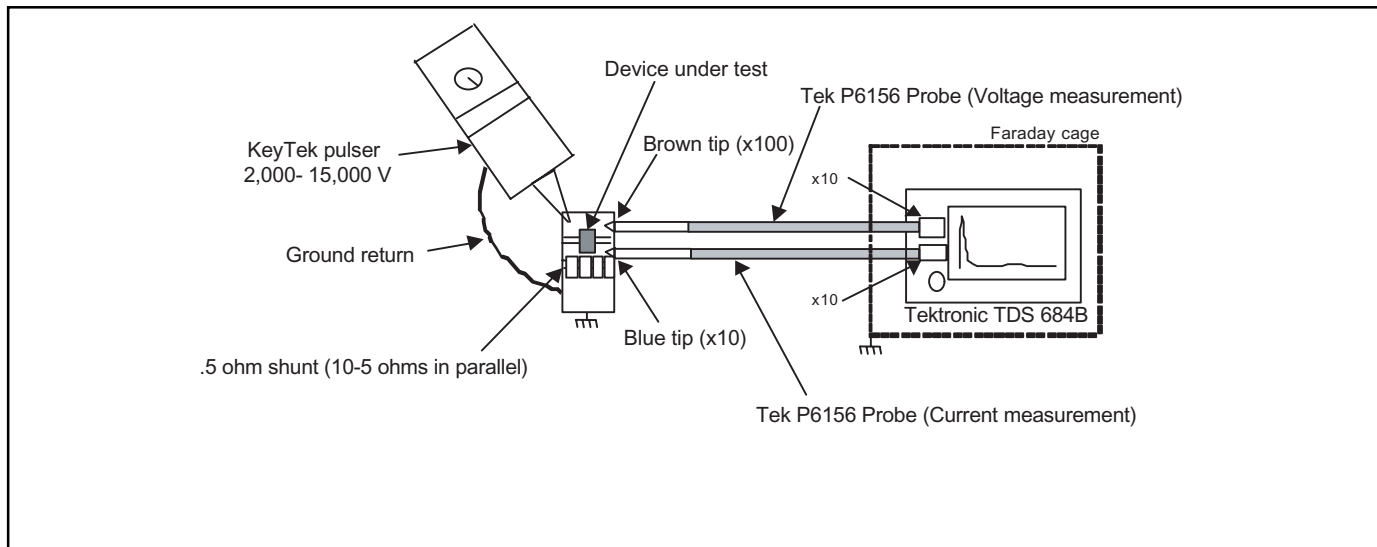

Reference Schematics:

Recommended Pad Layout:

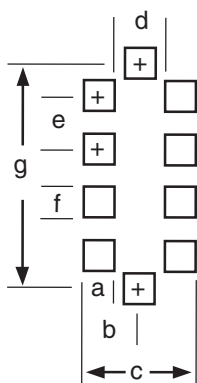

Device Dimensions:

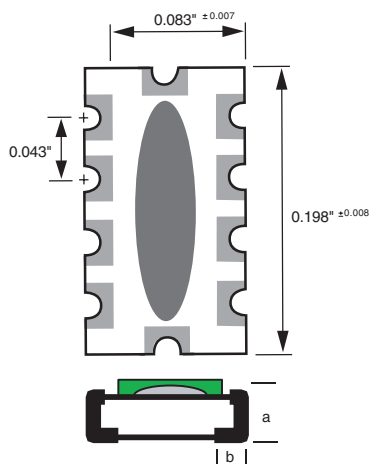

*Dimension 'a' is: 0.026"
*Dimension 'b' is: 0.015"

Equivalent Circuit:

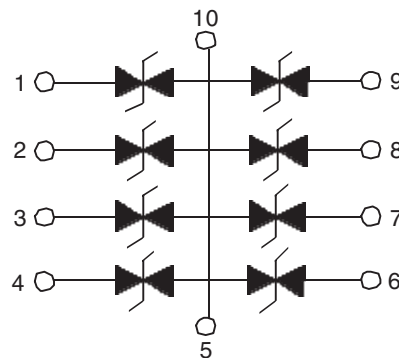

Pad Dimensions (in.)							
Solder Method	a	b	c	d	e	f	g
Wave Solder	0.036	0.060	0.119	0.047	0.043	0.030	0.198
Reflow Solder	0.025	0.050	0.101	0.051	0.043	0.030	0.191

Note: Pins 5 and 10 (Common) are typically connected to chassis ground. However since PulseGuard suppressors are bi-directional, the system voltage bus can also be used as the ESD "dump".



LittleDiode supplies new, hard to find or obsolete electronic components and semiconductors all over the world.

With over two million different components listed you are sure to find the part you need.

Feel free to visit us today at our online store:

LittleDiode.com

Looking forward to providing you with the best possible service.