

2N2221A

Features

- Meets MIL 19500 /255
- Collector - Base Voltage 75 V
- Collector - Current 800 mA
- High Speed, Medium Current Bipolar Transistor

SWITCHING
 TRANSISTOR
 JAN, JANTX, JANTXV

SMALL SIGNAL
 BIPOLAR
 NPN SILICON

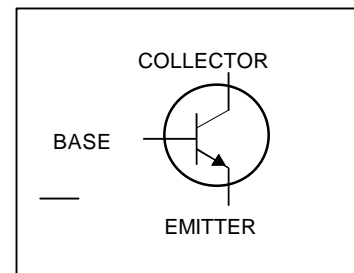
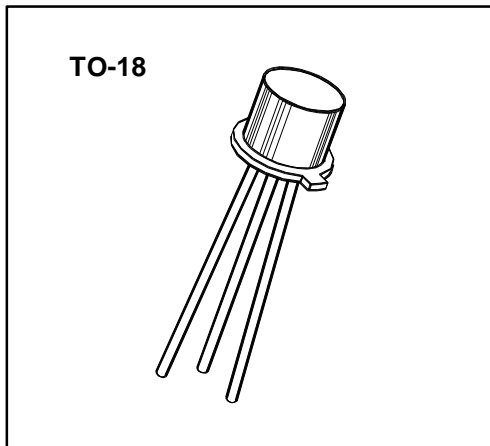

Maximum Ratings

RATING	SYMBOL	VALUE	UNIT
Collector - Emitter Voltage	V_{CEO}	50	Vdc
Collector - Base Voltage	V_{CBO}	75	Vdc
Emitter - Base Voltage	V_{EBO}	6	Vdc
Collector Current -- Continuous	I_C	800	mAdc
Total Device Dissipation @ $T_A = 25\text{ }^\circ\text{C}$	P_D	500	mW
Derate above 25 $^\circ\text{C}$		2.85	mW/ $^\circ\text{C}$
Total Device Dissipation @ $T_C = 25\text{ }^\circ\text{C}$	P_D	1.8	WATTS
Derate above 25 $^\circ\text{C}$		10.3	mW/ $^\circ\text{C}$
Operating Junction&Storage Temperature Range	T_J, T_{stg}	- 65 to + 200	$^\circ\text{C}$

Thermal Characteristics

CHARACTERISTIC	SYMBOL	MAX	UNIT
Thermal Resistance, Junction to Ambient	$R_{\theta JA}$	350	$^\circ\text{C}/\text{W}$

Electrical Characteristics ($T_A = 25^\circ\text{C}$ unless otherwise noted)

OFF CHARACTERISTIC	SYMBOL	MIN	MAX	UNIT
Collector - Emitter Breakdown Voltage (1) ($I_C = 10 \text{ mA dc}$, $I_B = 0$)	$V(BR)_{CEO}$	50		Vdc
Collector - Base Breakdown Voltage (1) ($I_C = 10 \text{ mA dc}$, $I_E = 0$)	$V(BR)_{CBO}$	75		Vdc
Emitter - Base Breakdown Voltage (1) ($I_E = 10 \text{ mA dc}$, $I_C = 0$)	$V(BR)_{EBO}$	6		Vdc
Collector - Emitter Cutoff Current ($V_{CE} = 50 \text{ Vdc}$, $V_{BE(off)} = 0 \text{ V}$)	I_{CES}		50	nAdc
Collector - Base Cutoff Current ($V_{CB} = 60 \text{ Vdc}$, $I_E = 0$)	I_{CBO}		10	nAdc
($V_{CB} = 60 \text{ Vdc}$, $I_E = 0$, $T_A = 150^\circ\text{C}$)			10	mAdc
Emitter - Base Cutoff Current ($V_{EB} = 4 \text{ Vdc}$)	I_{EBO}		10	nAdc

ON CHARACTERISTIC	SYMBOL	MIN	MAX	UNIT
DC Current Gain ($I_C = 100 \text{ mA dc}$, $V_{CE} = 10 \text{ Vdc}$)	h_{FE}	30		
($I_C = 1 \text{ mA dc}$, $V_{CE} = 10 \text{ Vdc}$)		35	150	
($I_C = 10 \text{ mA dc}$, $V_{CE} = 10 \text{ Vdc}$)		40		
($I_C = 150 \text{ mA dc}$, $V_{CE} = 10 \text{ Vdc}$) (1)		40	120	
($I_C = 500 \text{ mA dc}$, $V_{CE} = 10 \text{ Vdc}$) (1)		20		
($I_C = 10 \text{ mA dc}$, $V_{CE} = 10 \text{ Vdc}$, $T_J = -55^\circ\text{C}$)		15		
Collector - Emitter Saturation Voltage ($I_C = 150 \text{ mA dc}$, $I_B = 15 \text{ mA dc}$) (1)	$V_{CE(sat)}$		0.3	Vdc
($I_C = 500 \text{ mA dc}$, $I_B = 50 \text{ mA dc}$) (1)			1.0	Vdc
Base - Emitter Saturation Voltage ($I_C = 150 \text{ mA dc}$, $I_B = 15 \text{ mA dc}$) (1)	$V_{BE(sat)}$	0.6	1.2	Vdc
($I_C = 500 \text{ mA dc}$, $I_B = 50 \text{ mA dc}$) (1)			2.0	Vdc

1. Pulse Test: Pulse Width $\leq 300 \mu\text{s}$, Duty Cycle $\leq 2.0\%$

2N2221A

Electrical Characteristics (T_A = 25°C unless otherwise noted)

SMALL - SIGNAL CHARACTERISTICS	SYMBOL	MIN	MAX	UNIT
Output Capacitance (V _{CB} = 10 Vdc, I _E = 0, 100kHz &f &f 1 MHz)	C _{obo}		8	pF
Input Capacitance (V _{EB} = 0.5 Vdc, I _C = 0, 100kHz &f &f 1 MHz)	C _{ibo}		25	pF

SWITCHING CHARACTERISTICS	SYMBOL	MIN	MAX	UNIT
Turn - On Time (V _{CC} = 30 Vdc, I _C = 150 mAdc, I _{B1} = 15 mAdc) (See FIGURE 1)	t _{on}		35	ns
Turn - Off Time (V _{CC} = 30 Vdc, I _C = 150 mAdc, I _{B1} = - I _{B2} = 15 mAdc) (See FIGURE 2)	t _{off}		300	ns

Small - Signal AC Characteristics (T_A = 25°C)

LOW FREQUENCY	SYMBOL	MIN	MAX	UNIT
Common - Emitter Forward Current Transfer Ratio (I _C = 1 mA, V _{CE} = 10 V, f = 1kHz)	h _{fe}	30		
HIGH FREQUENCY				
Common - Emitter Forward Current Transfer Ratio (I _C = 20 mA, V _{CE} = 20 V, f = 100 MHz)	h _{fe}	2.5		

Spice Model (based upon typical device characteristics) *1

Q2N2221A NPN (IS = 426.3f XTI = 3.0 EG = 1.11 VAF = 250.3 BF = 72.14 ISE = 48.14p
 + NE = 2.935 IKF = 2.935 NK = 1.401 XTB = 1.5 BR = 11.49 ISC = 19.9f
 + NC = 1.88 IKR = 10.75 RC = 0.3567 CJC = 11.02p VJC = 0.3869 MJC = 0.3292
 + FC = 0.5 CJE = 29.31p VJE = 0.9036 MJE = 0.4101 TR = 16.89n TF = 537.5p
 + ITF = 0.1383 XTF = 84.83m VTF = 10)

*1. Microsemi Corp. claims no responsibility for misapplication of Spice Model information. Spice modeling should be used as a precursor guide to in-circuit performance. Actual performance is the responsibility of the user/designer.

2N2221A

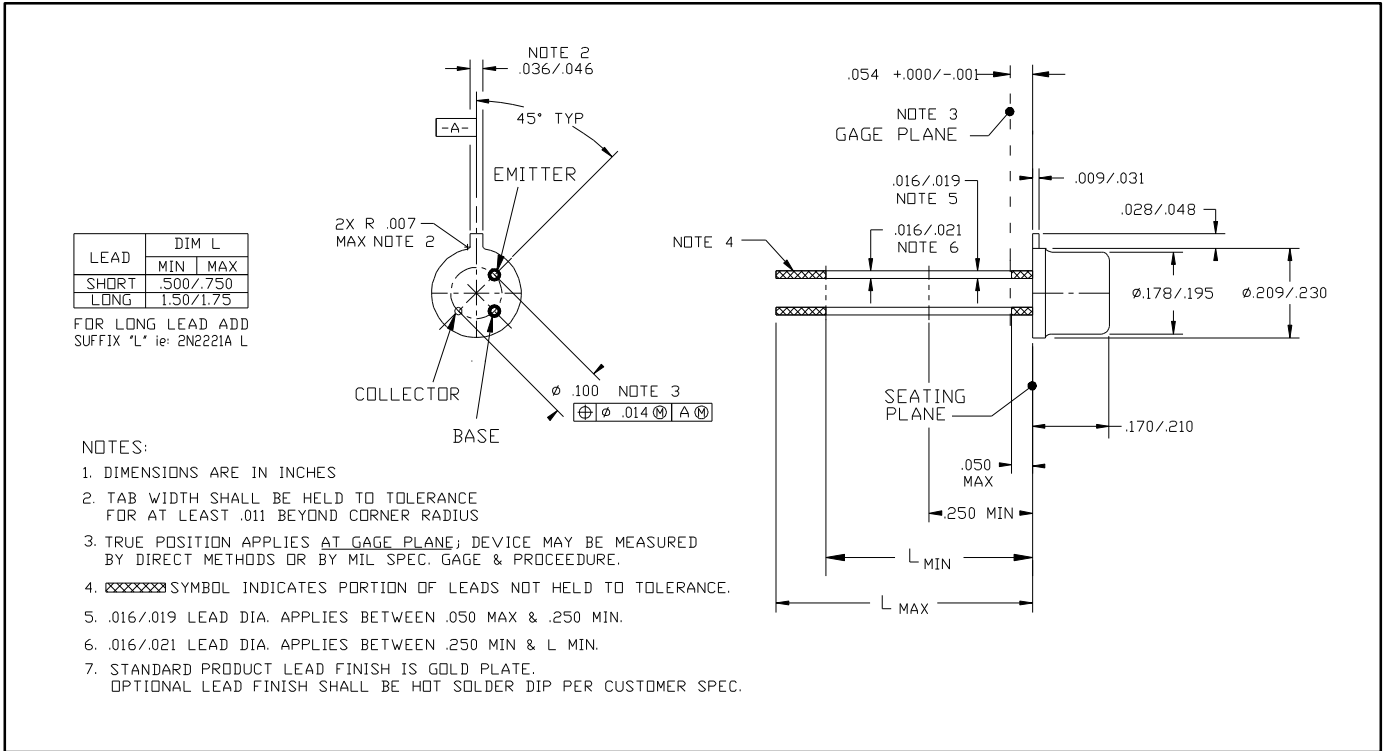

TO 18 CASE OUTLINE

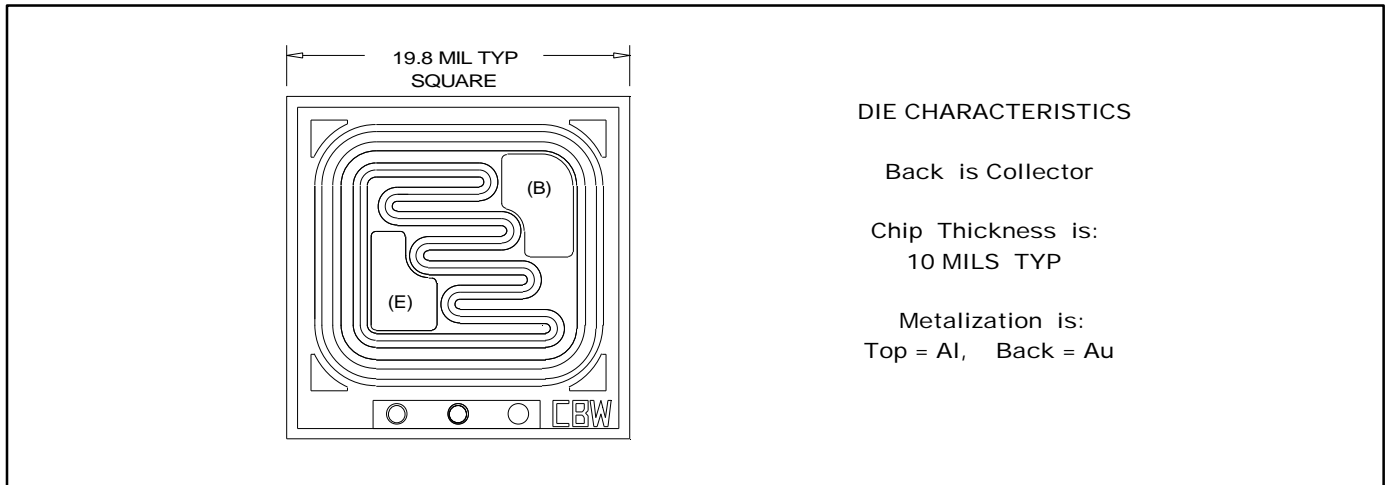

DIE OUTLINE

2N2221A

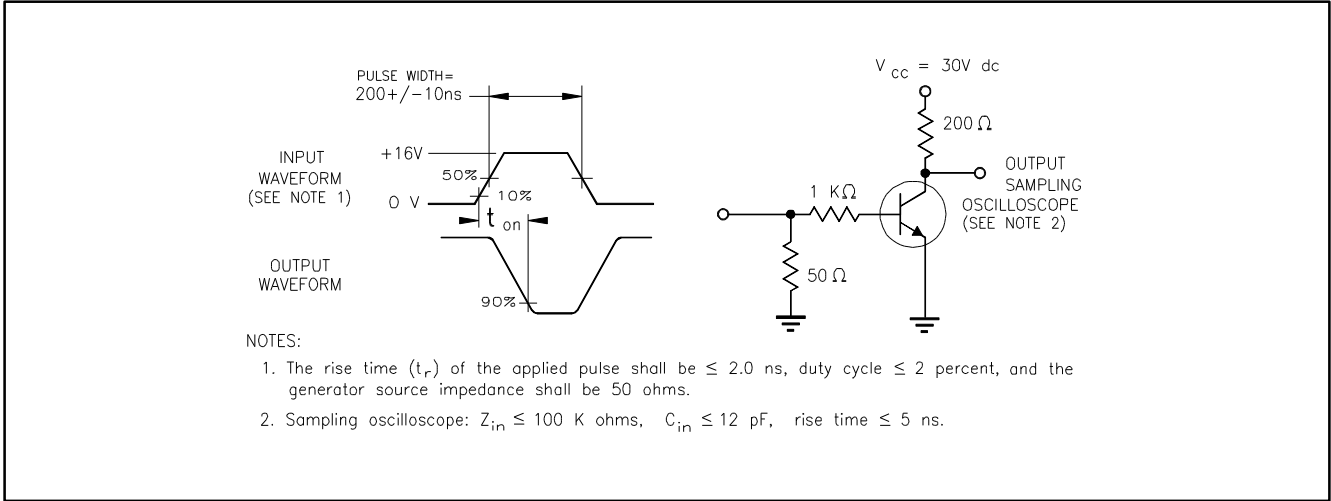

FIGURE 1 Saturated Turn-on Time Test Circuit

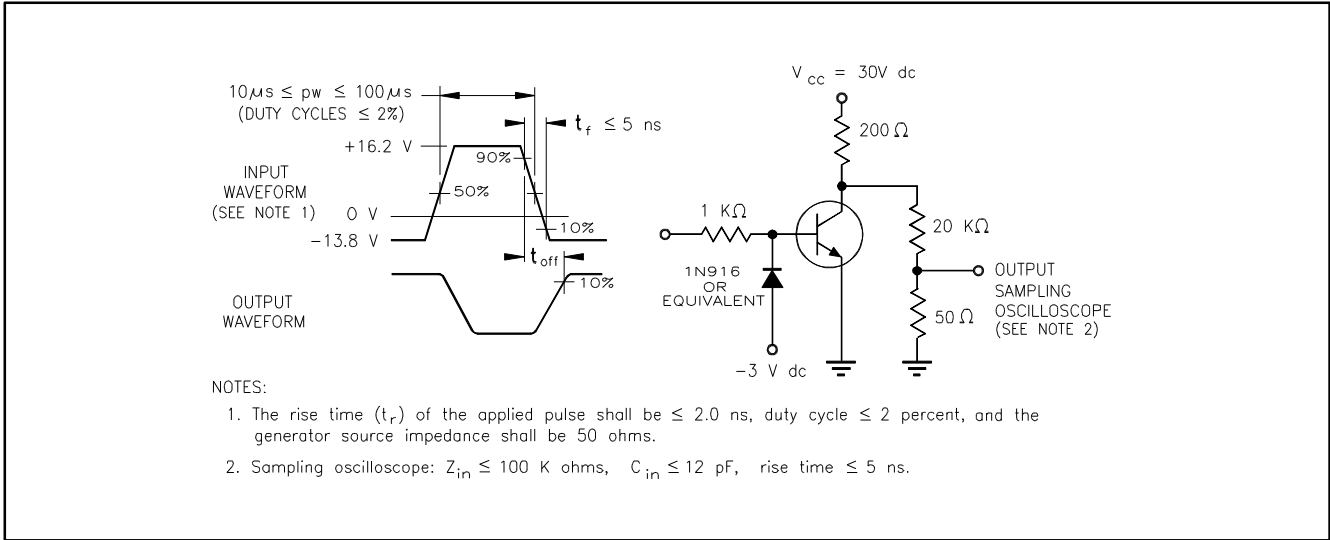

FIGURE 2 Saturated Turn-off Time Test Circuit

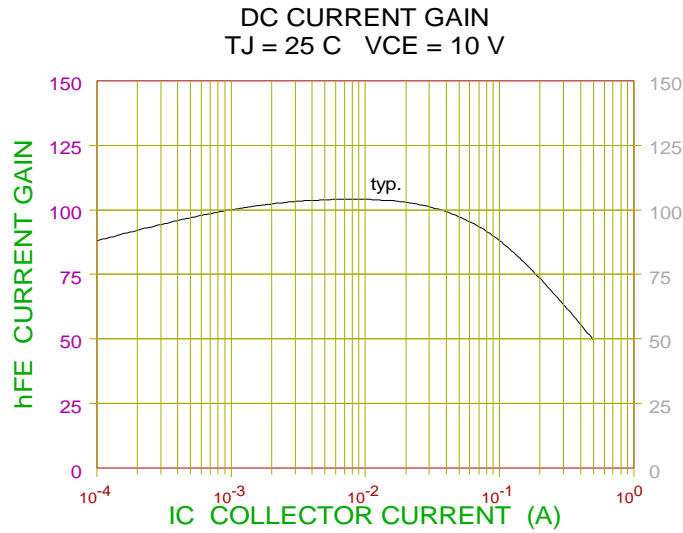

FIGURE 3

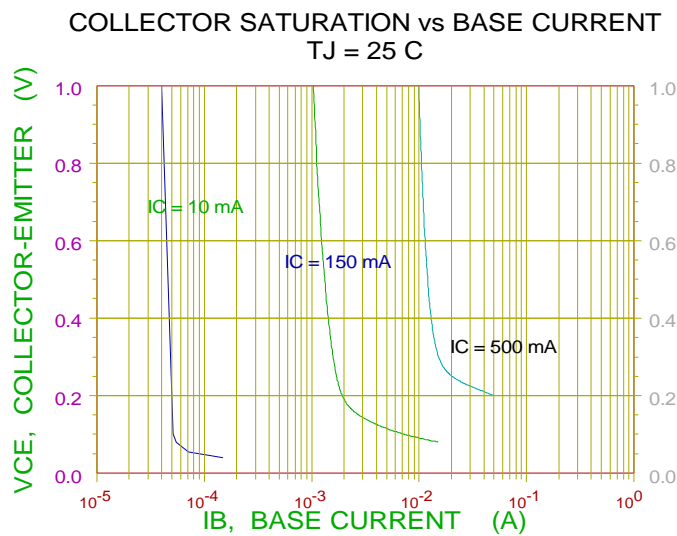

FIGURE 4

BASE SATURATION vs BASE CURRENT
 T_J = 25 C

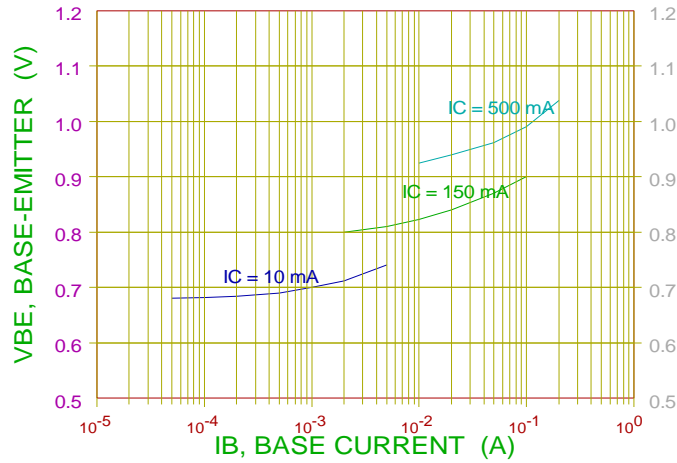

FIGURE 5

JUNCTION CAPACITANCE
 T_J = 25 C 100 kHz < f < 1 MHz

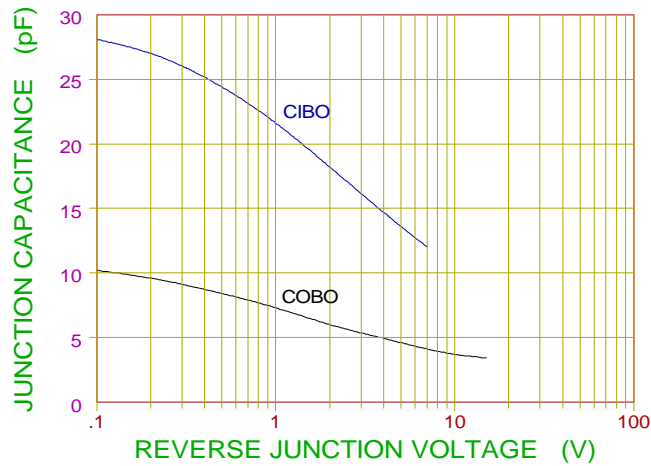

FIGURE 6

SMALL SIGNAL CURENT GAIN vs COLLECTOR CURRENT

TJ = 25 C VCE = 10 V f = 1kHz

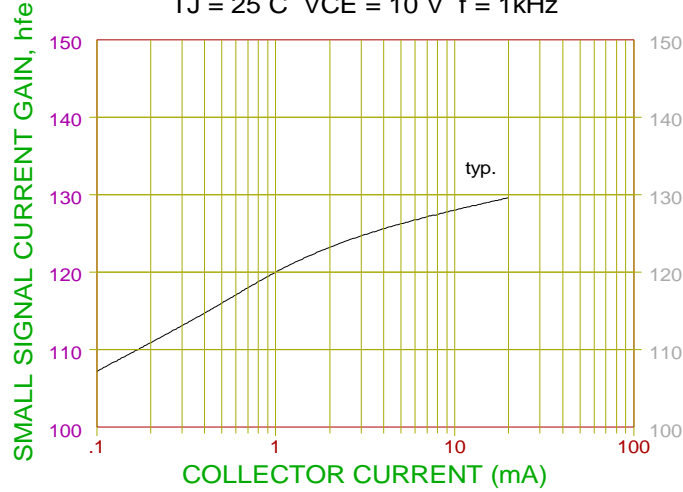

FIGURE 7

HIGH FREQUENCY GAIN
TJ = 25 C VCE = 20 V f = 100 MHz

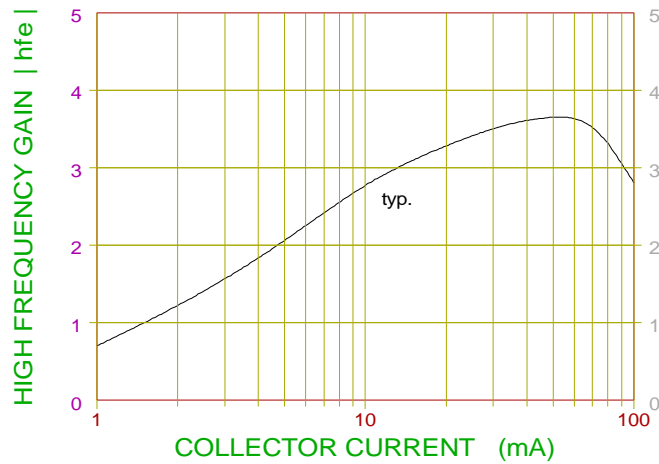

FIGURE 8

2N2221A

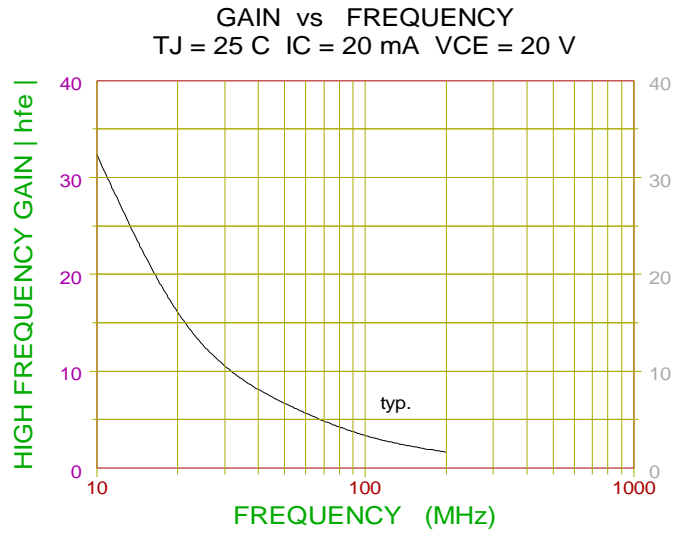

FIGURE 9



LittleDiode supplies new, hard to find or obsolete electronic components and semiconductors all over the world.

With over two million different components listed you are sure to find the part you need.

Feel free to visit us today at our online store:

LittleDiode.com

Looking forward to providing you with the best possible service.