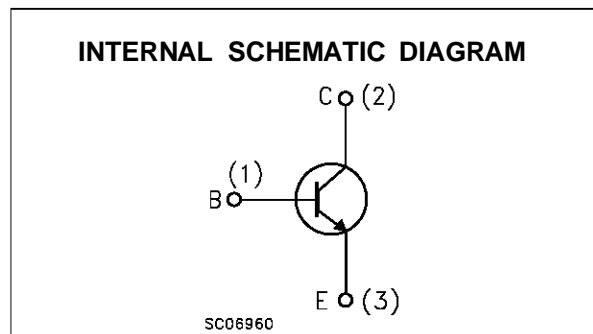
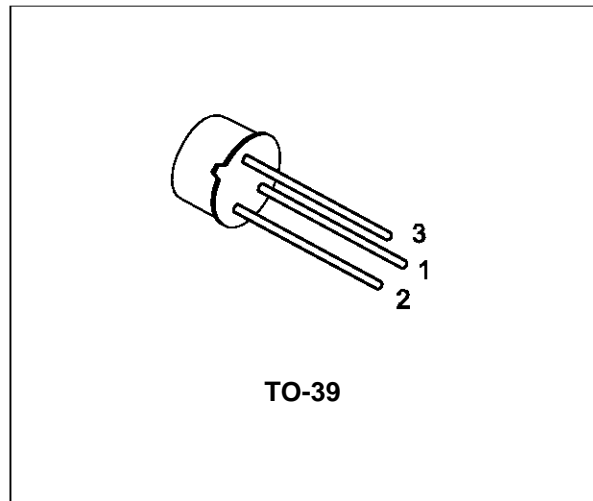

MEDIUM POWER AMPLIFIER
DESCRIPTION

The BFY50 and BFY52 are silicon planar epitaxial NPN transistors in Jedec TO-39 metal case. They are intended for general purpose linear and switching applications.

ABSOLUTE MAXIMUM RATINGS

Symbol	Parameter	Value		Unit
		BFY50	BFY51	
V_{CBO}	Collector-Base Voltage ($I_E = 0$)	80	60	V
V_{CEO}	Collector-Emitter Voltage ($I_B = 0$)	35	30	V
V_{EBO}	Emitter-Base Voltage ($I_C = 0$)	6		V
I_C	Collector Current	1		A
I_{CM}	Collector Peak Current ($t_p < 5$ ms)	1.5		A
P_{tot}	Total Dissipation at $T_{amb} \leq 25$ °C at $T_{case} \leq 25$ °C	0.8		W
		5		W
T_{stg}	Storage Temperature	-65 to 200		°C
T_j	Max. Operating Junction Temperature	200		°C

BFY50/BFY51

THERMAL DATA

$R_{thj-case}$	Thermal Resistance Junction-Case	Max	35	$^{\circ}C/W$
$R_{thj-amb}$	Thermal Resistance Junction-Ambient	Max	218	$^{\circ}C/W$

ELECTRICAL CHARACTERISTICS ($T_{case} = 25^{\circ}C$ unless otherwise specified)

Symbol	Parameter	Test Conditions	Min.	Typ.	Max.	Unit
I_{CBO}	Collector Cut-off Current ($I_E = 0$)	for BFY50 $V_{CB} = 60 V$ $V_{CB} = 60 V$ $T_{case} = 100^{\circ}C$ for BFY51 $V_{CB} = 40 V$ $V_{CB} = 40 V$ $T_{case} = 100^{\circ}C$			50 2.5 50 2.5	nA μA nA μA
I_{EBO}	Emitter Cut-off Current ($I_C = 0$)	$V_{EB} = 5 V$ $V_{EB} = 5 V$ $T_{case} = 100^{\circ}C$			50 2.5	nA μA
$V_{(BR)CBO}$	Collector-Base Breakdown Voltage ($I_E = 0$)	$I_C = 100 \mu A$ for BFY50 for BFY51	80 60			V V
$V_{(BR)CEO}^*$	Collector-Emitter Breakdown Voltage ($I_B = 0$)	$I_C = 30 mA$ for BFY50 for BFY51	35 30			V V
$V_{(BR)EBO}$	Emitter-Base Breakdown Voltage ($I_C = 0$)	$I_C = 100 \mu A$	6			V
$V_{CE(sat)}^*$	Collector-Emitter Saturation Voltage	$I_C = 150 mA$ $I_B = 15 mA$ for BFY50 for BFY51 $I_C = 1 A$ $I_B = 0.1 A$ for BFY50 for BFY51		0.14 0.14 0.7 0.7	0.2 0.35 1 1.6	V V V V
$V_{BE(sat)}^*$	Base-Emitter Saturation Voltage	$I_C = 150 mA$ $I_B = 15 mA$ $I_C = 1 A$ $I_B = 0.1 A$		0.95 1.5	1.3 2	V V
h_{FE}^*	DC Current Gain	for BFY50 $I_C = 10 mA$ $V_{CE} = 10 V$ $I_C = 150 mA$ $V_{CE} = 10 V$ $I_C = 1 A$ $V_{CE} = 10 V$ for BFY51 $I_C = 10 mA$ $V_{CE} = 10 V$ $I_C = 150 mA$ $V_{CE} = 10 V$ $I_C = 1 A$ $V_{CE} = 10 V$	20 30 15 30 40 15	40 55 30 55 70 40		
h_{fe}^*	Small Signal Current Gain	$V_{CE} = 6 V$ $f = 1 KHz$ $I_C = 1 mA$ for BFY50 for BFY51 $I_C = 10 mA$ for BFY50 for BFY51		25 30 45 60		
f_T	Transition Frequency	$I_C = 50 mA$ $V_{CE} = 10 V$ for BFY50 for BFY51	60 50	100 110		MHz MHz
C_{CBO}	Collector Base Capacitance	$I_E = 0$ $V_{CB} = 10 V$ $f = 1 MHz$		10		pF

* Pulsed: Pulse duration = 300 μs , duty cycle $\leq 1\%$

ELECTRICAL CHARACTERISTICS (continued)

Symbol	Parameter	Test Conditions	Min.	Typ.	Max.	Unit
h_{ie}	Input Impedance	$I_C = 10 \text{ mA}$ $V_{CE} = 5 \text{ V}$ $f = 1 \text{ KHz}$ for BFY50 for BFY51		180 220		Ω Ω
h_{re}	Reverse Voltage Ratio	$I_C = 10 \text{ mA}$ $V_{CE} = 5 \text{ V}$ $f = 1 \text{ KHz}$ for BFY50 for BFY51		55 70		10^{-6} 10^{-6}
h_{oe}	Output Admittance	$I_C = 10 \text{ mA}$ $V_{CE} = 5 \text{ V}$ $f = 1 \text{ KHz}$ for BFY50 for BFY51		30 35		μS μS
t_d	Delay Time	$I_C = 150 \text{ mA}$ $V_{CC} = 10 \text{ V}$ $I_{B1} = 15 \text{ mA}$ $V_{BE} = -2 \text{ V}$		15		ns
t_r	Rise Time	$I_C = 150 \text{ mA}$ $V_{CC} = 10 \text{ V}$ $I_{B1} = 15 \text{ mA}$ $V_{BE} = -2 \text{ V}$		40		ns
t_s	Storage Time	$I_C = 150 \text{ mA}$ $V_{CC} = 10 \text{ V}$ $I_{B1} = -I_{B2} = 15 \text{ mA}$		300		ns
t_f	Fall Time	$I_C = 150 \text{ mA}$ $V_{CC} = 10 \text{ V}$ $I_{B1} = -I_{B2} = 15 \text{ mA}$		60		ns

* Pulsed: Pulse duration = 300 μs , duty cycle $\leq 1\%$

TO-39 MECHANICAL DATA

DIM.	mm			inch		
	MIN.	TYP.	MAX.	MIN.	TYP.	MAX.
A	12.7			0.500		
B			0.49			0.019
D			6.6			0.260
E			8.5			0.334
F			9.4			0.370
G	5.08			0.200		
H			1.2			0.047
I			0.9			0.035
L	45° (typ.)					

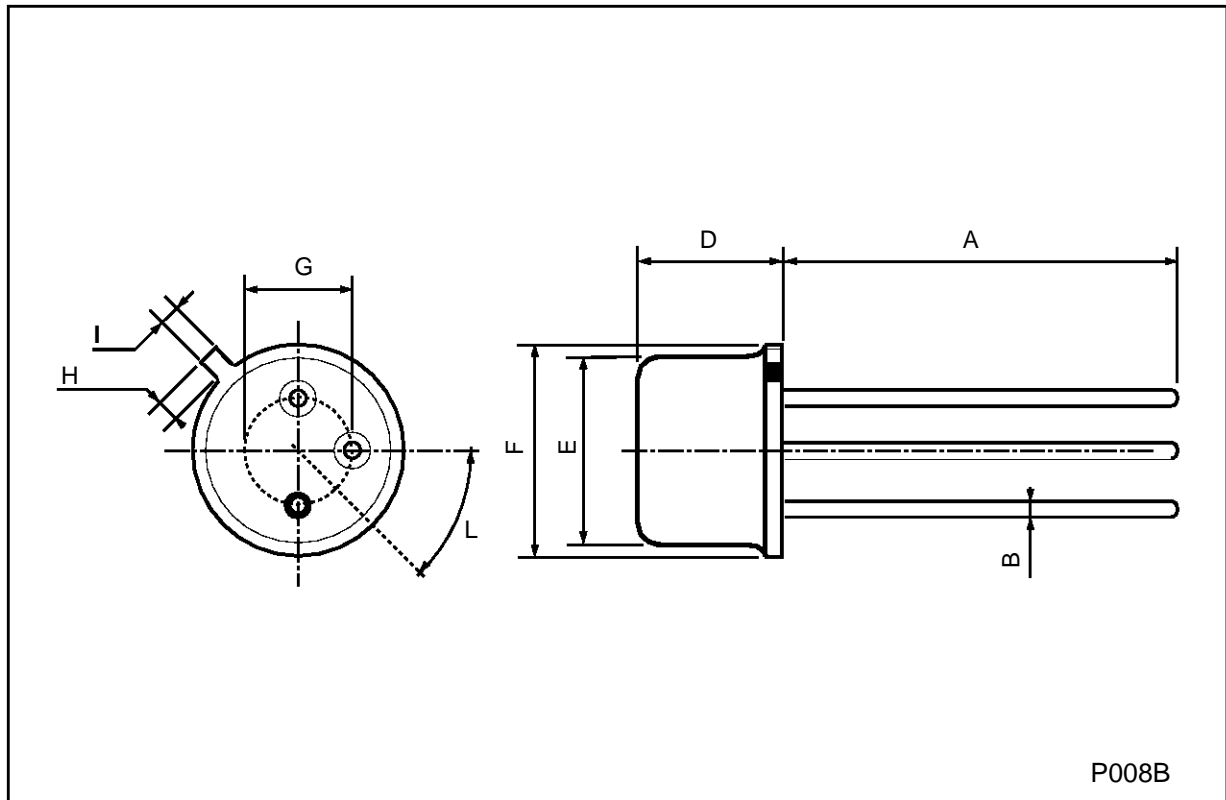

P008B

Information furnished is believed to be accurate and reliable. However, SGS-THOMSON Microelectronics assumes no responsibility for the consequences of use of such information nor for any infringement of patents or other rights of third parties which may result from its use. No license is granted by implication or otherwise under any patent or patent rights of SGS-THOMSON Microelectronics. Specifications mentioned in this publication are subject to change without notice. This publication supersedes and replaces all information previously supplied. SGS-THOMSON Microelectronics products are not authorized for use as critical components in life support devices or systems without express written approval of SGS-THOMSON Microelectronics.

© 1997 SGS-THOMSON Microelectronics - Printed in Italy - All Rights Reserved

SGS-THOMSON Microelectronics GROUP OF COMPANIES

Australia - Brazil - Canada - China - France - Germany - Italy - Japan - Korea - Malaysia - Malta - Morocco - The Netherlands -
Singapore - Spain - Sweden - Switzerland - Taiwan - Thailand - United Kingdom - U.S.A

...

This datasheet has been downloaded from:

www.DatasheetCatalog.com

Datasheets for electronic components.



LittleDiode supplies new, hard to find or obsolete electronic components and semiconductors all over the world.

With over two million different components listed you are sure to find the part you need.

Feel free to visit us today at our online store:

LittleDiode.com

Looking forward to providing you with the best possible service.