

REPETITIVE AVALANCHE AND dv/dt RATED\*

HEXFET® TRANSISTORS

IRF720

IRF721

IRF722

IRF723

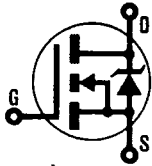

N-CHANNEL

400 Volt, 1.8 Ohm HEXFET TO-220AB Plastic Package

The HEXFET® technology is the key to International Rectifier's advanced line of power MOSFET transistors. The efficient geometry and unique processing of this latest "State of the Art" design achieves: very low on-state resistance combined with high transconductance; superior reverse energy and diode recovery dv/dt capability.

The HEXFET transistors also feature all of the well established advantages of MOSFETs such as voltage control, very fast switching, ease of paralleling and temperature stability of the electrical parameters.

They are well suited for applications such as switching power supplies, motor controls, inverters, choppers, audio amplifiers and high energy pulse circuits.

Product Summary

| Part Number | BVDSS | R <sub>DS(on)</sub> | I <sub>D</sub> |
|-------------|-------|---------------------|----------------|
| IRF720      | 400V  | 1.8Ω                | 3.3A           |
| IRF721      | 350V  | 1.8Ω                | 3.3A           |
| IRF722      | 400V  | 2.5Ω                | 2.8A           |
| IRF723      | 350V  | 2.5Ω                | 2.8A           |

FEATURES:

- Repetitive Avalanche Ratings
- Dynamic dv/dt Rating
- Simple Drive Requirements
- Ease of Paralleling

CASE STYLE AND DIMENSIONS

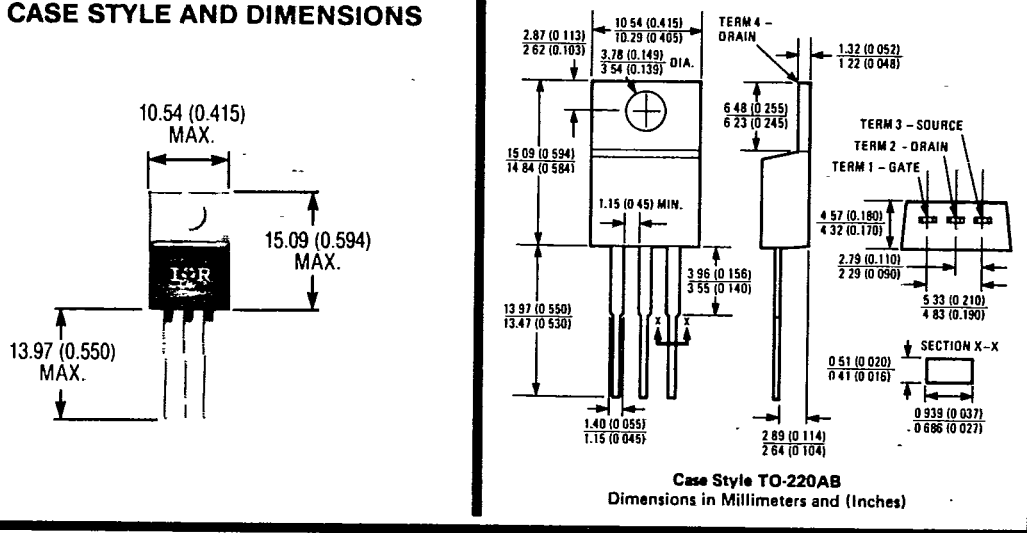

\*This data sheet applies to product with batch codes that begin with a digit, ie. 2A3B  
C-277

Absolute Maximum Ratings

| Parameter   | IRF720, IRF721                            | IRF722, IRF723 | Units                        |
|---|---|----------------|------------------------------|
| $I_D @ T_C = 25^\circ\text{C}$ Continuous Drain Current                               | 3.3                                       | 2.8            | A                            |
| $I_D @ T_C = 100^\circ\text{C}$ Continuous Drain Current                              | 2.1                                       | 1.8            | A                            |
| $I_{DM}$ Pulsed Drain Current $\text{\textcircled{1}}$                                | 13  | 11             | A                            |
| $P_D @ T_C = 25^\circ\text{C}$ Max. Power Dissipation                                 | 50  |                | W                            |
| Linear Derating Factor  | 0.40                                      |                | W/K $\text{\textcircled{2}}$ |
| $V_{GS}$ Gate-to-Source Voltage   | $\pm 20$                                  |                | V                            |
| $E_{AS}$ Single Pulse Avalanche Energy $\text{\textcircled{2}}$                       | 190<br>(See Fig. 14)                      |                | mJ                           |
| $I_{AR}$ Avalanche Current $\text{\textcircled{1}}$<br>(Repetitive or Non-Repetitive) | 3.3<br>(See $E_{AR}$ )                    |                | A                            |
| $E_{AR}$ Repetitive Avalanche Energy $\text{\textcircled{1}}$                         | 5.0<br>(See $I_{AR}$ )                    |                | mJ                           |
| $dv/dt$ Peak Diode Recovery $dv/dt$ $\text{\textcircled{3}}$                          | 4.0<br>(See Fig. 17)                      |                | V/ns                         |
| $T_J$ Operating Junction<br>$T_{STG}$ Storage Temperature Range                       | -55 to 150                                |                | $^\circ\text{C}$             |
| Lead Temperature  | 300 (0.063 in. (1.6mm) from case for 10s) |                | $^\circ\text{C}$             |

Electrical Characteristics @  $T_J = 25^\circ\text{C}$  (Unless Otherwise Specified)

| Parameter  | Type             | Min. | Typ. | Max. | Units         | Test Conditions  |
|--|------------------|------|------|------|---------------|--|
| $BV_{DSS}$ Drain-to-Source Breakdown Voltage                                     | IRF720<br>IRF722 | 400  | —    | —    | V             | $V_{GS} = 0V, I_D = 250 \mu\text{A}$   |
|  | IRF721<br>IRF723 | 350  | —    | —    |               |  |
| $R_{DS(on)}$ Static Drain-to-Source On-State Resistance $\text{\textcircled{4}}$ | IRF720<br>IRF721 | —    | 1.6  | 1.8  | $\Omega$      | $V_{GS} = 10V, I_D = 1.8A$   |
|  | IRF722<br>IRF723 | —    | 1.8  | 2.5  |               |  |
| $I_{D(on)}$ On-State Drain Current $\text{\textcircled{4}}$                      | IRF720<br>IRF721 | 3.3  | —    | —    | A             | $V_{DS} > I_{D(on)} \times R_{DS(on)}$ Max.<br>$V_{GS} = 10V$  |
|  | IRF722<br>IRF723 | 2.8  | —    | —    |               |  |
| $V_{GS(th)}$ Gate Threshold Voltage  | ALL              | 2.0  | —    | 4.0  | V             | $V_{DS} = V_{GS}, I_D = 250 \mu\text{A}$   |
| $g_{fs}$ Forward Transconductance $\text{\textcircled{4}}$                       | ALL              | 1.8  | 2.7  | —    | S (f)         | $I_{DS} = 1.8A, V_{DS} \geq 50V$   |
| $I_{DSS}$ Zero Gate Voltage Drain Current  | ALL              | —    | —    | 250  | $\mu\text{A}$ | $V_{DS} = \text{Max. Rating}, V_{GS} = 0V$<br>$V_{DS} = 0.8 \times \text{Max. Rating}$<br>$V_{GS} = 0V, T_J = 125^\circ\text{C}$   |
|  |                  | —    | —    | 1000 |               |  |
| $I_{GSS}$ Gate-to-Source Leakage Forward   | ALL              | —    | —    | 500  | nA            | $V_{GS} = 20V$   |
| $I_{GSS}$ Gate-to-Source Leakage Reverse   | ALL              | —    | —    | -500 | nA            | $V_{GS} = -20V$  |
| $Q_g$ Total Gate Charge  | ALL              | —    | 13   | 20   | nC            | $V_{GS} = 10V, I_D = 3.3A$<br>$V_{DS} = 0.8 \times \text{Max. Rating}$<br>See Fig. 16<br>(Independent of operating temperature)  |
| $Q_{gs}$ Gate-to-Source Charge   | ALL              | —    | 2.2  | 3.3  | nC            |  |
| $Q_{gd}$ Gate-to-Drain ("Miller") Charge   | ALL              | —    | 7.2  | 11   | nC            |  |
| $t_{d(on)}$ Turn-On Delay Time   | ALL              | —    | 10   | 15   | ns            | $V_{DD} = 200V, I_D \approx 3.3A, R_G = 18\Omega$<br>$R_D = 56\Omega$<br>See Fig. 15<br>(Independent of operating temperature)   |
| $t_r$ Rise Time  | ALL              | —    | 14   | 21   | ns            |  |
| $t_{d(off)}$ Turn-Off Delay Time   | ALL              | —    | 30   | 45   | ns            |  |
| $t_f$ Fall Time  | ALL              | —    | 13   | 20   | ns            |  |
| $L_D$ Internal Drain Inductance  | ALL              | —    | 4.5  | —    | nH            | Measured from the drain lead, 6mm (0.25 in.) from package to center of die.<br>Modified MOSFET symbol showing the internal inductances.<br> |
| $L_S$ Internal Source Inductance   | ALL              | —    | 7.5  | —    | nH            |  |
| $C_{iss}$ Input Capacitance  | ALL              | —    | 350  | —    | pF            | $V_{GS} = 0V, V_{DS} = 25V$  |
| $C_{oss}$ Output Capacitance   | ALL              | —    | 64   | —    | pF            | $f = 1.0 \text{ MHz}$  |
| $C_{rss}$ Reverse Transfer Capacitance   | ALL              | —    | 8.1  | —    | pF            | See Fig. 10  |

Source-Drain Diode Ratings and Characteristics

| Parameter                                     | Type | Min.   | Typ. | Max. | Units         | Test Conditions   |
|---|------|--|------|------|---------------|---|
| $I_S$ Continuous Source Current (Body Diode)  | ALL  | —  | —    | 3.3  | A             | Modified MOSFET symbol showing the integral Reverse p-n junction rectifier.  |
| $I_{SM}$ Pulsed Source Current (Body Diode) ① | ALL  | —  | —    | 13   | A             |   |
| $V_{SD}$ Diode Forward Voltage ②              | ALL  | —  | —    | 1.6  | V             | $T_J = 25^\circ\text{C}$ , $I_S = 3.3\text{A}$ , $V_{GS} = 0\text{V}$   |
| $t_{rr}$ Reverse Recovery Time                | ALL  | 120  | 270  | 600  | ns            | $T_J = 25^\circ\text{C}$ , $I_F = 3.3\text{A}$ , $di/dt = 100\text{ A}/\mu\text{s}$   |
| $Q_{RR}$ Reverse Recovery Charge              | ALL  | 0.64   | 1.4  | 3.0  | $\mu\text{C}$ |   |
| $t_{on}$ Forward Turn-On Time                 | ALL  | Intrinsic turn-on time is negligible. Turn-on speed is substantially controlled by $L_S + L_D$ . |      |      |               |   |

Thermal Resistance

|                                |     |   |      |     |      |  |
|--------------------------------|-----|---|------|-----|------|--|
| $R_{thJC}$ Junction-to-Case    | ALL | — | —    | 2.5 | KW ③ |  |
| $R_{thCS}$ Case-to-Sink        | ALL | — | 0.50 | —   | KW ③ | Mounting surface flat, smooth, and greased |
| $R_{thJA}$ Junction-to-Ambient | ALL | — | —    | 80  | KW ③ | Typical socket mount                       |

Typical SPICE Computer Model Parameters (For More Information See Application Note AN-975)

| Device | Level, SPICE MOSFET Model | W ( $\mu\text{m}$ ), Channel Width | L ( $\mu\text{m}$ ), Channel Length | Theta (1/V), Mobility Modulation | UO ( $\text{CM}^2/\text{V}\cdot\text{S}$ ), Surface Mobility | VTO (V), Threshold Voltage | R1 ( $\Omega$ ), Drain Resistance | R2 ( $\Omega$ ), Source Resistance | RG ( $\Omega$ ), Gate Resistance |
|--------|---------------------------|------------------------------------|-------------------------------------|----------------------------------|--|----------------------------|-----------------------------------|------------------------------------|----------------------------------|
| ALL    | 3                         | 0.279                              | 1.2                                 | 0.30                             | 450  | 4.00                       | 1.4                               | 0.02                               | 1.5                              |

| CGSO (pf), Gate-Source Capacitance | CGD (F), Gate-Drain Capacitance | E1 (V), Voltage Dependent Voltage Source | LD (nH), Drain Inductance | LS (nH), Source Inductance | LG (nH), Gate Inductance | IS (A), Diode Saturation Current | RS ( $\Omega$ ), Diode Bulk Resistance |
|------------------------------------|---------------------------------|--|---------------------------|----------------------------|--------------------------|----------------------------------|--|
| 770                                | C8                              | $2 + 0.995\text{VDG}$                    | 4.5                       | 7.5                        | 7.5                      | $3.8 \times 10^{-13}$            | 0.026                                  |

$C8 = 1500\text{ pf} + 1.8 \times 10^{-22} (V_{GE})^{48}$

① Repetitive Rating: Pulse width limited by maximum junction temperature (see figure 5) Refer to current HEXFET reliability report

②  $I_{SD} \leq 3.3\text{A}$ ,  $di/dt \leq 65\text{A}/\mu\text{s}$ ,  $V_{DD} \leq BV_{DSS}$ ,  $T_J \leq 150^\circ\text{C}$   
Suggested  $R_G = 18\Omega$

③  $\text{KW} = \text{°CW}$   
 $\text{W/K} = \text{W/°C}$

④ @  $V_{DD} = 50\text{V}$ , Starting  $T_J = 25^\circ\text{C}$ ,  $L = 31\text{ nH}$ ,  $R_G = 25\Omega$ , Peak  $I_L = 3.3\text{A}$ .

⑤ Pulse width  $\leq 300\ \mu\text{s}$ ; Duty Cycle  $\leq 2\%$

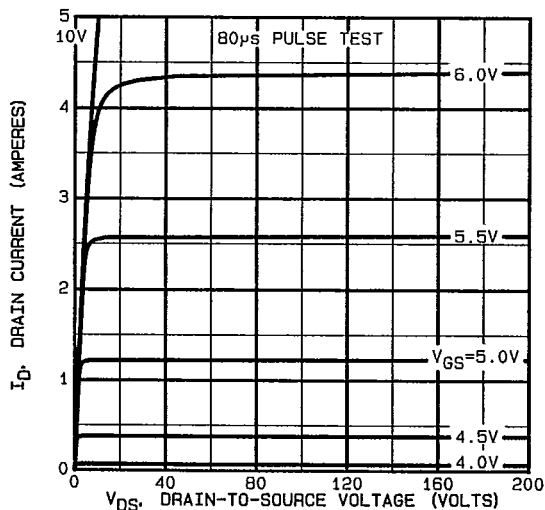

Fig. 1 — Typical Output Characteristics

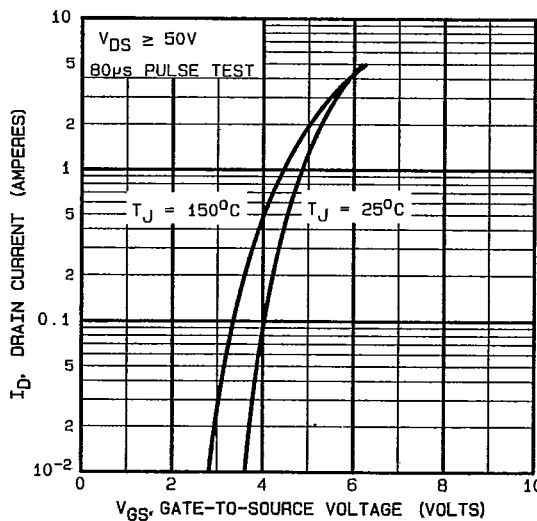

Fig. 2.— Typical Transfer Characteristics

INTERNATIONAL RECTIFIER

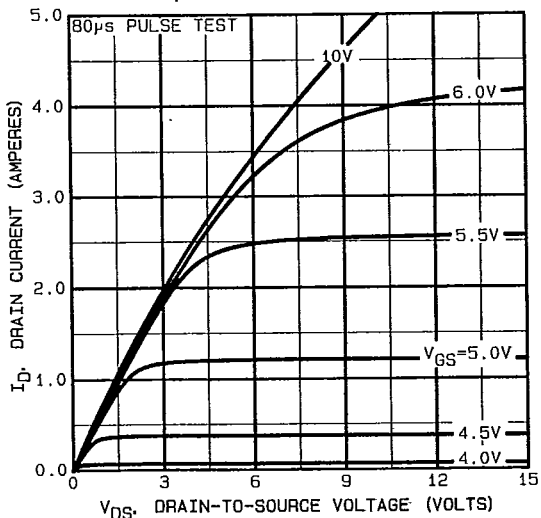

Fig. 3 — Typical Saturation Characteristics

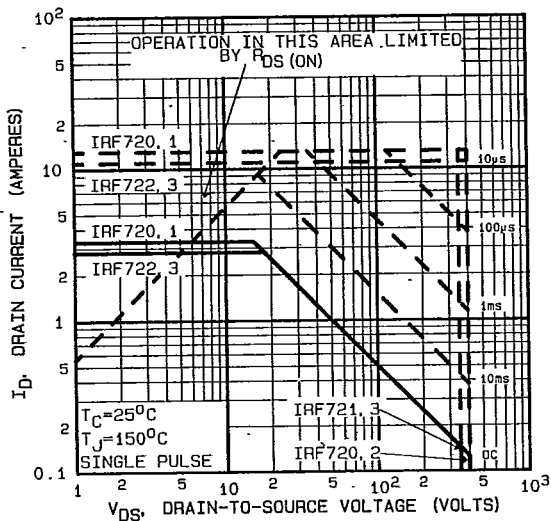

Fig. 4 — Maximum Safe Operating Area

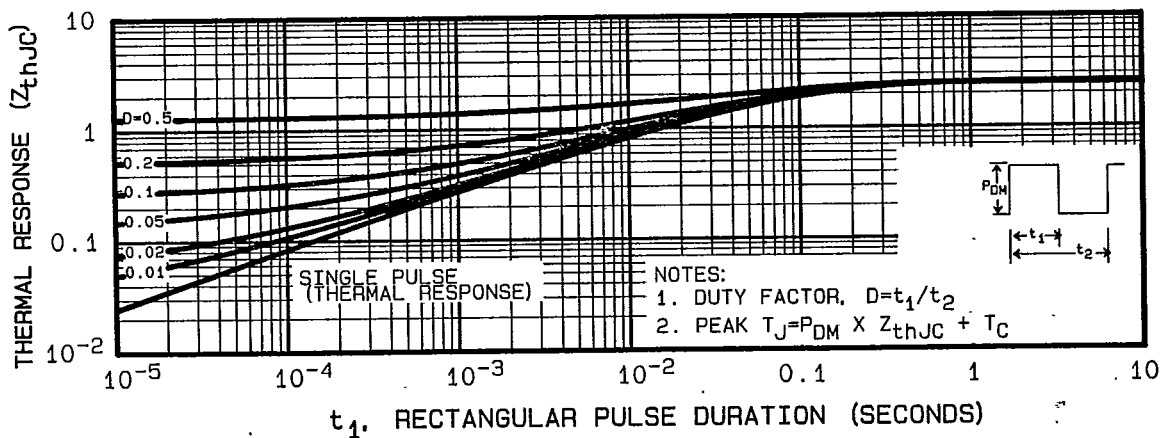

Fig. 5 — Maximum Effective Transient Thermal Impedance, Junction-to-Case Vs. Pulse Duration

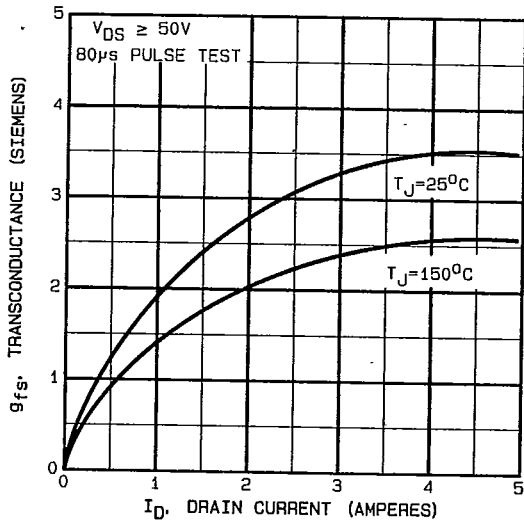

Fig. 6 — Typical Transconductance Vs. Drain Current

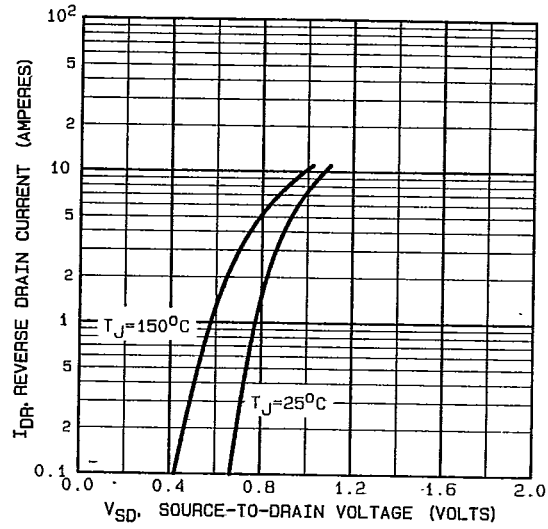

Fig. 7 — Typical Source-Drain Diode Forward Voltage

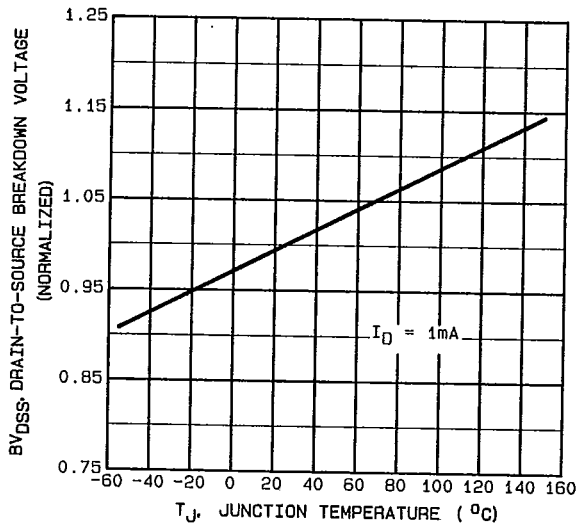

Fig. 8 — Breakdown Voltage Vs. Temperature

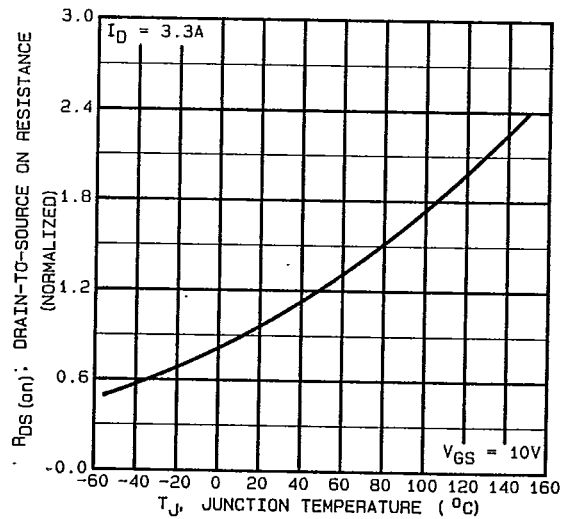

Fig. 9 — Normalized On-Resistance Vs. Temperature

IRF720, IRF721, IRF722, IRF723 Devices

INTERNATIONAL RECTIFIER

T-39-11

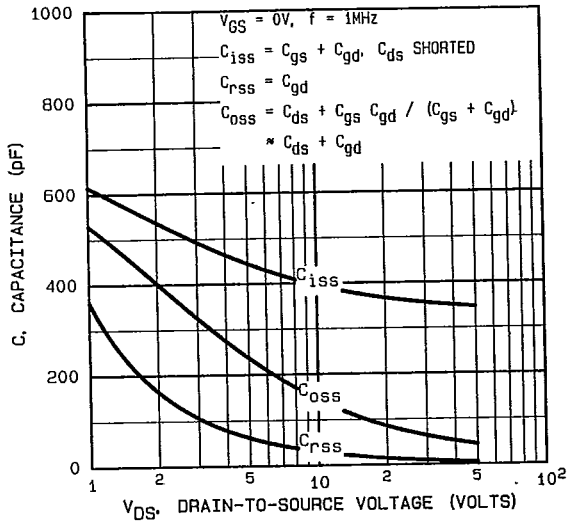

Fig. 10 — Typical Capacitance Vs. Drain-to-Source Voltage

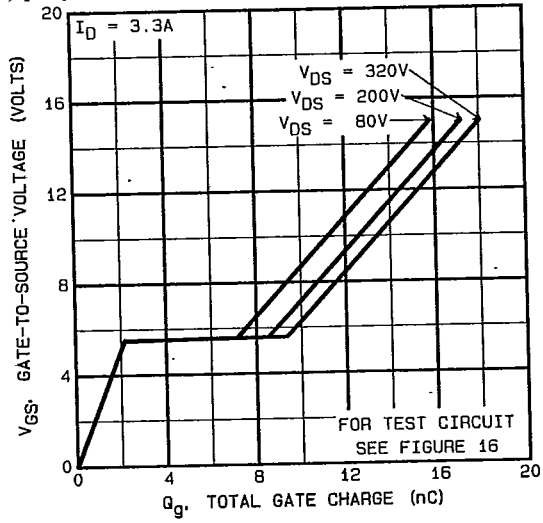

Fig. 11 — Typical Gate Charge Vs. Gate-to-Source Voltage

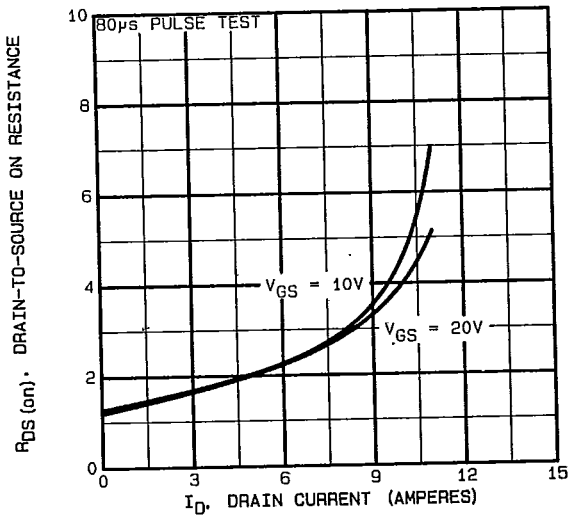

Fig. 12 — Typical On-Resistance Vs. Drain Current

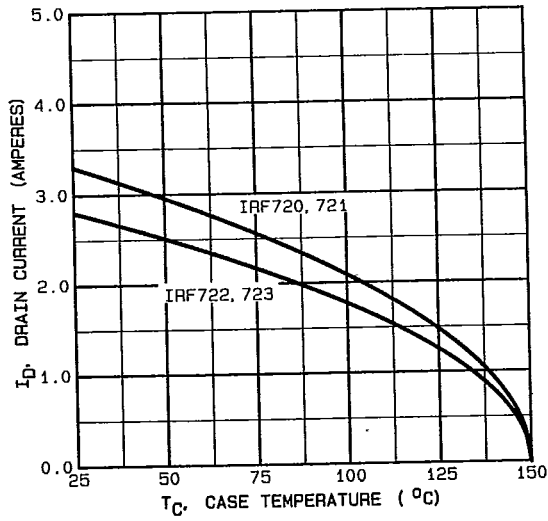

Fig. 13 — Maximum Drain Current Vs. Case Temperature

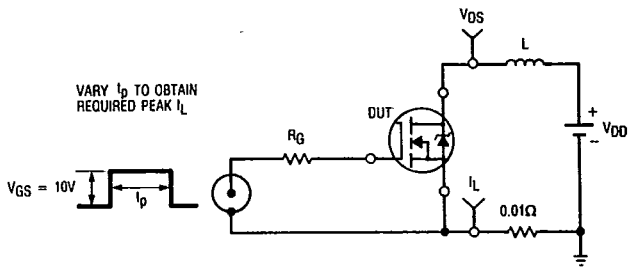

Fig. 14a — Unclamped Inductive Test Circuit

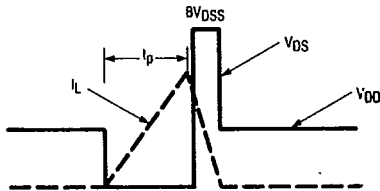

Fig. 14b — Unclamped Inductive Waveforms

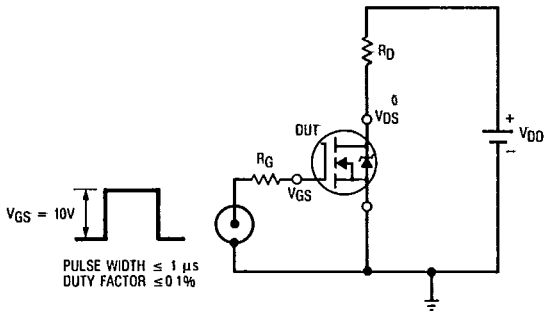

Fig. 15a — Switching Time Test Circuit

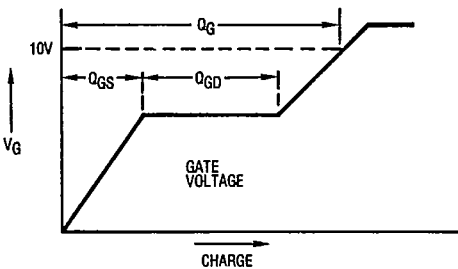

Fig. 16a — Basic Gate Charge Waveform

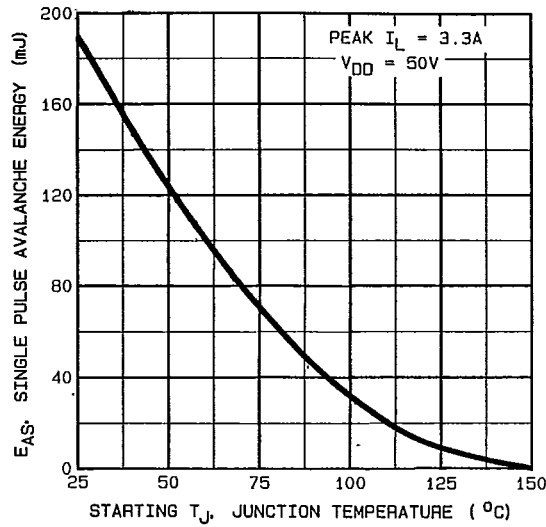

Fig. 14c — Maximum Avalanche Energy Vs. Starting Junction Temperature

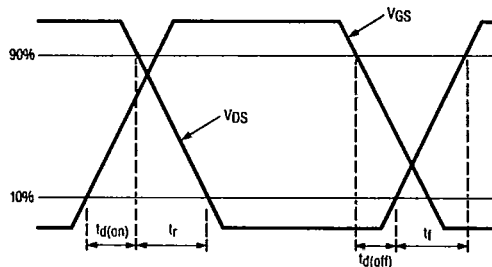

Fig. 15b — Switching Time Waveforms

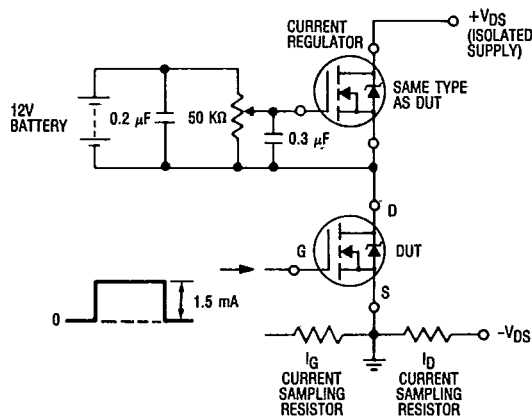

Fig. 16b — Gate Charge Test Circuit

IRF720, IRF721, IRF722, IRF723 Devices

INTERNATIONAL RECTIFIER

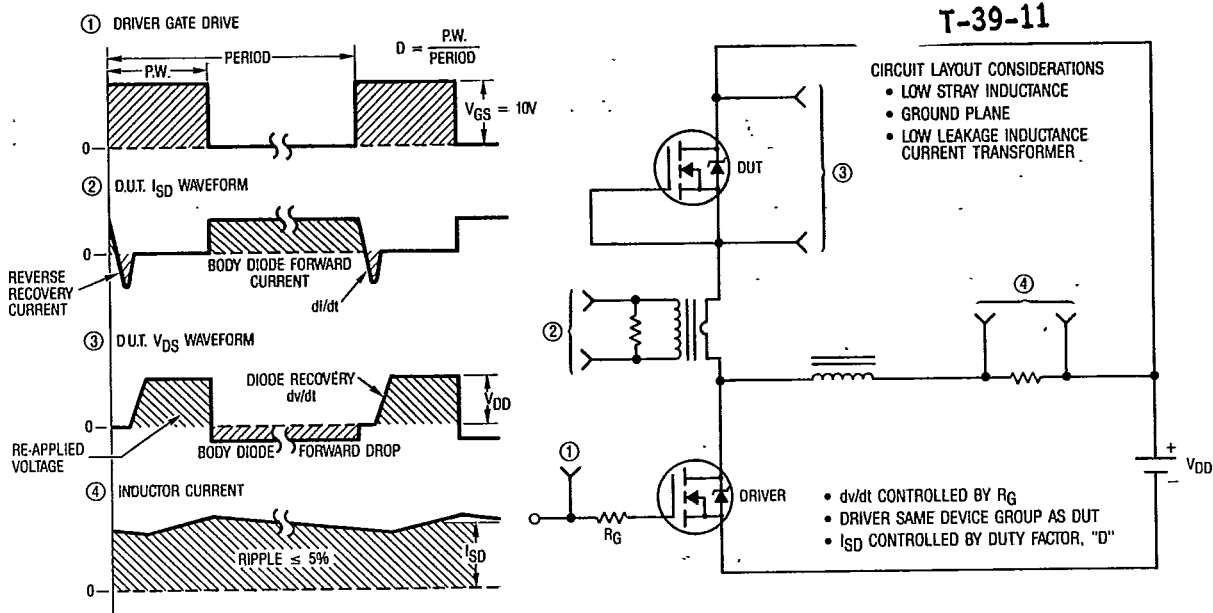
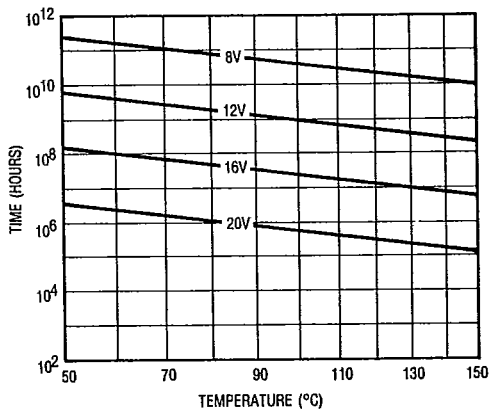
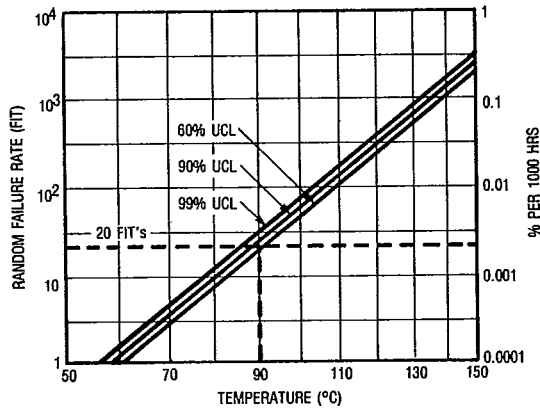

Fig. 17 — Peak Diode Recovery  $dv/dt$  Test Circuit



\*Fig. 18 — Typical Time to Accumulated 1% Gate Failure



\*Fig. 19 — Typical High Temperature Reverse Bias (HTRB) Failure Rate

\*The data shown is correct as of April 15, 1987. This information is updated on a quarterly basis; for the latest reliability data, please contact your local IR field office.

This datasheet has been downloaded from:

[www.DatasheetCatalog.com](http://www.DatasheetCatalog.com)

Datasheets for electronic components.



LittleDiode supplies new, hard to find or obsolete electronic components and semiconductors all over the world.

With over two million different components listed you are sure to find the part you need.

Feel free to visit us today at our online store:

**[LittleDiode.com](http://LittleDiode.com)**

Looking forward to providing you with the best possible service.