

**Glass Passivated Junction Plastic Rectifiers****Reverse Voltage**

200 to 1300V

Forward Current 3.0A

DO-201AD

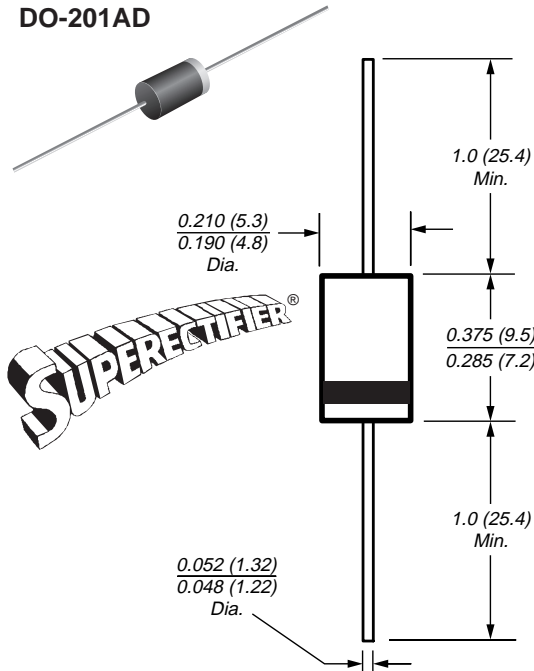

Dimensions in inches and (millimeters)

*Glass-plastic encapsulation technique is covered by

Patent No. 3,996,602 and brazed-lead assembly by Patent No. 3,930,306

Patented***Features**

- Plastic package has Underwriters Laboratories Flammability Classification 94V-0
- High temperature metallurgically bonded construction
- Cavity-free glass passivated junction
- Capable of meeting environmental standards of MIL-S-19500
- 3.0 Ampere operation at $T_A=55^\circ\text{C}$ with no thermal runaway
- Typical I_R less than $0.1\mu\text{A}$
- High temperature soldering guaranteed: $350^\circ\text{C}/10$ seconds, 0.375" (9.5mm) lead length, 5 lbs. (2.3kg) tension

Mechanical Data**Case:** JEDEC DO-201AD, molded plastic over glass body**Terminals:** Plated axial leads, solderable per MIL-STD-750, Method 2026**Polarity:** Color band denotes cathode end**Mounting Position:** Any**Weight:** 0.04 oz., 1.12 g**Packaging Codes/Options:**

1/Bulk – 1.5K per container, 15K/box

4/1.4K per 13" reel, 5.6K/box

23/1K per ammo mag., 9K/box

Maximum Ratings & Thermal Characteristics Ratings at 25°C ambient temperature unless otherwise specified.

Parameter	Symbol	BY251GP	BY252GP	BY253GP	BY254GP	BY255GP	Unit
Maximum repetitive peak reverse voltage	V_{RRM}	200	400	600	800	1300	V
Maximum RMS voltage	V_{RMS}	140	280	420	560	910	V
Maximum DC blocking voltage	V_{DC}	200	400	600	800	1300	V
Maximum average forward rectified current 10mm lead length at $T_A = 55^\circ\text{C}$	$I_{F(AV)}$	3.0					A
Peak forward surge current 10ms single half sine-wave superimposed on rated load (JEDEC Method)	I_{FSM}	100					A
Maximum full load reverse current, full cycle average 10mm lead length at $T_A = 55^\circ\text{C}$	$I_{R(AV)}$	100					μA
Typical thermal resistance ⁽¹⁾	$R_{\theta JA}$	20					$^\circ\text{C}/\text{W}$
	$R_{\theta JL}$	10					
Operating junction and storage temperature range	T_J, T_{STG}	-65 to +175					$^\circ\text{C}$

Electrical Characteristics Ratings at 25°C ambient temperature unless otherwise specified.

Maximum instantaneous forward voltage at 3.0A	V_F	1.1					V
Maximum reverse current at rated DC blocking voltage $T_A = 25^\circ\text{C}$	I_R	5.0					μA
Typical reverse recovery time $I_F = 0.5\text{A}, I_R = 1.0\text{V}, I_{rr} = 0.25\text{A}$	t_{rr}	3.0					μs
Typical junction capacitance at 4.0V, 1MHz	C_J	40					pF

Note: (1) Thermal resistance from junction to ambient and from junction to lead at 0.375" (9.5mm) lead length, P.C.B. mounted

Ratings and Characteristic Curves ($T_A = 25^\circ\text{C}$ unless otherwise noted)

Fig 1 - Forward Current Derating Curve

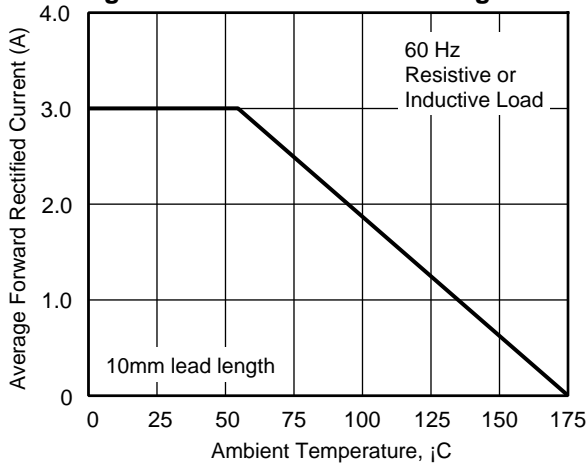

Fig 2 - Maximum Non-repetitive Peak Forward Surge Current

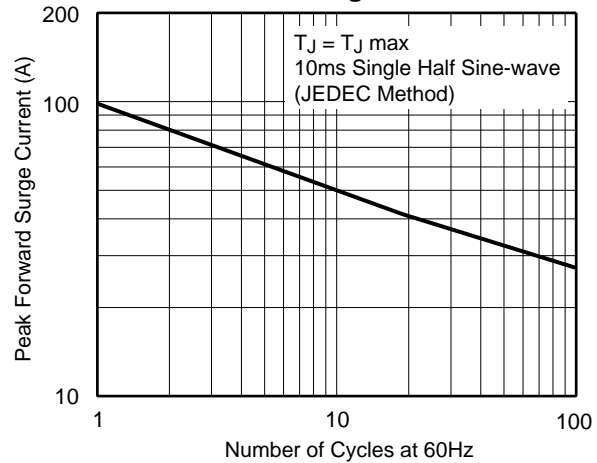

Fig 3 - Typical Instantaneous Forward Characteristics

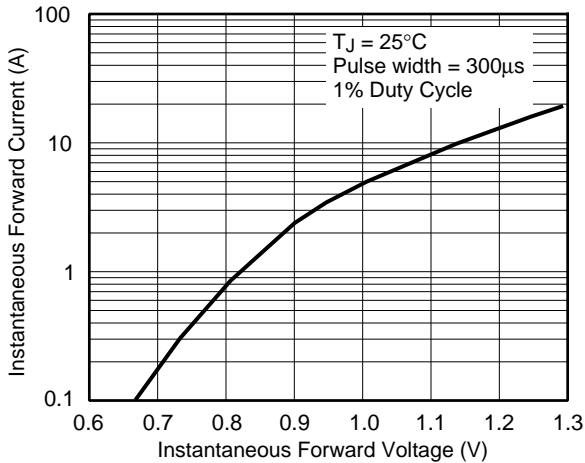

Fig 2 - Maximum Non-repetitive Peak Forward Surge Current

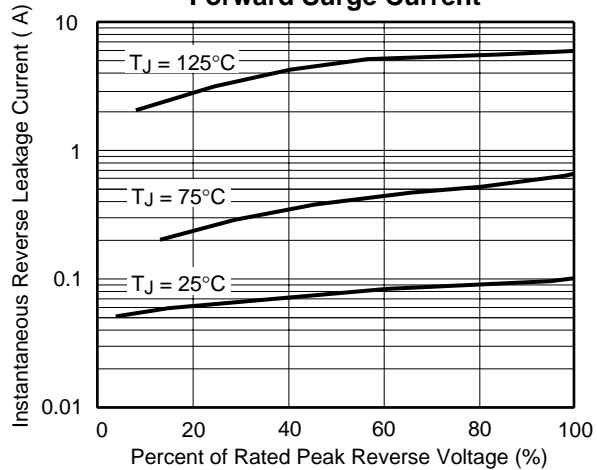
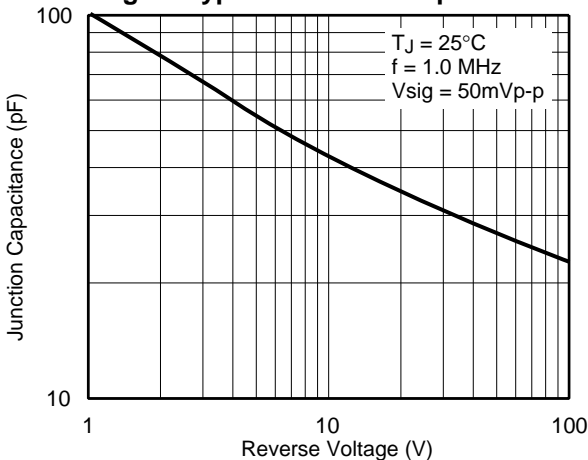

Fig 5 - Typical Junction Capacitance





LittleDiode supplies new, hard to find or obsolete electronic components and semiconductors all over the world.

With over two million different components listed you are sure to find the part you need.

Feel free to visit us today at our online store:

LittleDiode.com

Looking forward to providing you with the best possible service.