

## 2SA893, 2SA893A

SILICON PNP EPITAXIAL

LOW FREQUENCY HIGH VOLTAGE AMPLIFIER

Complementary pair with 2SC1890/A

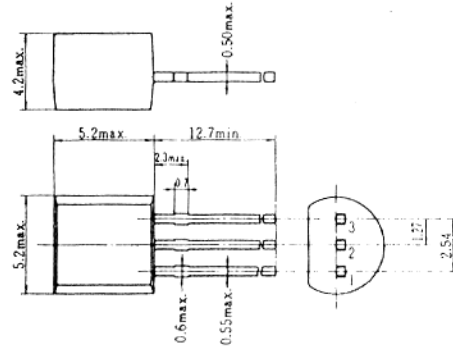

(JEDEC TO-92)

1. Emitter  
2. Collector  
3. Base  
(Dimensions in mm)

### ■ ABSOLUTE MAXIMUM RATINGS (Ta=25°C)

Item	Symbol	2SA893	2SA893A	Unit
Collector to base voltage	V <sub>CB0</sub>	-90	-120	V
Collector to emitter voltage	V <sub>CE0</sub>	-90	-120	V
Emitter to base voltage	V <sub>EB0</sub>	-5	-5	V
Collector current	I <sub>C</sub>	-50	-50	mA
Collector power dissipation	P <sub>C</sub>	300	300	mW
Junction temperature	T <sub>J</sub>	150	150	°C
Storage temperature	T <sub>stg</sub>	-55 to +150	-55 to +150	°C

### MAXIMUM COLLECTOR DISSIPATION CURVE

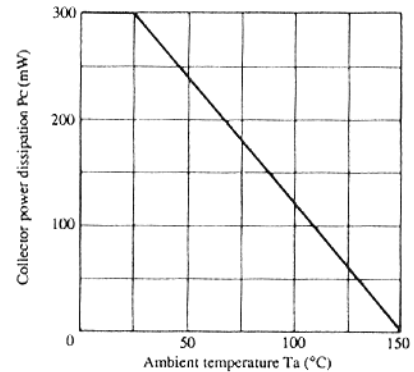

### ■ ELECTRICAL CHARACTERISTICS (Ta=25°C)

Item	Symbol	Test Condition	2SA893			2SA893A			Unit
			min.	typ.	max.	min.	typ.	max.	
Collector to emitter break-down voltage	V <sub>(BR)CEO</sub>	I <sub>C</sub> = -1mA, R <sub>BE</sub> = ∞	-90	—	—	-120	—	—	V
Collector cutoff current	I <sub>CBO</sub>	V <sub>CB</sub> = -75V, I <sub>E</sub> = 0	—	—	-0.5	—	—	—	μA
		V <sub>CB</sub> = -100V, I <sub>E</sub> = 0	—	—	—	—	—	-0.5	
DC current transfer ratio	h <sub>FE</sub> *	V <sub>CE</sub> = -12V, I <sub>C</sub> = -2mA	250	—	800	250	—	800	
Base to emitter voltage	V <sub>BE</sub>	V <sub>CE</sub> = -12V, I <sub>C</sub> = -2mA	—	—	-0.75	—	—	-0.75	V
Collector to emitter saturation voltage	V <sub>CE(sat)</sub>	I <sub>C</sub> = -10mA, I <sub>B</sub> = -1mA	—	—	-0.5	—	—	-0.5	V
Gain bandwidth product	f <sub>T</sub>	V <sub>CE</sub> = -12V, I <sub>C</sub> = -2mA	—	120	—	—	120	—	MHz
Collector output capacitance	C <sub>ob</sub>	V <sub>CB</sub> = -25V, I <sub>E</sub> = 0, f = 1MHz	—	1.8	—	—	1.8	—	pF
Noise figure	NF	V <sub>CE</sub> = -6V, I <sub>C</sub> = -50μA R <sub>g</sub> = 50kΩ, f = 1kHz	—	2	10	—	2	10	dB

\* The 2SA893/A is grouped by h<sub>FE</sub> as follows.

D	E
250 to 500	400 to 800

■ See characteristic curves of 2SA872 and 2SA872A.