

FEATURES

- On-State Current, 300 mA
- Zero Voltage Crossing
- Blocking Voltage, 600 V
- Isolation Test Voltage from Double Molded Package, 5300 VAC_{RMS}
- High Input Sensitivity
I_{FT}=2 mA, PF=1.0
I_{FT}=5 mA, PF≤1.0
- High Static dv/dt 10,000 V/μs
- Inverse Parallel SCRs Provide Commutating dv/dt >10K V/μs
- Very Low Leakage <10 μA
- Small 6-Pin DIP Package
- Underwriters Lab File #E52744
- VDE Approval #0884 (Optional with Option 1, Add -X001 Suffix)

Maximum Ratings

Emitter

Reverse Voltage	6 V
Forward Current	60 mA
Surge Current	2.5 A
Thermal Resistance	750 °C/W
Power Dissipation	100 mW
Derate from 25°C	1.33 mW/°C

Detector

Peak Off-State Voltage	600 V
Peak Reverse Voltage	600 V
RMS On-State Current	300 mA
Single Cycle Surge	3 A
Thermal Resistance	125°C/W
Total Power Dissipation	500 mW
Derate from 25°C	6.6 mW/°C

Package

Isolation Test Voltage	5300 VAC _{RMS}
Storage Temperature	-55°C to +150°C
Operating Temperature	-55°C to +100°C
Lead Soldering Temperature	260°C/5 sec.

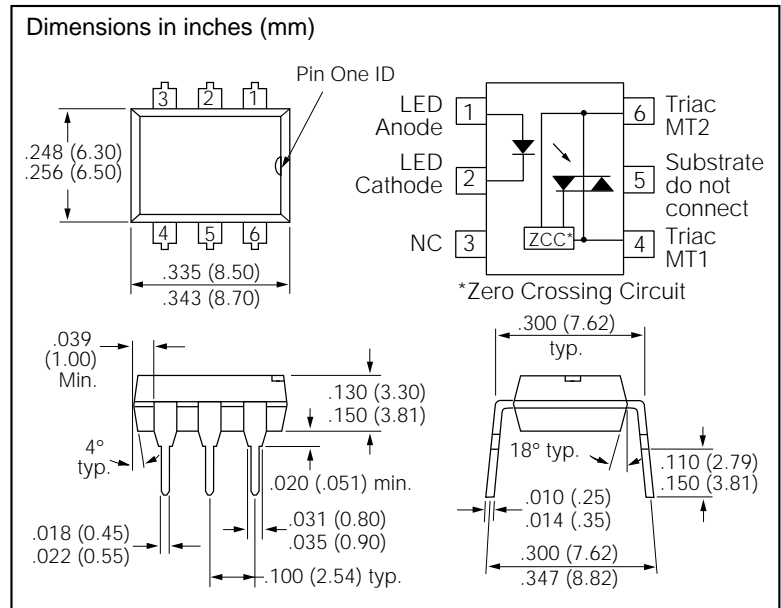

DESCRIPTION

The IL410 consists of a GaAs IRLED optically coupled to a photosensitive zero crossing TRIAC network. The TRIAC consists of two inverse parallel connected monolithic SCRs. These three semiconductors are assembled in a six pin 0.3 inch dual in-line package, using high insulation double molded, over/under leadframe construction.

High input sensitivity is achieved by using an emitter follower phototransistor and a cascaded SCR predriver resulting in an LED trigger current of less than 2 mA (DC).

The IL410 uses two discrete SCRs resulting in a commutating dv/dt greater than 10KV/μs. The use of a proprietary dv/dt clamp results in a static dv/dt of greater than 10KV/μs. This clamp circuit has a MOSFET that is enhanced when high dv/dt spikes occur between MT1 and MT2 of the TRIAC. When conducting, the FET clamps the base of the phototransistor, disabling the first stage SCR predriver.

The zero cross line voltage detection circuit consists of two enhancement MOSFETS and a photodiode. The inhibit voltage of the network is determined by the enhancement voltage of the N-channel FET. The P-channel FET is enabled by a photocurrent source that permits the FET to conduct the main voltage to gate on the N-channel FET. Once the main voltage can enable the N-channel, it clamps the base of the phototransistor, disabling the first stage SCR predriver.

The 600V blocking voltage permits control of off-line voltages up to 240VAC, with a safety factor of more than two, and is sufficient for as much as 380VAC.

The IL410 isolates low-voltage logic from 120, 240, and 380 VAC lines to control resistive, inductive, or capacitive loads including motors, solenoids, high current thyristors or TRIAC and relays.

Applications include solid-state relays, industrial controls, office equipment, and consumer appliances.

Characteristics

	Symbol	Min	Typ	Max	Unit	Condition
Emitter						
Forward Voltage	V_F		1.16	1.35	V	$I_F=10\text{ mA}$
Reverse Current	I_R		0.1	10	μA	$V_R=6\text{ V}$
Capacitance	C_O		25		pF	$V_F=0\text{ V}$, $f=1\text{ MHz}$
Thermal Resistance, Junction to Lead	R_{THJL}		750		$^{\circ}\text{C/W}$	
Output Detector						
Off-State Voltage	$V_{D(RMS)}$	424	460		V	$I_{D(RMS)}=70\text{ mA}$
Off-State Current	$I_{D(RMS)1}$		10	100	μA	$V_D=600\text{ V}$, $T_A=100^{\circ}\text{C}$, $I_F=0\text{ mA}$
Off State Current	$I_{D(RMS)2}$			200	μA	$V_D=600\text{ V}$, $I_F=\text{Rated } I_{FT}$
On-State Voltage	V_{TM}		1.7	3	V	$I_T=300\text{ mA}$
On State Current	I_{TM}			300	mA	$\text{PF}=1.0$, $V_{T(RMS)}=1.7\text{ V}$
Surge (Non-Repititive), On-State Current	I_{TSM}			3	A	$f=50\text{ Hz}$
Trigger Current 1	I_{FT1}			2.0	mA	$V_D=5\text{ V}$
Trigger Current 2	I_{FT2}			6.0	mA	$V_{OP}=220\text{ V}$, $f=50\text{ Hz}$, $T_j=100^{\circ}\text{C}$, $t_{pF}>10\text{ ms}$
Trigger Current Temp. Gradient	$\frac{\Delta I_{FT1}}{\Delta T_j}$ $\frac{\Delta I_{FT2}}{\Delta T_j}$		7 7	14 14	$\mu\text{A/K}$ $\mu\text{A/K}$	
Inhibit Voltage Temp. Gradient	$\Delta V_{DINH}/\Delta T_j$		-20		mV/K	
Off-State Current in Inhibit State	I_{DINH}		50	200	μA	$I_F=I_{FT1}$, V_{DRM}
Capacitance Between Input and Output Circuit	C_{IO}		2.0		pF	$V_D=0$, $f=1\text{ kHz}$
Holding Current	I_H		65	500	μA	
Latching Current	I_L		5		mA	$V_T=2.2\text{ V}$
Zero Cross Inhibit Voltage	V_{IH}		15	25	V	$I_F=\text{Rated } I_{FT}$
Turn-On Time	t_{ON}		35		μs	$V_{RM}=V_{DM}=424\text{ VAC}$
Turn-Off Time	t_{OFF}		50		μs	$\text{PF}=1.0$, $I_T=300\text{ mA}$
Critical Rate of Rise of Off-State Voltage	dv/dt_{cr} dv/dt_{cr}	10000 5000			V/ μs V/ μs	$V_D=0.67\text{ V}_{DRM}$, $T_j=25^{\circ}\text{C}$ $T_j=80^{\circ}\text{C}$
Critical Rate of Rise of Voltage at Current Commutation	dv/dt_{crq} dv/dt_{crq}	10000 5000			V/ μs V/ μs	$V_D=0.67\text{ V}_{DRM}$, $di/dt_{crq} \leq 15\text{ A/ms}$ $T_j=25^{\circ}\text{C}$ $T_j=80^{\circ}\text{C}$
Critical Rate of Rise of On-State Current	di/dt_{cr}			8	A/ms	
Thermal Resistance, Junction to Lead	R_{THJL}		150		$^{\circ}\text{C/W}$	
Insulation and Isolation						
Critical Rate of Rise of Coupled Input/Output Voltage	$dv_{(IO)}/dt$		10000		V/ μs	$I_T=0\text{ A}$, $V_{RM}=V_{DM}=424\text{ VAC}$
Common Mode Coupling Capacitor	C_{CM}		0.01		pF	
Packing Capacitance	C_{IO}		0.8		pF	$f=1\text{ MHz}$, $V_{IO}=0\text{ V}$
Isolation Test Voltag, Input-Output	V_{ISO}	5300			VAC _{RMS}	Relative Humidity $\leq 50\%$
Creepage		≥ 7			mm	
Clearance		≥ 7			mm	
Creepage Tracking Resistance per DIN IEC 112/VDE 0303, Part 1 Group IIIa per DIN VDE 10110	CTI		175			
Isolation Resistance	R_{IS} R_{IS}		$\geq 10^{12}$ $\geq 10^{11}$		Ω Ω	$V_{IO}=500\text{ V}$ $T_A=25^{\circ}\text{C}$ $T_A+100^{\circ}\text{C}$

Power Factor Considerations

A snubber isn't needed to eliminate false operation of the TRIAC driver because of the IL410's high static and commutating dv/dt with loads between 1 and 0.8 power factors. When inductive loads with power factors less than 0.8 are being driven, include a RC snubber or a single capacitor directly across the device to damp the peak commutating dv/dt spike. Normally a commutating dv/dt causes a turning-off device to stay on due to the stored energy remaining in the turning-off device.

But in the case of a zero voltage crossing optotriac, the commutating dv/dt spikes can inhibit one half of the TRIAC from turning on. If the spike potential exceeds the inhibit voltage of the zero cross detection circuit, half of the TRIAC will be held-off and not turn-on. This hold-off condition can be eliminated by using a snubber or capacitor placed directly across the optotriac as shown in Figure 1. Note that the value of the capacitor increases as a function of the load current.

Figure 1. Shunt capacitance versus load current

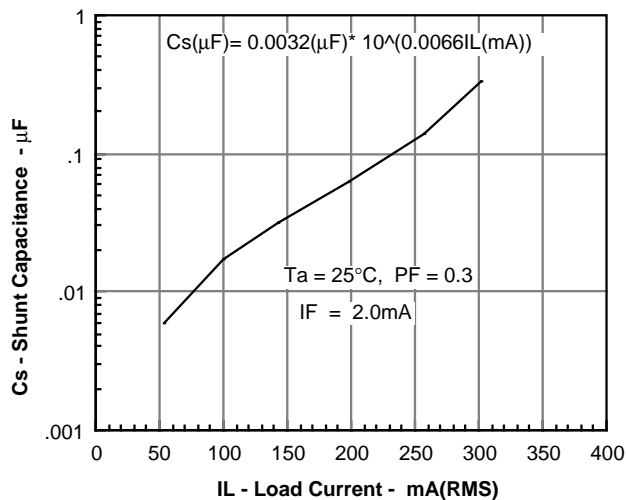

The hold-off condition also can be eliminated by providing a higher level of LED drive current. The higher LED drive provides a larger photocurrent which causes the phototransistor to turn-on before the commutating spike has activated the zero cross network. Figure 2 shows the relationship of the LED drive for power factors of less than 1.0. The curve shows that if a device requires 1.5 mA for a resistive load, then 1.8 times (2.7 mA) that amount would be required to control an inductive load whose power factor is less than 0.3.

Figure 2. Normalized LED trigger current versus power factor

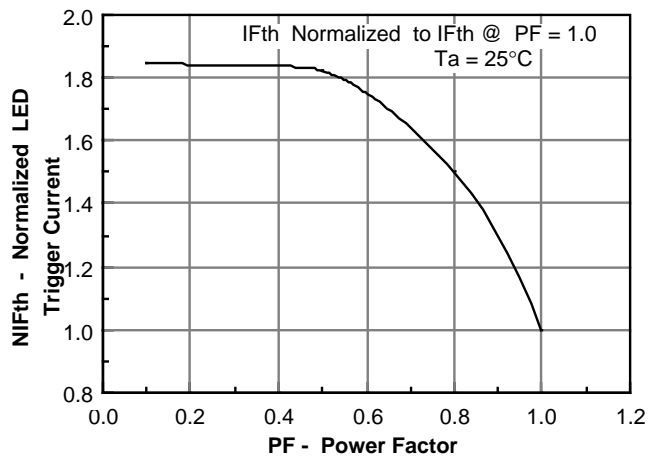

Figure 3. Forward voltage versus forward current

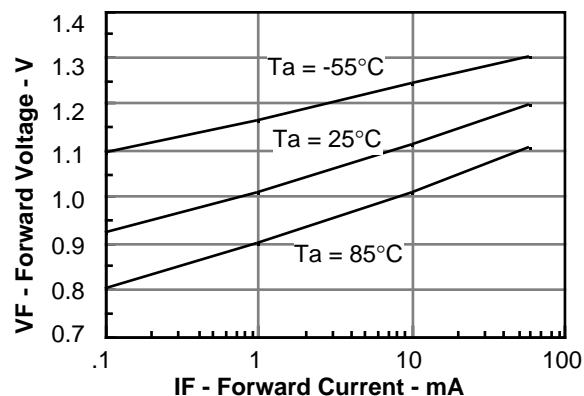

Figure 4. Peak LED current versus duty factor, Tau

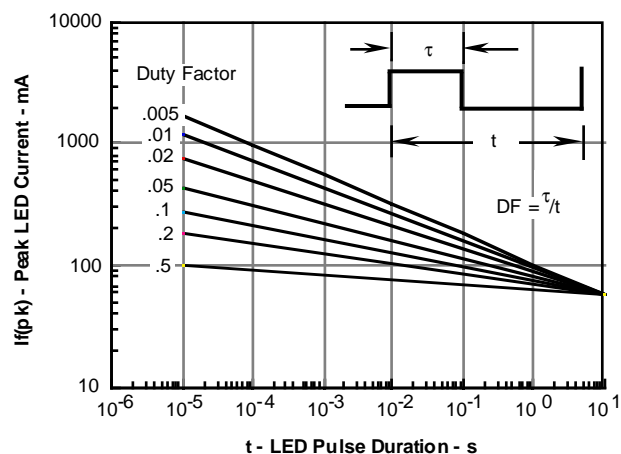

Figure 5. Maximum LED power dissipation

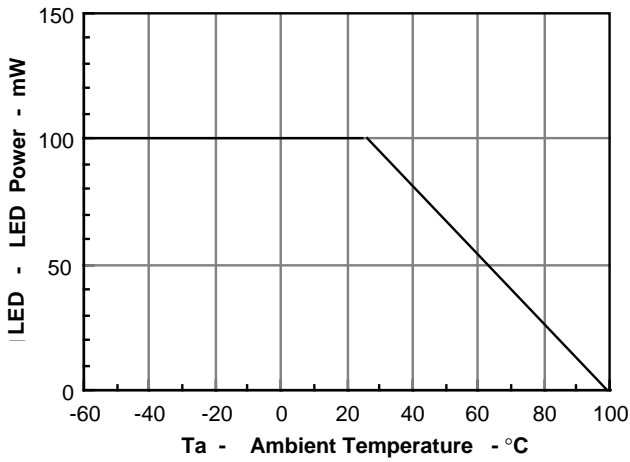

Figure 6. Typical output characteristics

$I_T = f(V_T)$, parameter: T_j

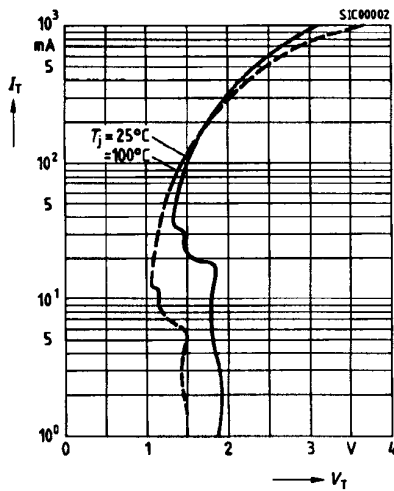

Figure 7. Current reduction

$I_{TRMS} = f(T_A)$, $R_{thJA} = 125 \text{ K/W}$
Device switch soldered in pcb or base plate.

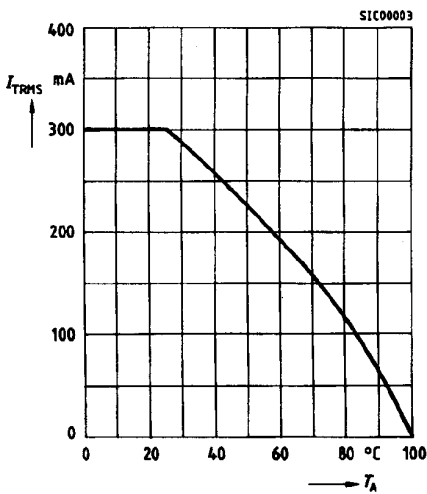

Figure 8. Current reduction

$I_{TRMS} = f(T_{PIN5})$, $R_{thJ-PIN5} = 16.5 \text{ K/W}$
Thermocouple measurement must be performed potentially separated to A1 and A2. Measuring junction as near as possible at the case.

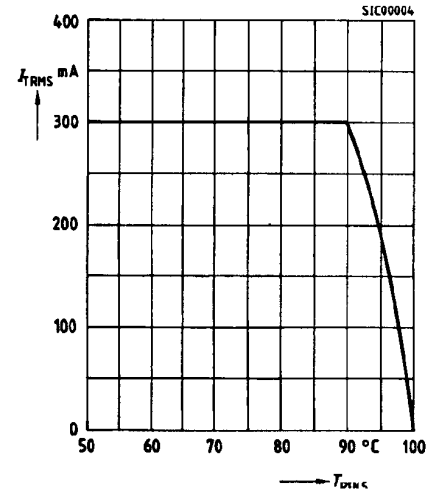

Figure 9. Typical trigger delay time

$t_{gd} = f(I_F / I_{FT25^\circ C})$, $V_D = 200 \text{ V}$, $f = 40 \text{ to } 60 \text{ Hz}$,
parameter: T_j

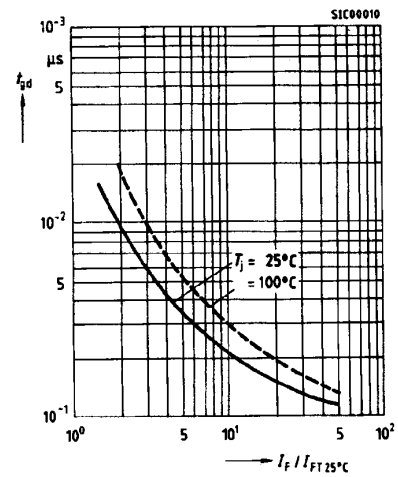

Figure 10. Typical inhibit current

$I_{DINH} = f(I_F / I_{FT25^\circ C})$
 $V_D = 600 \text{ V}$, parameter: T_j

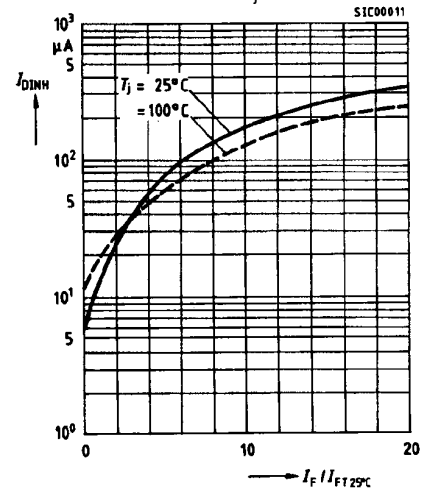

Figure 11. Power dissipation 40 to 60 Hz line operation, $P_{TOT}=f(I_{TRMS})$

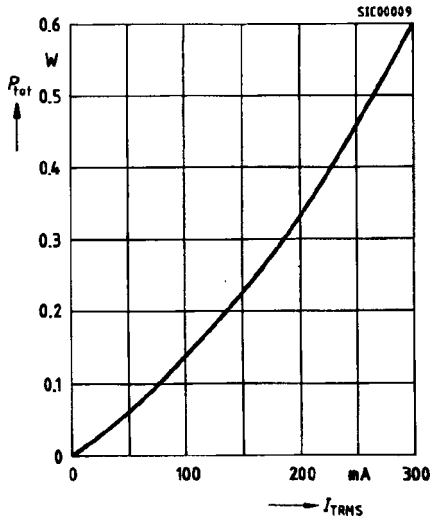
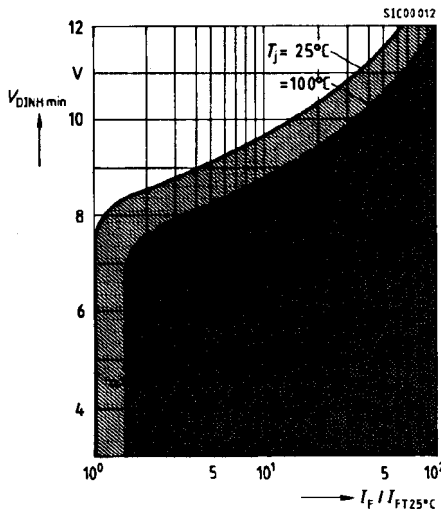

Figure 12. Typical static inhibit voltage limit

$V_{DINHmin} = f(I_F/I_{FT25^{\circ}C})$, parameter: T_j
 Device zero voltage switch can be triggered only in hatched area below T_j curves.



Current commutation:

The values 100 A/ms with following peak reverse recovery current >80 mA should not be exceeded.

Avoiding high-frequency turn-off current oscillations:

This effect can occur when switching a circuit. Current oscillations which appear essentially with inductive loads of a higher winding capacity result in current commutation and can generate a relatively high peak reverse recovery current. The following alternating protective measures are recommended for the individual operating states:

1—Apply a capacitor to the supply pins at the load-side.

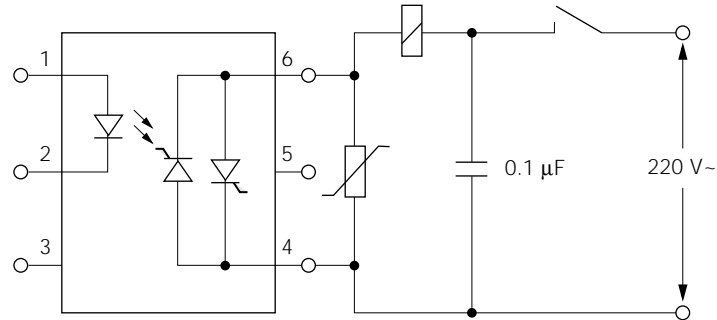

2— Connect a series resistor to the IL410 output and bridge both by a capacitor.

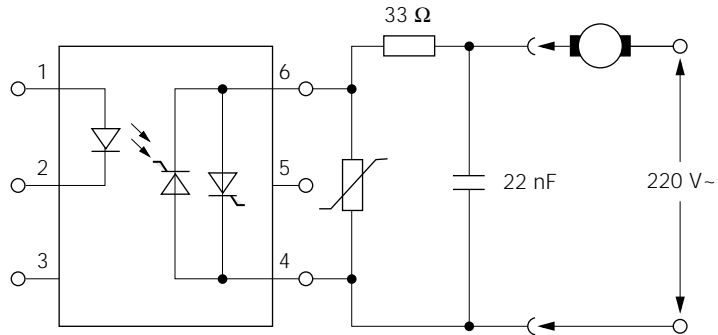

3—Connect a choke of low winding capacity in series, e.g., a ringcore choke, with higher load currents.

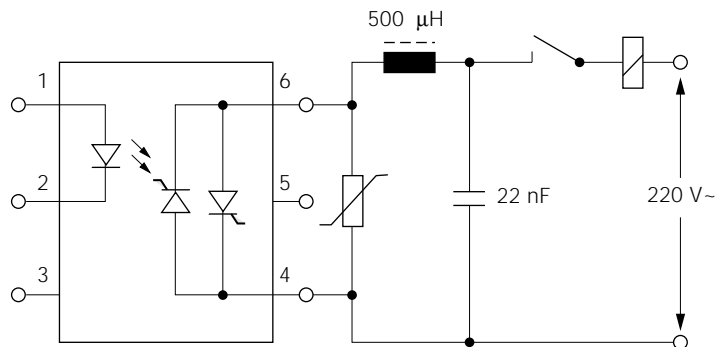

Note:

Measures 2 to 3 are especially required for the load separated from the IL410 during operation. The above mentioned effects do not occur with IL410 circuits which are connected to the line by transformers and which are not mechanically interrupted. In such cases as well as in applications with a resistive load the corresponding protective circuits can be neglected.

Technical Information

Commutating Behavior

The use of a triac at the output creates difficulties in commutation due to both the built-in coupled thyristor systems. The triac can remain conducting by parasitic triggering after turning off the control current. However, if the IL410 is equipped with two separate thyristor chips featuring high dv/dt strength, no RC circuit is needed in case of commutation.

Control And Turn-On Behavior

The trigger current of the IL410 has a positive temperature gradient. The time which expires from applying the control current to the turn-on of the load current is defined as the trigger delay time (t_{gd}). On the whole this is a function of the overdrive meaning the ratio of the applied control current versus the trigger current (I_F/I_{FT}). If the value of the control current corresponds to that of the individual trigger current of IL410 turn-on delay times amounts to a few milliseconds only. The shortest times of 5 to 10 μs can be achieved for an overdrive greater or equal than 10. The trigger delay time rises with an increase in temperature.

For very short control current pulses ($t_{pIF} < 500 \mu s$) a correspondingly higher control current must be used. Only the IL410 without zero voltage switch is suitable for this operating mode.

Zero Voltage Switch

The IL410 with zero voltage switch can only be triggered during the zero crossing the sine AC voltage. This prevents current spikes, e. g. when turning-on cold lamps or capacitive loads.

Applications

Direct switching operation: The IL410 switch is mainly suited to control synchronous motors, valves, relays and solenoids in Grätz circuits. Due to the low latching current (500 μA) and the lack of an RC circuit at the output, very low load currents can easily be switched.

Indirect switching operation: The IL410 switch acts here as a driver and thus enables the driving of thyristors and triacs of higher performance by microprocessors. The driving current pulse should not exceed the maximum permissible surge current of the IL410. For this reason, the IL410 without zero voltage switch often requires current limiting by a series resistor.

The favorably low latching current in this operating mode results in AC current switches which can handle load currents from some milliamperes up to high currents.

Application Note

- Over voltage protection: A voltage-limiting varistor (e.g. SIO VS05K250) which directly connected to the IL410 can protect the component against overvoltage.



LittleDiode supplies new, hard to find or obsolete electronic components and semiconductors all over the world.

With over two million different components listed you are sure to find the part you need.

Feel free to visit us today at our online store:

LittleDiode.com

Looking forward to providing you with the best possible service.