

DESCRIPTION

The CNW82, CNW83, CNW84 and CNW85 optocouplers consist of a GaAs infrared emitting diode which is optically coupled to an NPN phototransistor.

The CNW82 and CNW84 do not have the base pin connected for improved noise immunity.

FEATURES

- Wide body DIL encapsulation, with a pin distance of 10.16 mm.
- Minimum creepage distance 10 mm.
- High current transfer ratio and Low Saturation Voltage, making the device suitable for use with TTL integrated circuits.
- High degree of AC and DC insulation (5900 V (RMS) and 8340 V (DC)).
- Minimum 2 mm isolation thickness between emitter and detector. (CNW84/85 only).
- An external clearance of 9.6 mm minimum and an external creepage distance of 10 mm minimum.
- Collector-Emitter Breakdown Voltage: 50 V (CNW82/83 only).
- Collector-Emitter Breakdown Voltage: 80 V (CNW84/85 only).
- UL recognized (File # E90700)

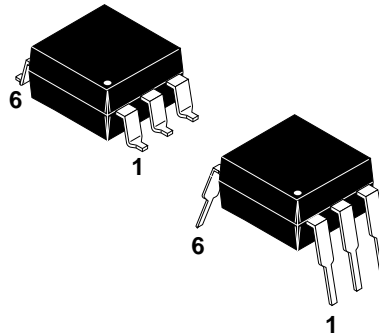

CNW82
CNW83
CNW84
CNW85

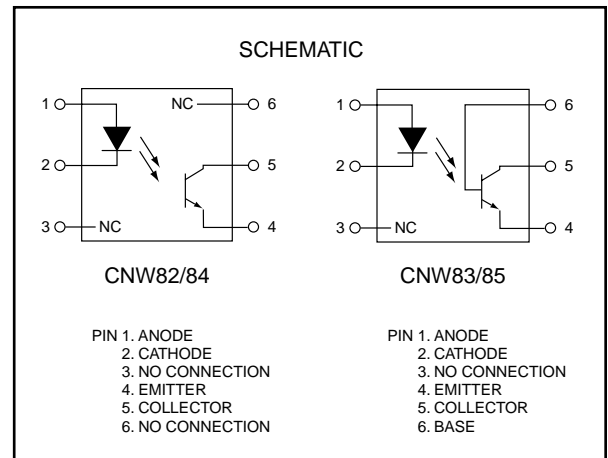

ABSOLUTE MAXIMUM RATINGS

Parameter	Symbol	Value	Units
EMITTER			
Forward Current - Continuous	I_F	100	mA
Forward Current - Peak (PW = 100 μ s, 120pps)	$I_F(pk)$	3	A
Reverse Voltage	V_R	5	V
Total Power Dissipation @ $T_A = 25^\circ\text{C}$	P_D	200	mW
Derate above 25 $^\circ\text{C}$		2.0	mW/ $^\circ\text{C}$
DETECTOR			
Collector Current-Continuous	I_C	100	mA
Emitter-Collector Voltage	V_{ECO}	7	V
Collector-Emitter Voltage	V_{CEO}	50	V
(CNW82/CNW83)		80	
Collector-Base Voltage	V_{CBO}	70	V
(CNW85)		120	
Total Power Dissipation @ $T_A = 25^\circ\text{C}$	P_D	200	mW
Derate above 25 $^\circ\text{C}$		2.0	mW/ $^\circ\text{C}$
TOTAL DEVICE			
Storage Temperature Range	T_{stg}	-55 to 150	$^\circ\text{C}$
Ambient Operating Temperature Range	T_A	-40 to 100	$^\circ\text{C}$
Lead Soldering Temperature (1/16" from case, 10 sec. duration)	T_L	260	$^\circ\text{C}$

CNW82, CNW83, CNW84, CNW85

ELECTRICAL CHARACTERISTICS ($T_A = 25^\circ\text{C}$ Unless otherwise specified)						
Parameter	Test Conditions	Symbol	Min	Typ	Max	Unit
EMITTER						
Input Forward Voltage	$(I_F = 10 \text{ mA})$	V_F	—	1.20	1.50	V
Reverse Leakage Current	$(V_R = 5.0 \text{ V})$	I_R	—	—	10	μA
DETECTOR						
Collector-Emitter Breakdown Voltage	$(I_C = 1.0 \text{ mA})$	BV_{CEO}	50	100	—	V
Emitter-Collector Breakdown Voltage	$(I_E = 0.1 \text{ mA})$	BV_{ECO}	7	10	—	V
Collector-Base Breakdown Voltage	$(I_C = 0.1 \text{ mA})$	BV_{CBO}	70	100	—	V
Collector-Emitter Dark Current	$(V_{CE} = 10 \text{ V}, I_F = 0)$	I_{CEO}	—	1	50	nA
Collector-Base Cut-off Current	$(V_{CB} = 10 \text{ V}, I_F = 0)$	I_{CBO}	—	—	20	nA
COUPLED						
Collector-Emitter Saturation Voltage	$(I_C = 4 \text{ mA}, I_F = 10 \text{ mA})$	$V_{CE(sat)}$	—	0.15	0.4	V
Isolation Voltage	$(t = 1.0 \text{ min.})^{(1)}$	V_{ISO}	8.34	—	—	kV
Isolation Resistance	$(V_{I-O} = 500 \text{ V})$	R_{ISO}	1	10	—	$\text{T}\Omega$
Isolation Capacitance	$(V_{I-O} = 0, f = 1.0 \text{ MHz})$	C_{ISO}	—	0.4	1	pF
Current Transfer Ratio	$(I_F = 10 \text{ mA}, V_{CE} = 0.4 \text{ V})$	CTR	0.4	0.8	—	%
Capacitance	$(V_{CB} = 10 \text{ V}, f = 1 \text{ MHz})$	C_{CB}	—	4.5	—	pF
Turn-on Time	$(I_C = 2 \text{ mA}, V_{CC} = 5 \text{ V}, R_L = 100 \Omega)$	T_{ON}	—	3	—	μs
Turn-off Time	$(I_C = 2 \text{ mA}, V_{CC} = 5 \text{ V}, R_L = 1 \text{ k}\Omega)$	T_{OFF}	—	12	—	μs

NOTE:

1. Every product is tested with pins 1, 2 and 3 shorted together, and pins 4, 5 and 6 shorted together.

CNW82, CNW83, CNW84, CNW85

Fig. 1 Forward Current vs. Forward Voltage

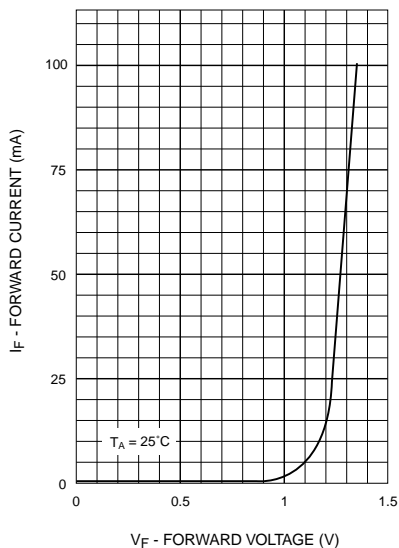

Fig. 2 Collector Current vs. Forward Current (for CNW84 and CNW85)

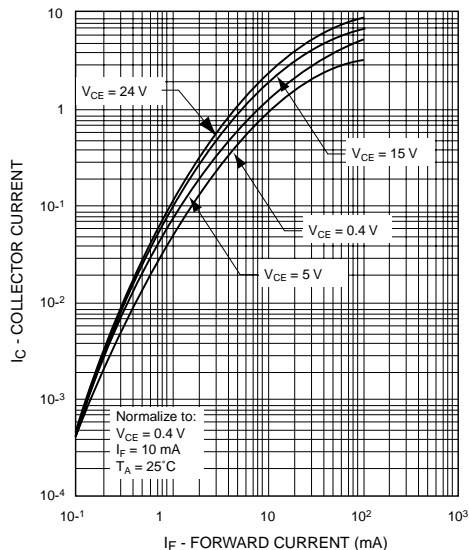

Fig. 3 Collector Current vs. Forward Current (for CNW82 and CNW83)

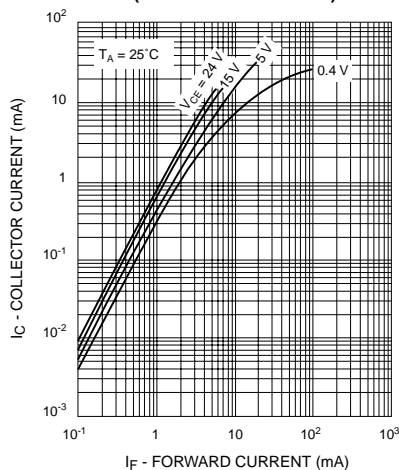

Fig. 4 Collector Current vs. Collector-Emitter Voltage

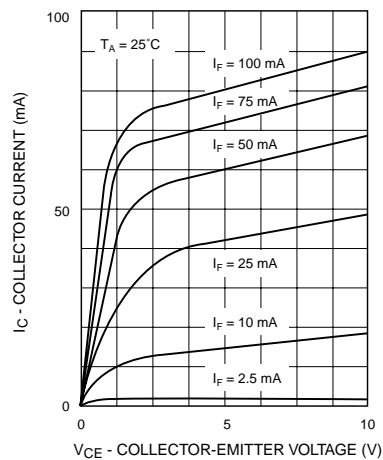

Fig. 5 Collector Current vs. Ambient Temperature (for CNW82 and CNW83)

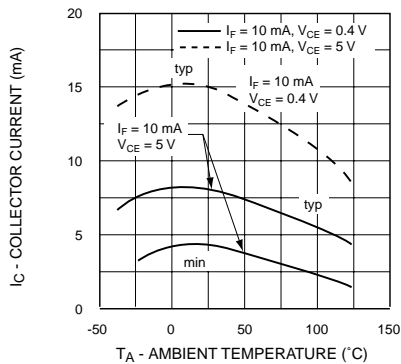
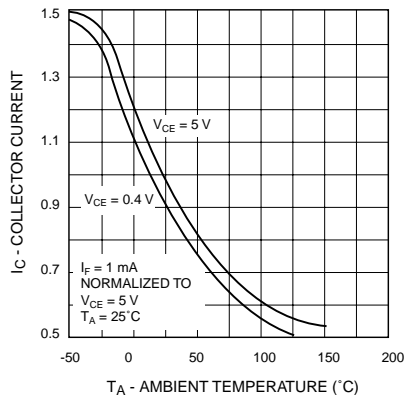

Fig. 6 Collector Current vs. Ambient Temperature (for CNW84 and CNW85)



CNW82, CNW83, CNW84, CNW85

Fig. 7 Collector Current vs. Ambient Temperature (for CNW84 and CNW85)

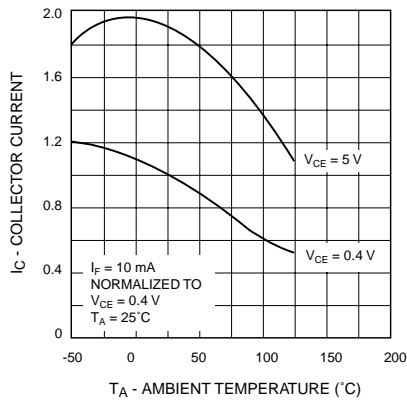

Fig. 8 Collector-Emitter Dark Current vs. Junction Temperature

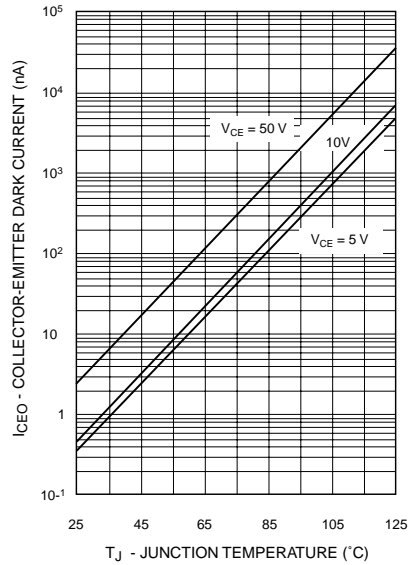

Fig. 9 Collector-Emitter Saturation Voltage vs. Collector Current

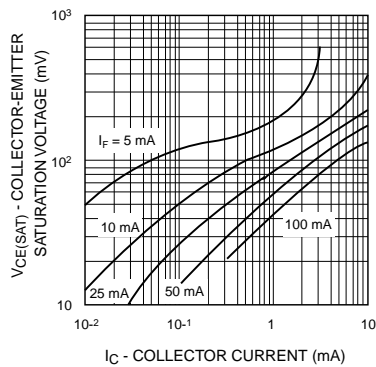
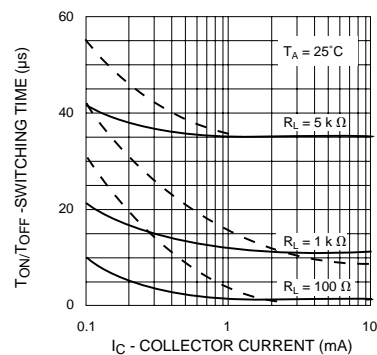
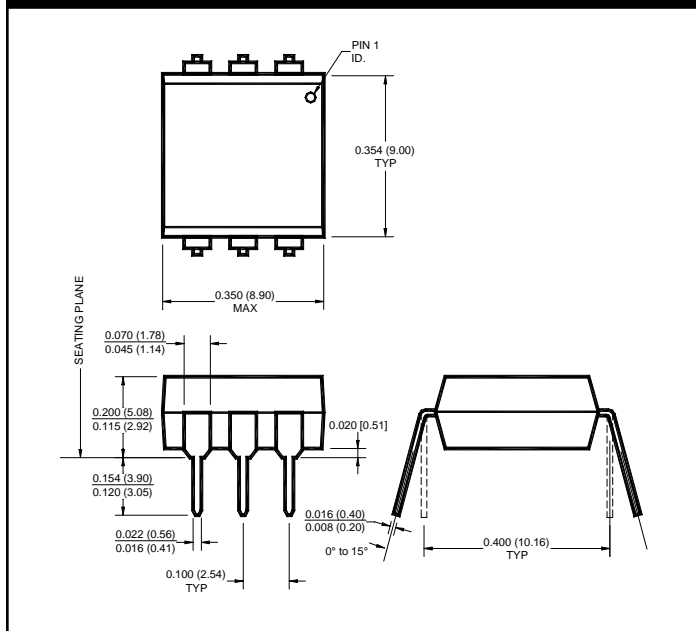

Fig. 10 Rise and Fall Time vs. Collector Current



CNW82, CNW83, CNW84, CNW85

Package Dimensions (Through Hole)



Package Dimensions (Surface Mount)

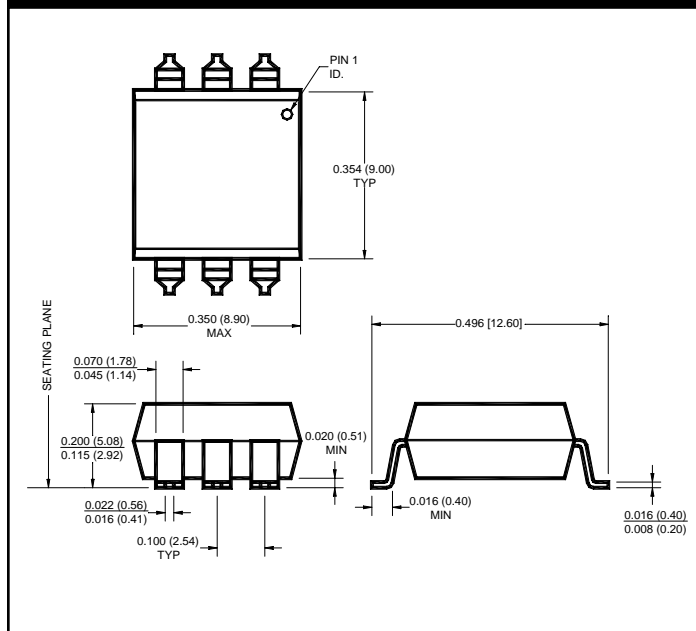

NOTE

All dimensions are in inches (millimeters)

Call QT Optoelectronics for more information or the phone number of your nearest distributor.

United States 800-533-6786 • France 33 [0] 1.45.18.78.78 • Germany 49 [0] 89/96.30.51 • United Kingdom 44 [0] 1296 394499 • Asia/Pacific 603-7352417



LittleDiode supplies new, hard to find or obsolete electronic components and semiconductors all over the world.

With over two million different components listed you are sure to find the part you need.

Feel free to visit us today at our online store:

LittleDiode.com

Looking forward to providing you with the best possible service.