

25 Amp Schottky Rectifiers 1N5829 — 1N5831

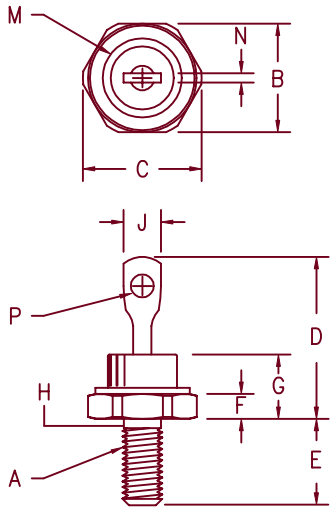

- Notes:
 1. 10–32 UNF3A threads
 2. Full threads within 2 1/2 threads Standard Polarity: Stud is Cathode

Dim.	Inches		Millimeter		Notes
	Minimum	Maximum	Minimum	Maximum	
A	---	---	---	---	1
B	.424	.437	10.77	11.10	
C	---	.505	---	12.82	
D	.600	.800	15.24	20.32	
E	.422	.453	10.72	11.50	
F	.075	.175	1.91	4.44	
G	---	.405	---	10.29	
H	.163	.189	4.15	4.80	2
J	---	.250	---	6.35	
M	---	.350	---	8.89	Dia.
N	.020	.065	.510	1.65	
P	.060	.100	1.53	2.54	Dia.

D0203AA (D04)

Microsemi Catalog Number	Working Peak Reverse Voltage	Repetitive Peak Reverse Voltage
1N5829	20V	20V
1N5830	30V	30V
1N5831	40V	40V

- Schottky Barrier Rectifier
- Guard ring protection
- Low forward voltage drop
- 25 Amperes
- 125°C Junction Temperature
- VRRM 20 to 40 volts

Electrical Characteristics

		1N5829	1N5830	1N5831	
Average forward current	I _{F(AV)}	25A	25A	25A	T _C = 97°C, square wave, R _{θJC} = 1.75°C/W
Maximum surge current	I _{FSM}	800A	800A	800A	8.3ms, half sine, T _J = 125°C
Max peak forward voltage	V _{FM}	.360V	.370V	.380V	I _{FM} = 10A; T _J = 25°C*
Max peak forward voltage	V _{FM}	.440V	.460V	.480V	I _{FM} = 25A; T _J = 25°C*
Max peak forward voltage	V _{FM}	.720V	.770V	.820V	I _{FM} = 78.5A; T _J = 25°C*
Max peak reverse current	I _{RM}	150mA	150mA	150mA	V _{RRM, T_J} = 100°C
Max peak reverse current	I _{RM}	3.0mA	3.0mA	3.0mA	V _{RRM, T_J} = 25°C
Typical junction capacitance	C _J	1650pF	1650pF	1650pF	T _J = 25°C, V _R = 5V, f = 1MHz

*Pulse test: Pulse width 300 μsec, Duty cycle 2%

Thermal and Mechanical Characteristics

Storage temperature range	T _{STG}	-65°C to 125°C
Operating junction temp range	T _J	-65°C to 125°C
Maximum thermal resistance	R _{θJC}	1.75°C/W junction to case
Typical thermal resistance	R _{θJS}	0.5°C/W junction to sink
Mounting torque		15 inch pounds maximum
Weight		6 grams (.02 ounces) typical

3-7-00 Rev. 2

1N5829-1N5831

Figure 1
Typical Forward Characteristics

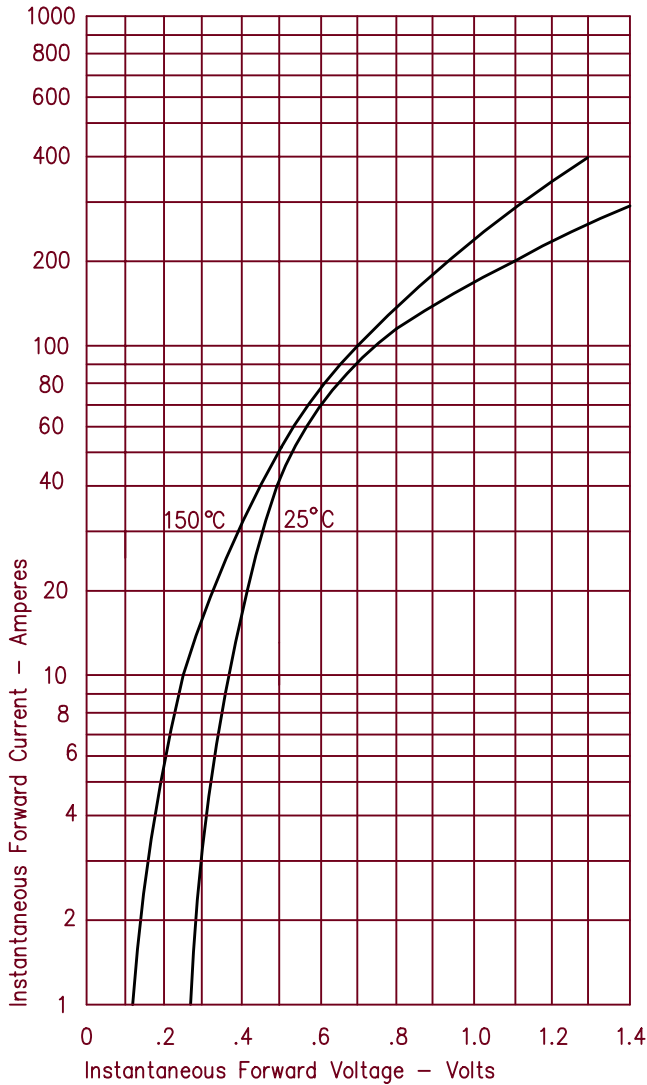

Figure 3
Typical Junction Capacitance

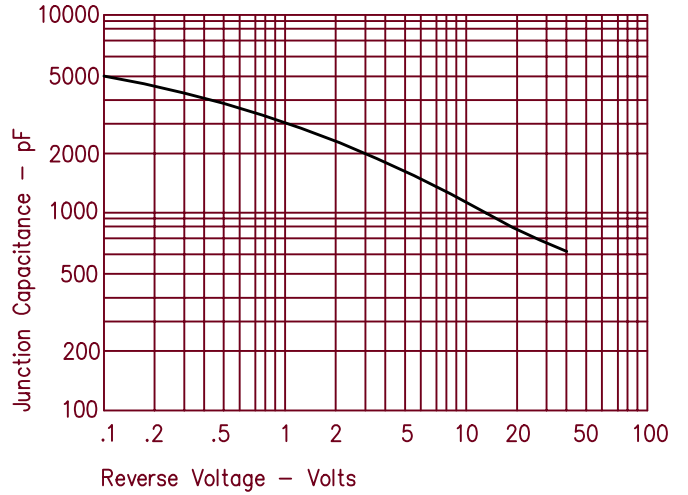

Figure 4
Maximum Forward Power Dissipation

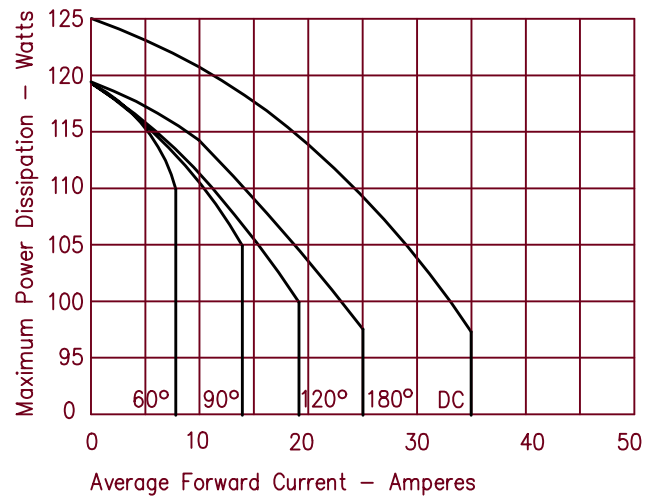

Figure 2
Typical Reverse Characteristics

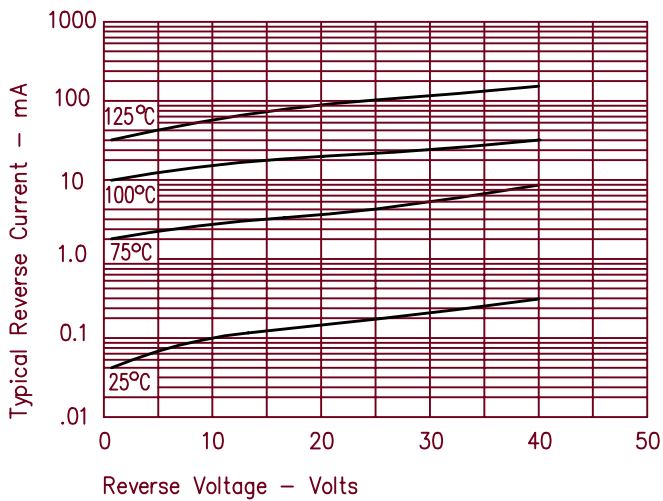
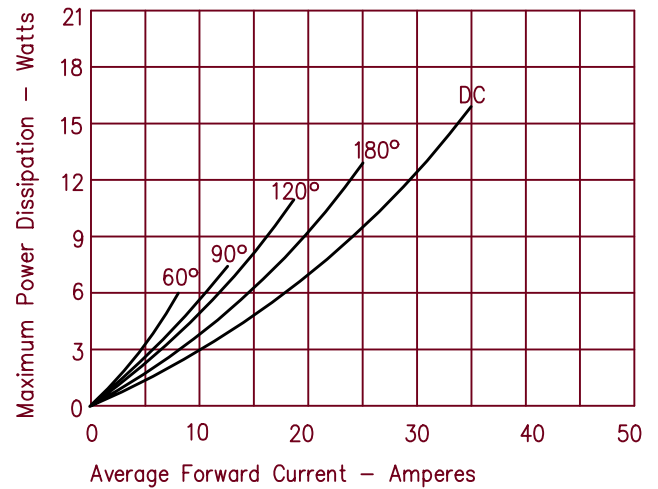

Figure 5
Maximum Forward Power Dissipation





LittleDiode supplies new, hard to find or obsolete electronic components and semiconductors all over the world.

With over two million different components listed you are sure to find the part you need.

Feel free to visit us today at our online store:

LittleDiode.com

Looking forward to providing you with the best possible service.