

- 1N5819UR-1 AND 1N6761UR-1 AVAILABLE IN JAN, JANTX, JANTXV AND JANS PER MIL-PRF-19500/586
- 1 AMP SCHOTTKY BARRIER RECTIFIERS
- HERMETICALLY SEALED
- LEADLESS PACKAGE FOR SURFACE MOUNT
- METALLURGICALLY BONDED

1N5819UR
and
CDLL5817 thru CDLL5819
and
CDLL6759 thru CDLL6761
and
CDLL1A20 thru CDLL1A100

MAXIMUM RATINGS

Operating Temperature: -55°C to +125°C
Storage Temperature: -55°C to +150°C
Average Rectified Forward Current: 1.0 AMP @ $T_{EC} = +55^{\circ}C$
Derating: 14 mA / °C above $T_{EC} = +55^{\circ}C$

ELECTRICAL CHARACTERISTICS @ 25°C, unless otherwise specified.

CDI TYPE NUMBER	WORKING PEAK REVERSE VOLTAGE	MAXIMUM FORWARD VOLTAGE			MAXIMUM REVERSE LEAKAGE CURRENT AT RATED VOLTAGE	
	V_{RWM}	$V_F @ 0.1A$	$V_F @ 1.0A$	$V_F @ 3.1A$	$I_R @ +25^{\circ}C$	$I_R @ +100^{\circ}C$
	VOLTS	VOLTS	VOLTS	VOLTS	mA	mA
CDLL5817	20	0.36	0.60	0.9	0.1	5.0
CDLL5818	30	0.36	0.60	0.9	0.1	5.0
CDLL5819	40	0.36	0.60	0.9	0.1	5.0
J,JX,JV & JS 5819UR-1	45	0.34	0.49	0.8	0.05	5.0
CDLL6759	60	0.38	0.69	N/A	0.1	6.0
CDLL6760	80	0.38	0.69	N/A	0.1	6.0
CDLL6761	100	0.38	0.69	N/A	0.1	6.0
J,JX,JV & JS 6761UR-1	100	0.38	0.69	N/A	0.10	12.0
CDLL1A20	20	0.36	0.60	0.9	0.1	5.0
CDLL1A30	30	0.36	0.60	0.9	0.1	5.0
CDLL1A40	40	0.36	0.60	0.9	0.1	5.0
CDLL1A50	50	0.36	0.60	0.9	0.1	5.0
CDLL1A60	60	0.38	0.69	N/A	0.1	12.0
CDLL1A80	80	0.38	0.69	N/A	0.1	12.0
CDLL1A100	100	0.38	0.69	N/A	0.1	12.0

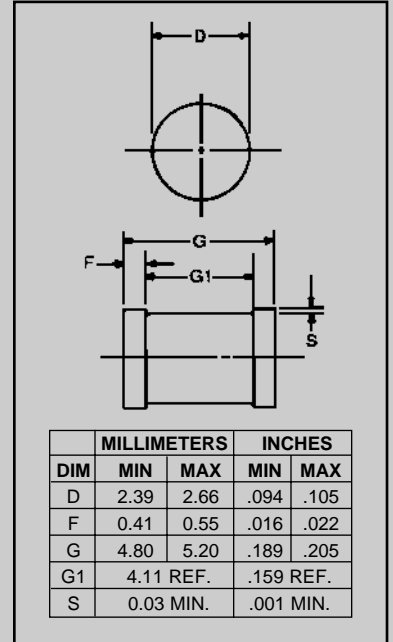

FIGURE 1

DESIGN DATA

CASE: DO-213AB, Hermetically sealed glass case. (MELF, LL41)

LEAD FINISH: Tin / Lead

THERMAL RESISTANCE: ($R_{\theta JC}$): 40 $\mu C/W$ maximum at L = 0 inch

THERMAL IMPEDANCE: ($Z_{\theta JX}$): 12 $\mu C/W$ maximum

POLARITY: Cathode end is banded.

MOUNTING SURFACE SELECTION:
The Axial Coefficient of Expansion (COE) Of this Device is Approximately +6PPM/°C. The COE of the Mounting Surface System Should Be Selected To Provide A Suitable Match With This Device.



CDLL5817 thru CDLL5819 and CDLL6759 thru CDLL6761 and CDLL1A20 thru CDLL1A100

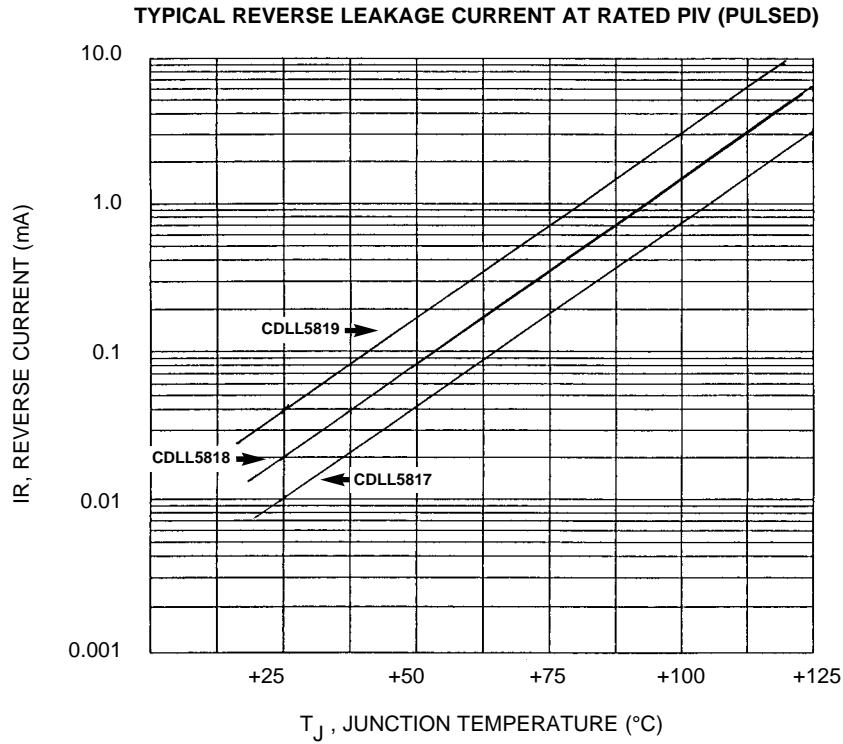

FIGURE 1

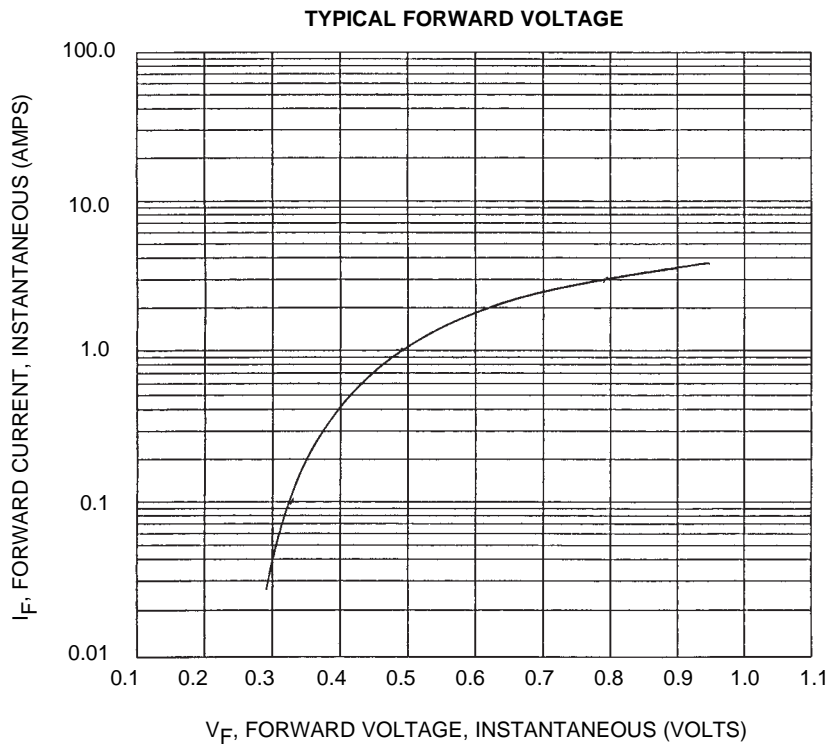

FIGURE 2



LittleDiode supplies new, hard to find or obsolete electronic components and semiconductors all over the world.

With over two million different components listed you are sure to find the part you need.

Feel free to visit us today at our online store:

LittleDiode.com

Looking forward to providing you with the best possible service.