

# Silicon Power Rectifier

## 1N1183–1N1190, 1N3765–1N3768

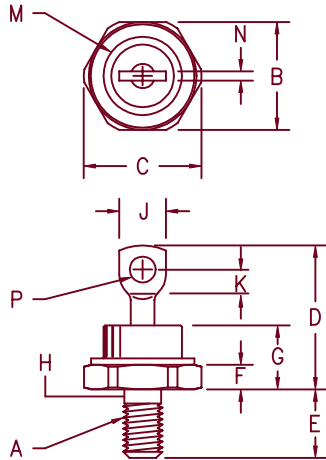

- Notes:
1. Full threads within 2 1/2 threads
  2. Standard Polarity: Stud is Cathode  
Reverse Polarity: Stud is Anode

Dim.	Inches		Millimeter		Notes
	Minimum	Maximum	Minimum	Maximum	
A	---	---	---	---	1/4–28
B	.667	.687	16.95	17.44	
C	---	.793	---	20.14	
D	---	1.00	---	25.40	
E	.422	.453	10.72	11.50	
F	.115	.200	2.92	5.08	
G	---	.450	---	11.43	
H	.220	.249	5.59	6.32	1
J	.250	.375	6.35	9.52	
K	.156	---	3.97	---	
M	---	.667	---	16.94	Dia
N	---	.080	---	2.03	
P	.140	.175	3.56	4.44	Dia

### DO203AB (DO–5)

JEDEC Numbers	Peak Reverse Voltage
1N1183, 1N1183A	50V
1N1184, 1N1184A	100V
1N1185, 1N1185A	150V
1N1186, 1N1186A	200V
1N1187, 1N1187A	300V
1N1188, 1N1188A	400V
1N1189, 1N1189A	500V
1N1190, 1N1190A	600V
1N3765	700V
1N3766	800V
1N3767	900V
1N3768	1000V

For Reverse Polarity add R to Part Number

- Glass Passivated Die
- 800A surge rating
- Glass to metal construction
- $V_{RRM}$  to 1000V

#### Electrical Characteristics

Average forward current	$I_F(AV)$ 40 Amps	$T_C = 146^\circ C$ , half sine wave, $R_{\theta JC} = 1.25^\circ C/W$
Maximum surge current	$I_{FSM}$ 800 Amps	8.3ms, half sine, $T_J = 200^\circ C$
Max $I^2 t$ for fusing	$I^2 t$ 2600 A <sup>2</sup> s	
Max peak forward voltage	$V_{FM}$ 1.19 Volts	$I_{FM} = 90A; T_J = 25^\circ C^*$
Max peak reverse current	$I_{RM}$ 10 $\mu A$	$V_{RRM}, T_J = 25^\circ C$
Max peak reverse current	$I_{RM}$ 2.0 mA	$V_{RRM}, T_J = 150^\circ C$
Max Recommended Operating Frequency	10kHz	

\*Pulse test: Pulse width 300  $\mu sec$ . Duty cycle 2%

#### Thermal and Mechanical Characteristics

Storage temperature range	$T_{STG}$	$-65^\circ C$ to $200^\circ C$
Operating junction temp range	$T_J$	$-65^\circ C$ to $200^\circ C$
Maximum thermal resistance	$R_{\theta JC}$	1.25 $^\circ C/W$ Junction to Case
Mounting torque		25–30 inch pounds
Weight		.5 ounces (14 grams) typical

9–3–03 Rev. 1

# 1N1183-1N1190, 1N3765-1N3768

Figure 1  
Typical Forward Characteristics

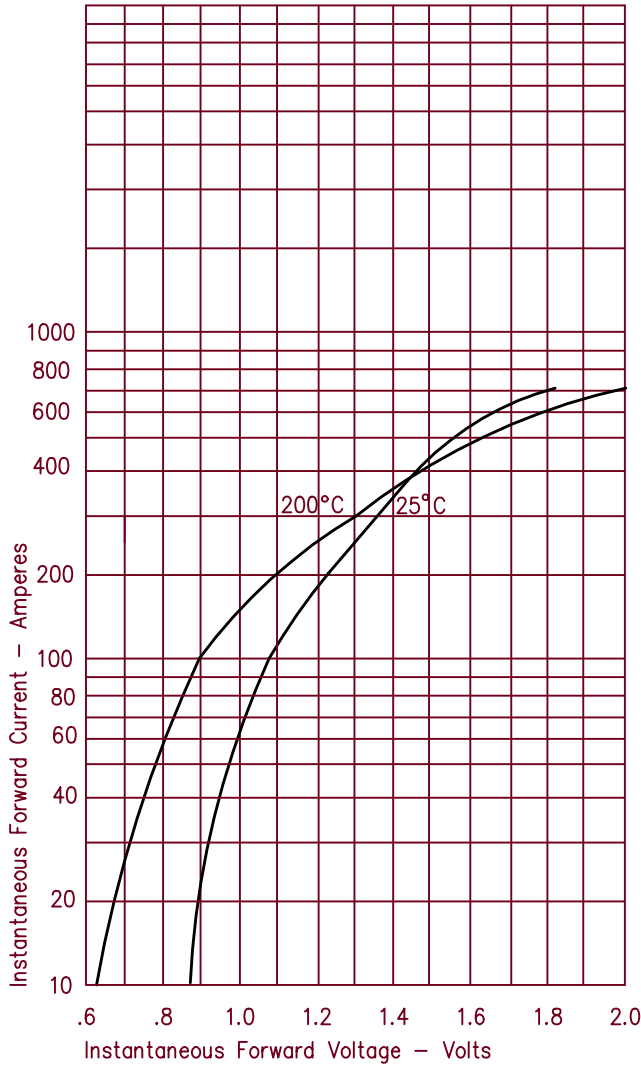

Figure 3  
Forward Current Derating

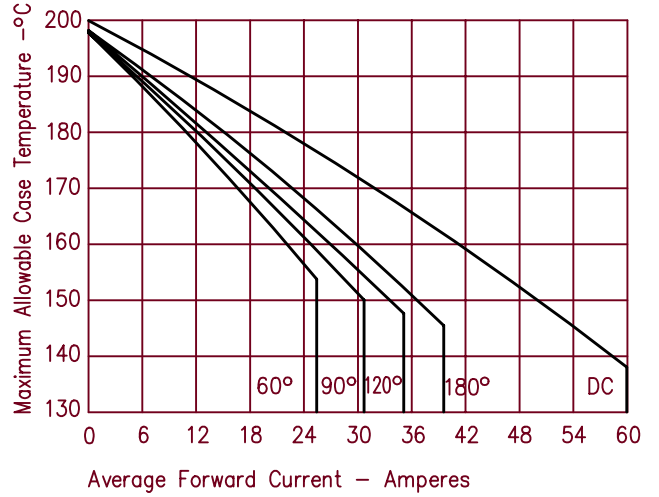

Figure 4  
Maximum Forward Power Dissipation

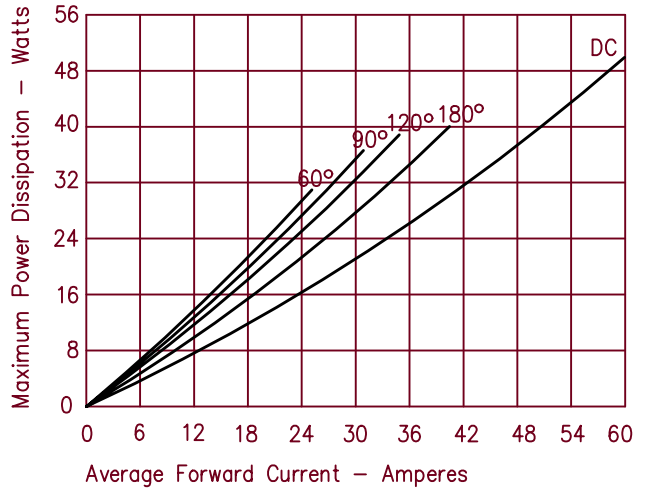

Figure 2  
Typical Reverse Characteristics

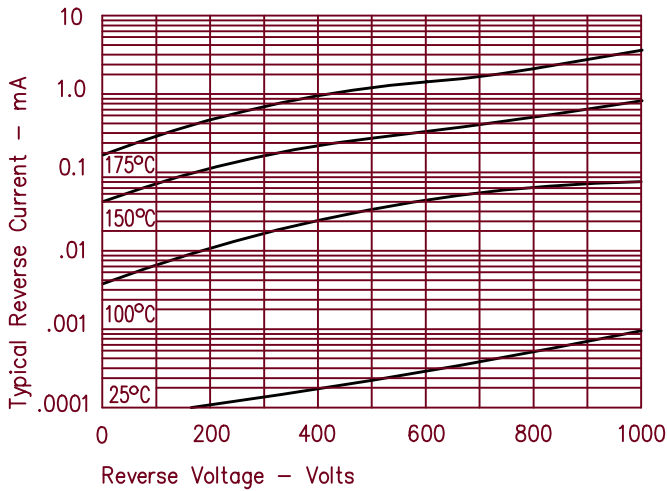
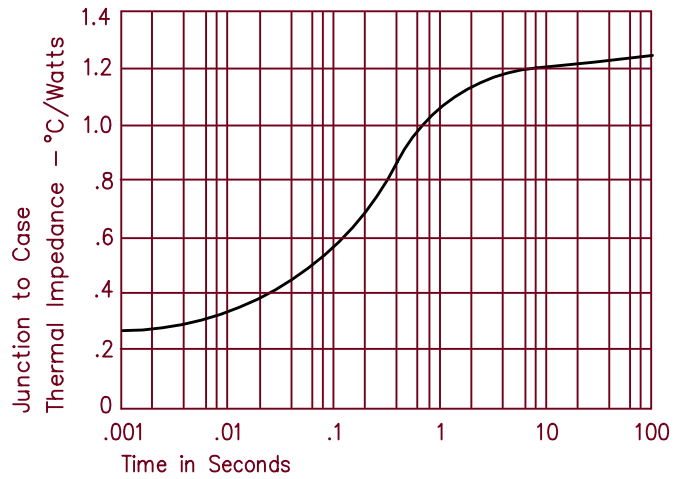

Figure 5  
Transient Thermal Impedance





LittleDiode supplies new, hard to find or obsolete electronic components and semiconductors all over the world.

With over two million different components listed you are sure to find the part you need.

Feel free to visit us today at our online store:

**[LittleDiode.com](http://LittleDiode.com)**

Looking forward to providing you with the best possible service.