

Schottky Power Surface Mount FST81SM1–SM6 Series

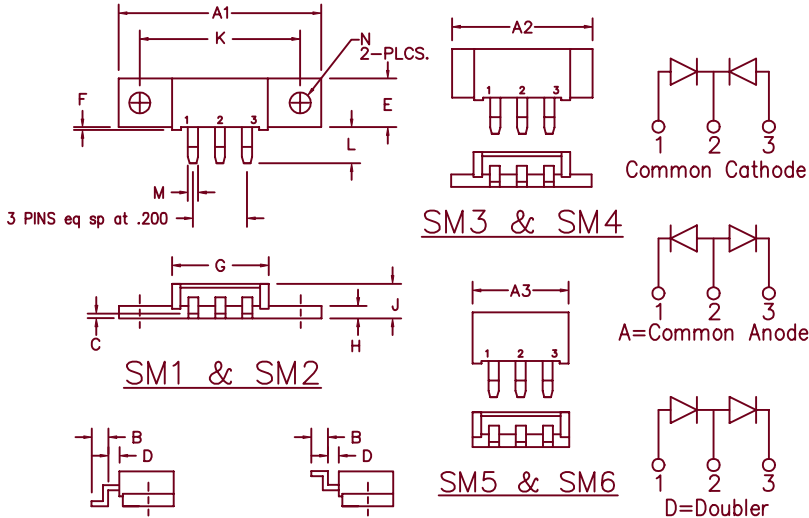

TYP. PIN CONFIGURATION FOR SM1, SM3, & SM5
TYP. PIN CONFIGURATION FOR SM2, SM4, & SM6

Note: Baseplate Common with Pin 2

Dim.	Inches		Millimeter		Notes
	Minimum	Maximum	Minimum	Maximum	
A1	1.490	1.510	37.85	38.35	
A2	1.020	1.040	26.12	26.42	
A3	.695	.715	17.65	18.16	
B	.110	.120	2.79	3.04	
C	.027	.037	0.69	0.94	
D	.100	.110	2.54	2.79	
E	.350	.370	8.89	9.40	
F	.015	.025	0.38	0.64	
G	.695	.715	17.65	18.16	
H	.088	.098	2.24	2.49	
J	.240	.260	6.10	6.60	
K	1.180	1.195	29.97	30.35	
L	.230	.250	5.84	6.35	
M	.065	.085	1.65	2.16	
N	.151	.161	3.84	4.09	Dia.

Microsemi Catalog Catalog Number	Industry Part Number	Working Peak Reverse Voltage	Repetitive Peak Reverse Voltage
FST8135SM ^{①②}	80CNQ035ASL 80CNQ035ASM	35V	35V
FST8140SM --	80CNQ040ASL 80CNQ040ASM	40V	40V
FST8145SM --	80CNQ045ASL 80CNQ045ASM	45V	45V

Note: ① Specify (1–6) to identify package desired
② Specify C–Common Cathode, A–Common Anode, D–Doubler

- Schottky Barrier Rectifier
- Guard Ring Protection
- Common Cathode Center Tap
- Low Forward Voltage
- 2 X 40 Amperes Avg.
- 150°C Junction Temperature
- Reverse Energy Tested

Electrical Characteristics

Average forward current per pkg	I _{F(AV)} 80 Amps	T _C = 110°C, Square wave, R _{θJC} = 0.5°C/W
Average forward current per leg	I _{F(AV)} 40 Amps	T _C = 110°C, Square wave, R _{θJC} = 1.0°C/W
Maximum surge current per leg	I _{FSM} 800 Amps	8.3 ms, half sine, T _J = 150°C
Max repetitive peak reverse current per leg	I _{R(OV)} 2 Amps	f = 1 KHZ, 25°C, 1 usec square wave
Max peak forward voltage per leg	V _{FM} 0.47 volts	I _{FM} = 40A: T _J = 150°C*
Max peak forward voltage per leg	V _{FM} 0.53 volts	I _{FM} = 40A: T _J = 25°C*
Max peak reverse current per leg	I _{RM} 500 mA	V _{RRM} , T _C = 125°C*
Max peak reverse current per leg	I _{RM} 3.0 mA	V _{RRM} , T _J = 25°C
Typical junction capacitance per leg	C _J 2100 pF	V _R = 5.0V, T _C = 25°C

*Pulse test: Pulse width 300 usec, Duty cycle 2%

Thermal and Mechanical Characteristics

Storage temp range	T _{STG}	-55°C to 175°C
Operating junction temp range	T _J	-55°C to 150°C
Max thermal resistance per leg	R _{θJC}	1.0°C/W Junction to case
Max thermal resistance per pkg.	R _{θJC}	0.5°C/W Junction to case
Typical thermal resistance (greased)	R _{θCS}	0.3°C/W Case to sink
Mounting Base Torque		10 inch pounds maximum (SM1, 2)
Weight		SM1–2 0.3 ounce (8.4 grams) typical SM3–4 0.24 ounce (6.7 grams) typical SM5–6 0.18 ounce (5.2 grams) typical

FST81SM1 — SM6

Figure 1
Typical Forward Characteristics — Per Leg

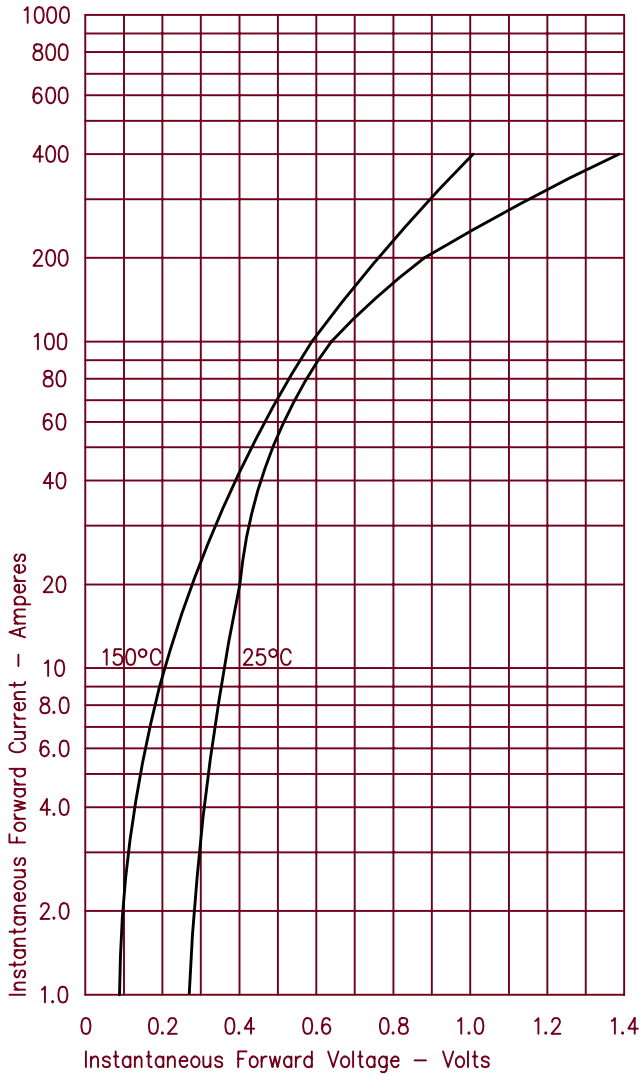

Figure 3
Typical Junction Capacitance — Per Leg

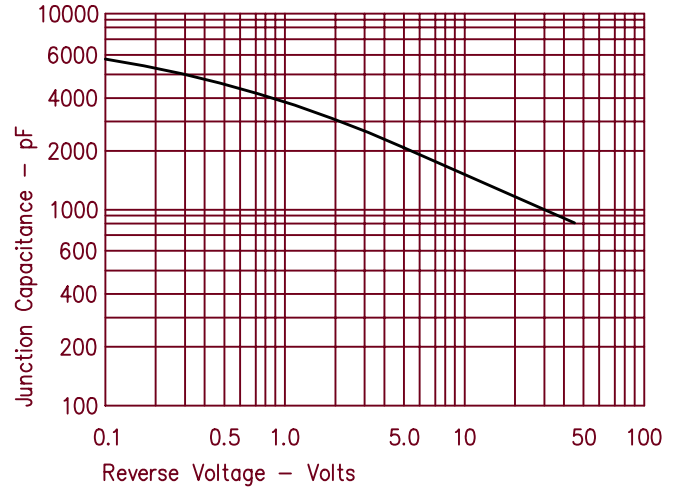

Figure 4
Forward Current Derating — Per Leg

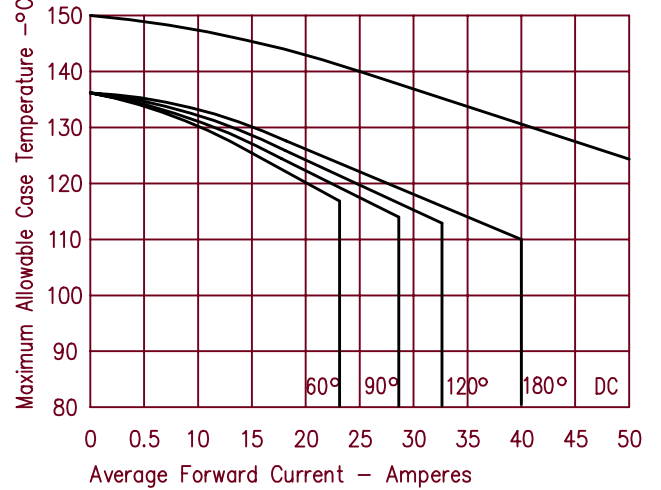

Figure 2
Typical Reverse Characteristics — Per Leg

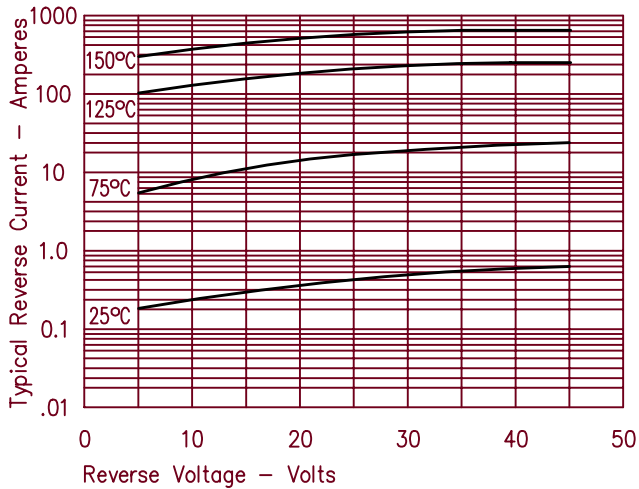
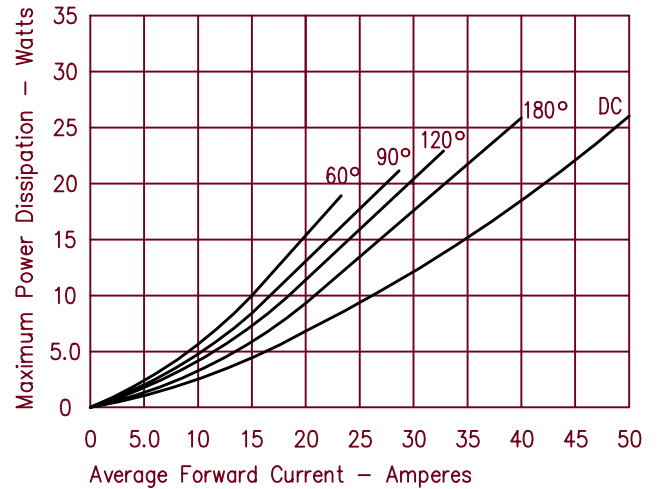

Figure 5
Maximum Forward Power Dissipation — Per Leg





LittleDiode supplies new, hard to find or obsolete electronic components and semiconductors all over the world.

With over two million different components listed you are sure to find the part you need.

Feel free to visit us today at our online store:

LittleDiode.com

Looking forward to providing you with the best possible service.