

64-Channel Serial To Parallel Converter With High Voltage Push-Pull Outputs

Ordering Information

Device	Recommended Operating V_{PP} Max	Package Options		
		80-Lead Quad Cerpak Gullwing	80-Lead Quad Plastic Gullwing	Die
HV3418	180V	HV3418DG	HV3418PG	HV3418X

Features

- HVCMOS® technology
- Output voltages up to 180V
- Low power level shifting
- Shift register speed: 6MHz @ $V_{DD} = 5V$
12MHz @ $V_{DD} = 12V$
- Latched data outputs
- Output polarity and blanking
- CMOS compatible inputs
- Forward and reverse shifting options

General Description

The HV34 is a low voltage serial to high voltage parallel converter with push-pull outputs. This device has been designed for use as a printer driver for inkjet applications. It can also be used in any application requiring multiple output high voltage, low current sourcing and sinking capabilities.

The device consists of a 64-bit shift register, 64 latches, and control logic to perform the polarity select and blanking of the outputs. A DIR pin controls the direction of data shift through the device. With DIR grounded, D_{IOA} is Data-In and D_{IOB} is Data-Out; data is shifted from HV_{OUT64} to HV_{OUT1} . When DIR is at logic high, D_{IOB} is Data-In and D_{IOA} is Data-Out; data is then shifted from HV_{OUT1} to HV_{OUT64} . Data is shifted through the shift register on the low to high transition of the clock. Data output buffers are provided for cascading devices. Operation of the shift register is not affected by the \overline{LE} (latch enable), \overline{BL} (blinking), or the \overline{POL} (polarity) inputs. Transfer of data from the shift register to the latch occurs when the \overline{LE} (latch enable) is high. The data in the latch is stored during \overline{LE} transition from high to low.

Absolute Maximum Ratings¹

Supply voltage, V_{DD}	-0.5V to +15V	
Supply voltage, V_{PP}	V_{DD} to +200V	
Logic input levels	-0.5V to $V_{DD} + 0.5V$	
Ground current ²	1.5A	
High voltage supply current ²	1.3A	
Continuous total power dissipation ³	Ceramic	1900mW
	Plastic	1200mW
Operating temperature range	Ceramic	-55°C to +125°C
	Plastic	-40°C to +85°C
Storage temperature range	-65°C to +150°C	

Notes:

1. All voltages are referenced to GND.
2. Connection to all power and ground pads is required. Duty cycle is limited by the total power dissipated in the package.
3. For operation above 25°C ambient derate linearly to maximum operating temperature at 20mW/°C for plastic and at 31.7mW/°C for ceramic.

Electrical Characteristics (over recommended operating conditions unless noted)

DC Characteristics

Symbol	Parameter		Min	Typ	Max	Units	Conditions
I_{DD}	V_{DD} Supply Current				25	mA	$f_{CLK} = 12\text{MHz}$, $f_{DATA} = 12\text{MHz}$ $\overline{LE} = \text{LOW}$
I_{DDQ}	Quiescent V_{DD} Supply Current				200	μA	All $V_{IN} = 0\text{V}$ or V_{DD}
I_{PP}	High Voltage Supply Current				0.50	mA	$V_{PP} = 180\text{V}$ All outputs high
					0.50	mA	$V_{PP} = 180\text{V}$ All outputs low
I_{IH}	High-Level Logic Input Current				10	μA	$V_{IH} = V_{DD}$
I_{IL}	Low-Level Logic Input Current				-10	μA	$V_{IL} = 0\text{V}$
V_{OH}	High-Level Output	HV _{OUT}	155			V	$V_{PP} = 180\text{V}$, $I_{HV_{OUT}} = -5\text{mA}$ $I_{D_{OUT}} = -100\mu\text{A}$
		Data Out	$V_{DD} - 1\text{V}$			V	
V_{OL}	Low-Level Output	HV _{OUT}			25	V	$V_{PP} = 180\text{V}$, $I_{HV_{OUT}} = +5\text{mA}$ $I_{D_{OUT}} = +100\mu\text{A}$
		Data Out			1.0	V	
V_{OC}	HV _{OUT} Clamp Voltage				$V_{PP} + 1.5$	V	$I_{OL} = +5\text{mA}$
					-1.5	V	$I_{OL} = -5\text{mA}$

AC Characteristics^{1,2} (For $V_{DD} = 12\text{V}$: values in parentheses are for $V_{DD} = 5\text{V}$; $V_{PP} = 180\text{V}$, $T_A = 25^\circ\text{C}$)

Symbol	Parameter		Min	Typ	Max	Units	Conditions
f_{CLK}	Clock Frequency				12(6)	MHz	
t_W	Clock Width High and Low	High	40(83)			ns	
t_{SU}	Data Setup Time Before Clock Rises		25(35)			ns	
t_H	Data Hold Time After Clock Rises		10(30)			ns	
t_{WLE}	Width of Latch Enable Pulse		62(80)			ns	
t_{DLE}	\overline{LE} Delay Time Rising Edge of Clock		25(35)			ns	
t_{SLE}	\overline{LE} Setup Time Before Rising Edge of Clock		30(40)			ns	
t_{ON}, t_{OFF}	Time from Latch Enable to HV _{OUT}				1(1.5)	μs	$C_L = 20\text{pF}$
t_{DHL}	Delay Time Clock to Data High to Low				50(110)	ns	$C_L = 20\text{pF}$
t_{DLH}	Delay Time Clock to Data Low to High				75(160)	ns	$C_L = 20\text{pF}$
t_r, t_f	All Logic Inputs				5	ns	

Notes:

- Shift register speed can be as low as DC as long as Data Set-up and Hold Time meet the spec.
- AC Characteristics are guaranteed only under $V_{DD} = 12\text{V}$ and $V_{DD} = 5\text{V}$.

Recommended Operating Conditions

Symbol	Parameter		Min	Typ	Max	Units
V_{DD}	Logic supply voltage	$V_{DD} = 5\text{V}$	4.5	5.0	5.5	V
		$V_{DD} = 12\text{V}$	10.8	12.0	13.2	V
V_{PP}	High voltage supply		60		180	V
V_{IH}	High-level input voltage		$V_{DD} - 0.9$		V_{DD}	V
V_{IL}	Low-level input voltage		0		0.9	V
T_A	Operating free-air temperature	Plastic	-40		+85	$^\circ\text{C}$
		Ceramic	-55		+125	

Notes:

Power-up sequence should be the following:

- Connect ground.
- Apply V_{DD} .
- Set all inputs (Data, CLK, Enable, etc.) to a known state.
- Apply V_{PP} .
- The V_{PP} should not drop below V_{DD} or float during operation.

Power-down sequence should be the reverse of the above.

Input and Output Equivalent Circuits

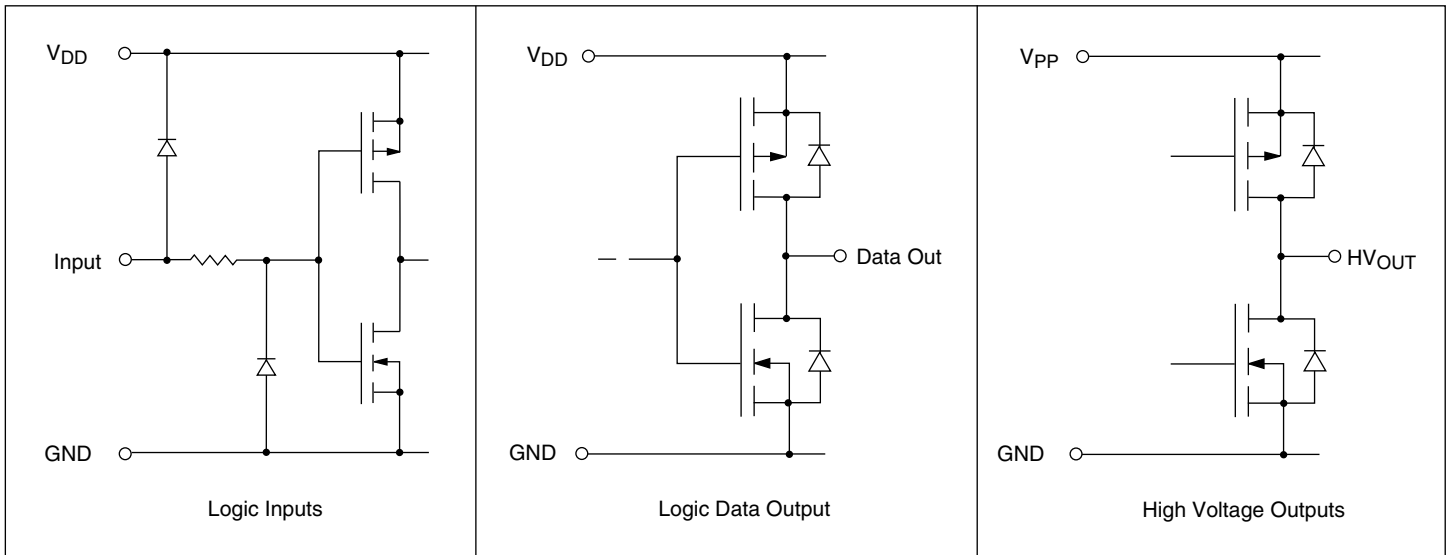

Switching Waveforms

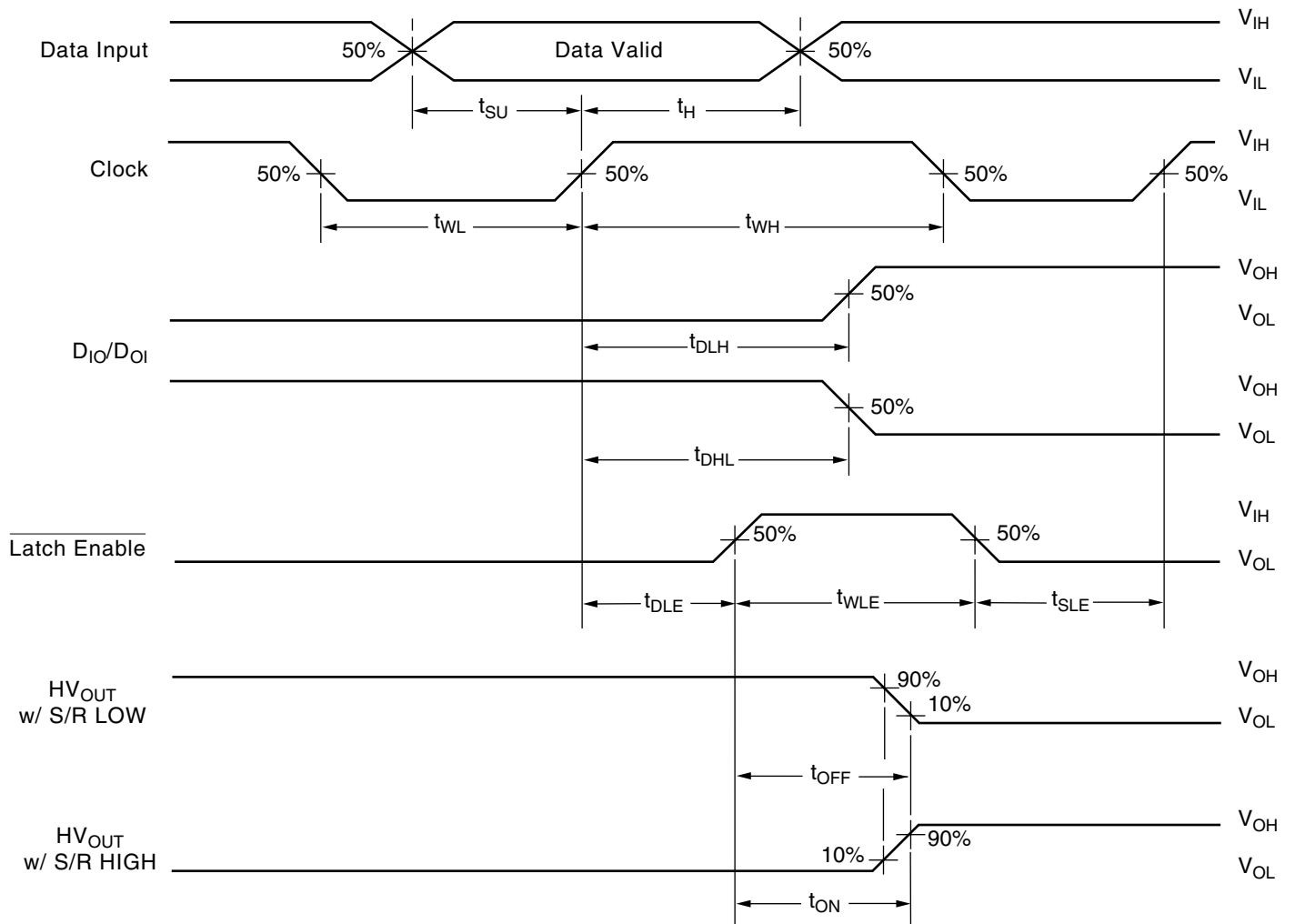

Functional Block Diagram

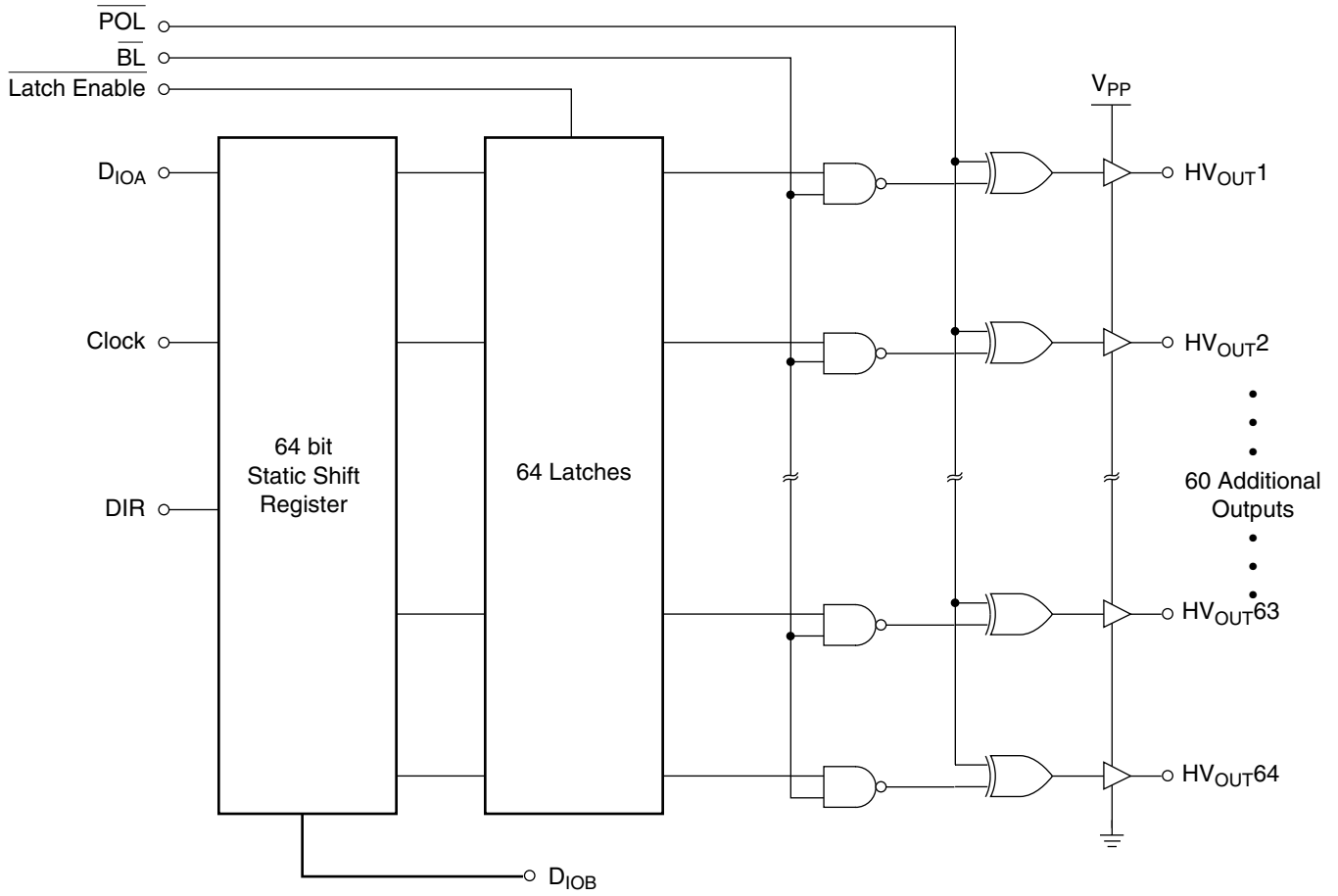

Function Table

Function	Inputs						Outputs				
	Data	CLK	\overline{LE}	\overline{BL}	\overline{POL}	DIR	Shift Reg 1 2...64	HV Outputs 1 2...64		Data Out *	
All on	X	X	X	L	L	X	* *...*	H	H...H	*	
All off	X	X	X	L	H	X	* *...*	L	L...L	*	
Invert mode	X	X	L	H	L	X	* *...*	$\overline{*}$	$\overline{*...*}$	*	
Load S/R	H or L	↑	L	H	H	X	H or L *...*	*	*...*	*	
Load/Store Data in Latches	X	X	↓	H	H	X	* *...*	*	*...*	*	
	X	X	↓	H	L	X	* *...*	$\overline{*}$	$\overline{*...*}$	*	
Transparent Latch mode	L	↑	H	H	H	X	L *...*	L	*...*	*	
	H	↑	H	H	H	X	H *...*	H	*...*	*	
I/O Relation	D _{IOA}	↑	X	X	X	L	Q _n → Q _{n-1}	—	—	D _{IOB}	
	D _{IOB}	↑	X	X	X	H	Q _n → Q _{n+1}	—	—	D _{IOA}	

Notes:
 H = high level, L = low level, X = irrelevant, ↑ = low-to-high transition, ↓ = high-to-low transition.
 * = dependent on previous stage's state before the last CLK or last \overline{LE} high.

Pin Configurations

HV34

Pin	Function	Pin	Function
1	HV _{OUT} 41/24	41	HV _{OUT} 1/64
2	HV _{OUT} 42/23	42	HV _{OUT} 2/63
3	HV _{OUT} 43/22	43	HV _{OUT} 3/62
4	HV _{OUT} 44/21	44	HV _{OUT} 4/61
5	HV _{OUT} 45/20	45	HV _{OUT} 5/60
6	HV _{OUT} 46/19	46	HV _{OUT} 6/59
7	HV _{OUT} 47/18	47	HV _{OUT} 7/58
8	HV _{OUT} 48/17	48	HV _{OUT} 8/57
9	HV _{OUT} 49/16	49	HV _{OUT} 9/56
10	HV _{OUT} 50/15	50	HV _{OUT} 10/55
11	HV _{OUT} 51/14	51	HV _{OUT} 11/54
12	HV _{OUT} 52/13	52	HV _{OUT} 12/53
13	HV _{OUT} 53/12	53	HV _{OUT} 13/52
14	HV _{OUT} 54/11	54	HV _{OUT} 14/51
15	HV _{OUT} 55/10	55	HV _{OUT} 15/50
16	HV _{OUT} 56/9	56	HV _{OUT} 16/49
17	HV _{OUT} 57/8	57	HV _{OUT} 17/48
18	HV _{OUT} 58/7	58	HV _{OUT} 18/47
19	HV _{OUT} 59/6	59	HV _{OUT} 19/46
20	HV _{OUT} 60/5	60	HV _{OUT} 20/45
21	HV _{OUT} 61/4	61	HV _{OUT} 21/44
22	HV _{OUT} 62/3	62	HV _{OUT} 22/43
23	HV _{OUT} 63/2	63	HV _{OUT} 23/42
24	HV _{OUT} 64/1	64	HV _{OUT} 24/41
25	V _{PP}	65	HV _{OUT} 25/40
26	D _{IOA}	66	HV _{OUT} 26/39
27	N/C	67	HV _{OUT} 27/38
28	N/C	68	HV _{OUT} 28/37
29	$\overline{\text{BL}}$	69	HV _{OUT} 29/36
30	$\overline{\text{POL}}$	70	HV _{OUT} 30/35
31	V _{DD}	71	HV _{OUT} 31/34
32	DIR	72	HV _{OUT} 32/33
33	LGND	73	HV _{OUT} 33/32
34	OGND	74	HV _{OUT} 34/31
35	N/C	75	HV _{OUT} 35/30
36	N/C	76	HV _{OUT} 36/29
37	CLK	77	HV _{OUT} 37/28
38	$\overline{\text{LE}}$	78	HV _{OUT} 38/27
39	D _{IOB}	79	HV _{OUT} 39/26
40	V _{PP}	80	HV _{OUT} 40/25

Package Outline

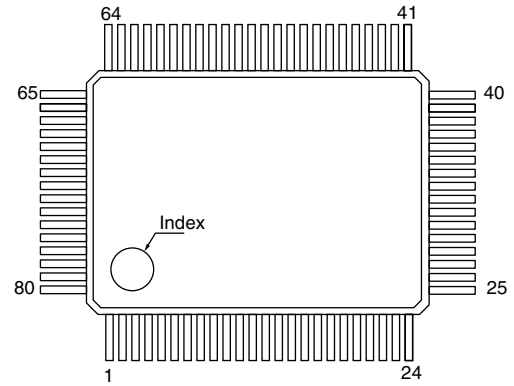

top view

80-pin Gullwing Package

Note:

Pin designation for DIR = H/L

Example: for DIR = H, Pin 1 is HV_{OUT}41
for DIR = L, Pin 1 is HV_{OUT}24



LittleDiode supplies new, hard to find or obsolete electronic components and semiconductors all over the world.

With over two million different components listed you are sure to find the part you need.

Feel free to visit us today at our online store:

LittleDiode.com

Looking forward to providing you with the best possible service.