

FEATURES

Companion to High Resolution A/D Converters
Fast Acquisition Time: $2.5\mu\text{s}$ to $\pm 0.003\%$
Low Droop Rate: $0.1\mu\text{V}/\mu\text{s}$
Aperture Jitter: 400ps
Internal Hold Capacitor
Unity Gain Inverter
Low Power Dissipation: 300mW

PRODUCT DESCRIPTION

The AD389 is a high accuracy, adjustment free track-and-hold amplifier designed for high resolution data acquisition applications. The fast acquisition time ($2.5\mu\text{s}$ to $300\mu\text{V}$) and low aperture jitter (400ps) make it suitable for use with fast A/D converters to digitize signals up to 40kHz.

The AD389 is complete with an internal hold capacitor and it incorporates a compensation network which minimizes the sample to hold charge offset.

Typical applications for the AD389 include sampled data systems, peak hold functions, strobed measurement systems and simultaneous sampling converter systems. When used with autozero and autocalibration techniques, this T/H combined with a high linearity A/D will offer 14-bit performance over the converter's full no-missing-code temperature range.

The device is available in two versions: the "K" specified for operation over the 0 to $+70^\circ\text{C}$ commercial temperature range and the "B" specified over the full industrial temperature range, -25°C to $+85^\circ\text{C}$. High reliability processing available; contact factory for information.

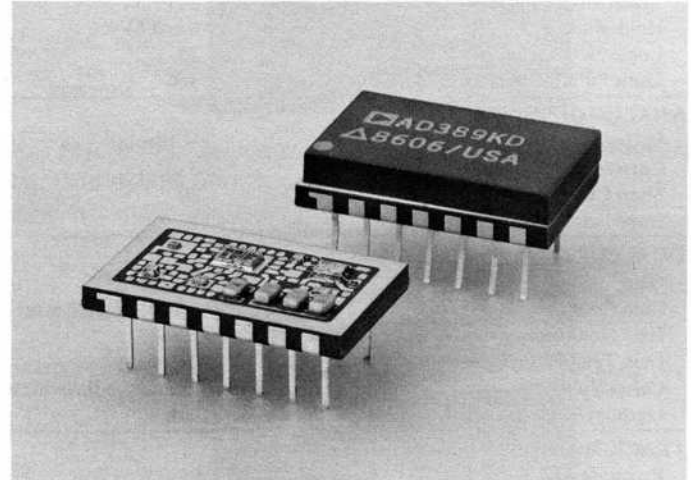
**PRODUCT HIGHLIGHTS**

1. The AD389 is the ideal companion track-and-hold amplifier to 14-bit accurate A/D converters.
2. The AD389 provides separate analog and digital grounds, thus improving the device's immunity to ground and switching transients.
3. The droop rate is only $0.1\mu\text{V}/\mu\text{s}$ so that it may be used in slower high resolution systems without the loss of accuracy.
4. The fast acquisition time and low aperture make it suitable for high speed data acquisition systems and digital audio recording.
5. The AD389 T/H amplifier is ideal for applications requiring wide dynamic range.
6. Clever circuit design eliminates any measurable thermal tail (see Figures 11a and 11b).

Information furnished by Analog Devices is believed to be accurate and reliable. However, no responsibility is assumed by Analog Devices for its use; nor for any infringements of patents or other rights of third parties which may result from its use. No license is granted by implication or otherwise under any patent or patent rights of Analog Devices.

Two Technology Way; Norwood, MA 02062-9106 U.S.A.
Tel: 617/329-4700 **Twx: 710/394-6577**
Telex: 174059 **Cables: ANALOG NORWOODMASS**

SPECIFICATIONS (typical @ +25°C and nominal power supply voltage of ±15V unless otherwise noted)

Model	AD389KD	AD389BD	UNITS
ANALOG INPUT			
Voltage Range	±10 min	*	V
Overshoot, no damage	±15 max	*	V
Impedance	3000	*	Ω
DIGITAL INPUT (TTL Compatible)			
Track Mode, Logic "1"	2 to 5.5V	*	V
Hold Mode, Logic "0"	0 to 0.8V	*	V
Logic "1" Current	20	*	μA
Logic "0" Current	360	*	μA
ANALOG OUTPUT			
Voltage	±10 min	*	V
Current	3	*	mA
Short Circuit Current	20	*	mA
Impedance	1	*	Ω
DC ACCURACY/STABILITY			
Gain	-1.00	*	V/V
Gain Error	±0.01 (±0.02 max)	*	%
Gain Nonlinearity (±10V Output Track)	±0.001	*	%
Gain Temperature Coefficient	1 (5 max)	*	ppm/°C
Offset Voltage	±3 max, adjustable to zero	*	mV
Output Offset @ T _{min} , T _{max} (Track)	±6	*	mV
TRACK MODE DYNAMICS			
Frequency Response			
Small Signal (-3dB)	1.5	*	MHz
Full Power Bandwidth	0.5	*	MHz
Slew Rate	30	*	V/μs
Noise in Track Mode, dc to 1.0MHz	200	*	μV rms
TRACK-TO-HOLD SWITCHING			
Aperture Time	30	*	ns
Aperture Uncertainty (Jitter)	0.4	*	ns
Offset Step (Pedestal)	±2 (4 max)	*	mV
Pedestal with Temperature	±4	±6	mV
Switching Transient			
Amplitude	200	*	mV
Settling to 1mV	0.5 (2 max)	*	μs
Settling to 0.3mV	1.0 (3 max)	*	μs
HOLD MODE DYNAMICS			
Droop Rate	0.1 (1 max)	*	μV/μs
Droop Rate at T _{max}	10 max	40 max	μV/μs
Feedthrough Rejection (10V p-p @ 20kHz)	86 (74 min)	*	dB
HOLD-TO-TRACK DYNAMICS			
Acquisition Time to ±0.01% of 20V	1.5 (3 max)	*	μs
Acquisition Time to ±0.003% of 20V	2.5 (5 max)	*	μs
POWER REQUIREMENTS			
Nominal Voltages for Rated Performance	±15 (±3%)	*	V
Operating Range ¹	±11 to ±18	*	V
Power Supply Rejection	100	*	μV/V
Supply Current			
+V _S	15 (20 max)	*	mA
-V _S	-4 (10 max)	*	mA
Power Dissipation	300 (500 max)	*	mW
TEMPERATURE RANGE			
Operating	0 to +70	-25 to +85	°C
Storage	-55 to +125	*	°C
THERMAL RESISTANCE			
Junction to Air, θ _{ja} (free air)	60	*	°C/W
Junction to Case, θ _{jc}	20	*	°C/W

NOTES

¹Operating to derated performance with $|V_{IN}| < |V_S - 5V|$.

*Specifications same as AD389KD.

Specifications subject to change without notice.

OUTLINE DIMENSIONS

Dimensions shown in inches and (mm).

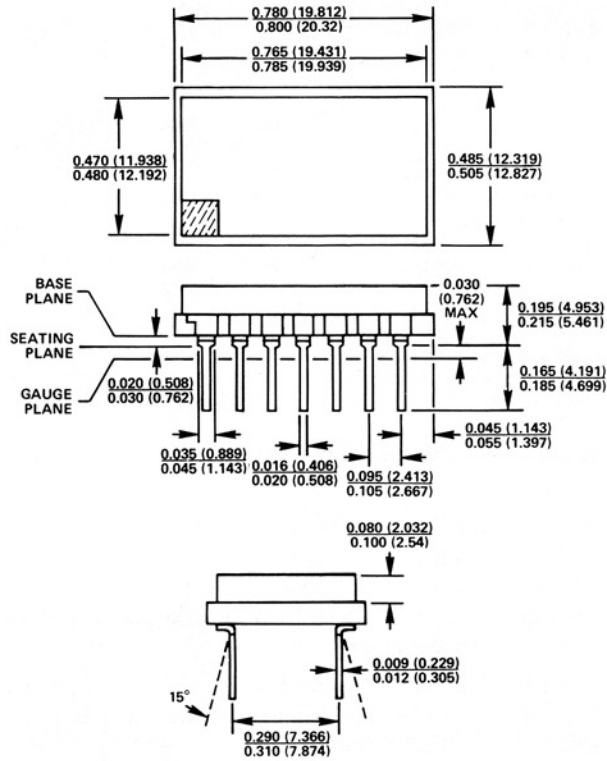

FUNCTIONAL BLOCK DIAGRAM

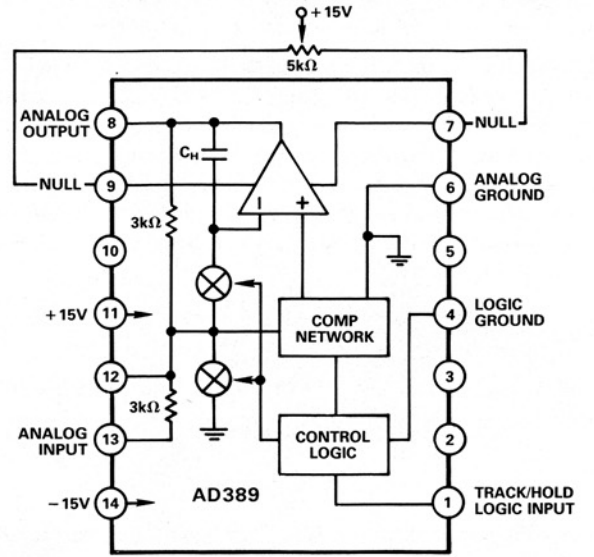

ORDERING GUIDE

Model	Temperature Range
AD389KD	0 to +70°C
AD389BD	-25°C to +85°C

PIN CONFIGURATION

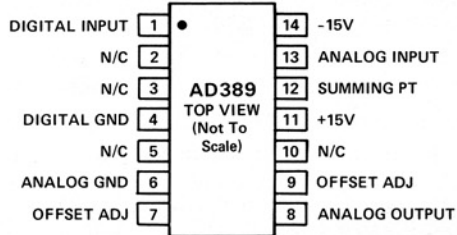

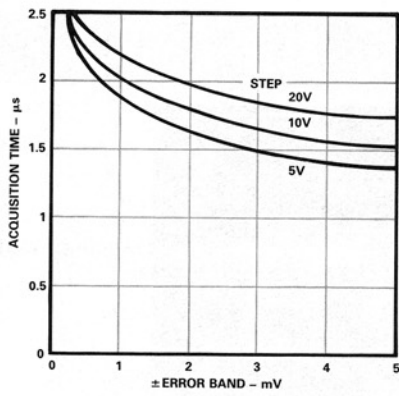

Figure 1. Acquisition Time vs. Final Error Band

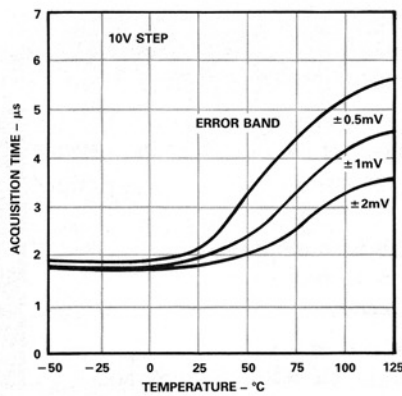

Figure 2. Acquisition Time vs. Temperature

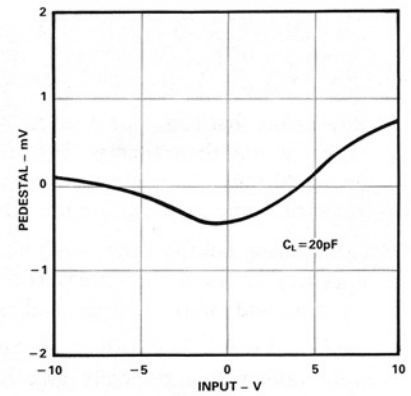

Figure 3. Pedestal vs. Input Voltage

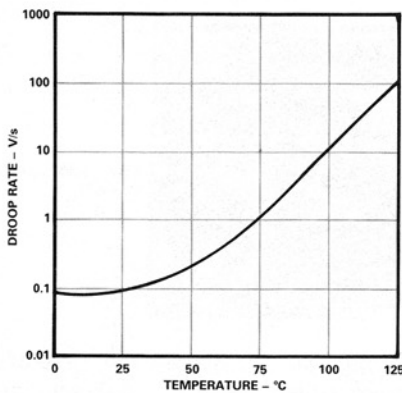

Figure 4. Droop Rate vs. Temperature

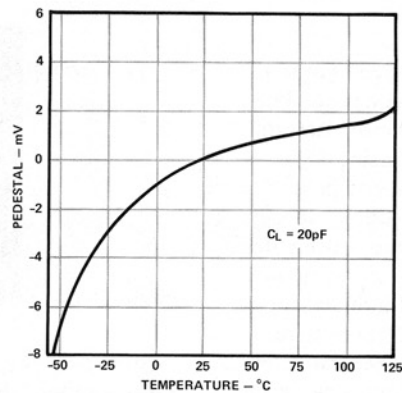

Figure 5. Pedestal vs. Temperature

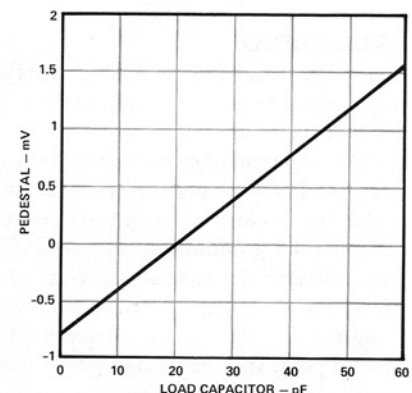

Figure 6. Pedestal vs. Load Capacitor

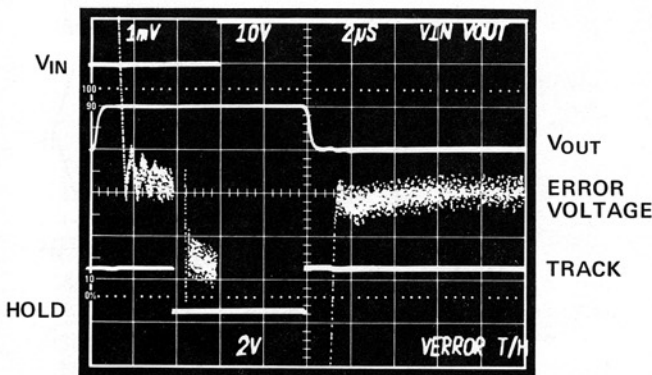

Figure 7. Hold to Track Acquisition Time

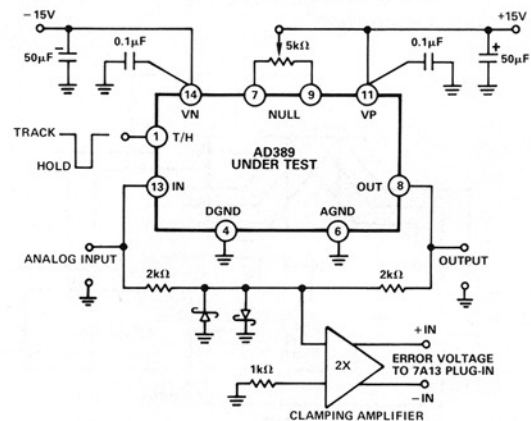

Figure 8. Pedestal and Acquisition Time Test Circuit

TERMINOLOGY

Aperture Time is the time required after the “hold” command until the switch is fully open and it produces a delay in the effective sampling timing.

Aperture Jitter is the uncertainty in Aperture Time. If the Aperture Time is “tuned out” by advancing the track-to-hold command with respect to the input signal, the Aperture Jitter now determines the maximum sampling frequency.

Acquisition Time is the time required by the device to reach its final value within a given error band after the track command has been given. This includes switch delay time, slewing time and settling time for a given output voltage change.

Droop is the change in the output voltage from the “held” value as a result of device leakage.

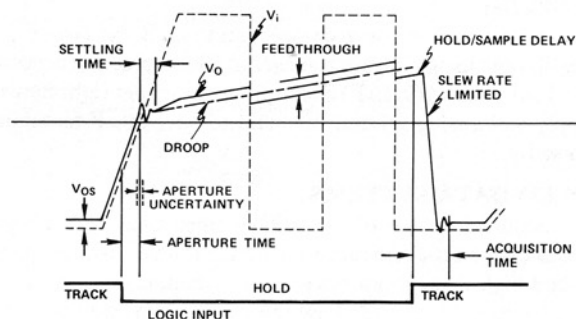

Figure 9. Pictorial Showing Various T/H Characteristics

Feedthrough is that component of the output which follows the input signal *after* the switch is open. As a percentage of the input, feedthrough is determined as the ratio of the feedthrough capacitance to the hold capacitance (C_F/C_H).

Pedestal during hold is a track-to-hold offset. This is an offset that occurs from such phenomena as charge dumps when switches are opened, and coupling of the logic signal transients.

Thermal Tail is the slow drift of the output stage as it settles to the final value with a thermally induced offset due to self-heating; see Figures 11a and 11b.

Transients are the spikes or glitches that occur on the output at the start and end of hold time.

GROUNDING

Many data-acquisition components have two or more ground pins which are not connected together within the device. These "grounds" are usually referred to as the Logic Power Return, Analog Common (Analog Power Return), and Analog Signal Ground. These grounds must be tied together at one point, preferably as close to the A-to-D converter as possible. Ideally, a single solid ground would be desirable. However, since current flows through the ground wires and etch stripes of the circuit cards, and since these paths have resistance and inductance, hundreds of millivolts can be generated between the system ground point and the ground pins of the AD389. Separate ground returns should be provided to minimize the current flow in the path from sensitive points to the system ground point. In this way supply currents and logic-gate return currents are not summed into the same return path as analog signals where they would cause measurement errors.

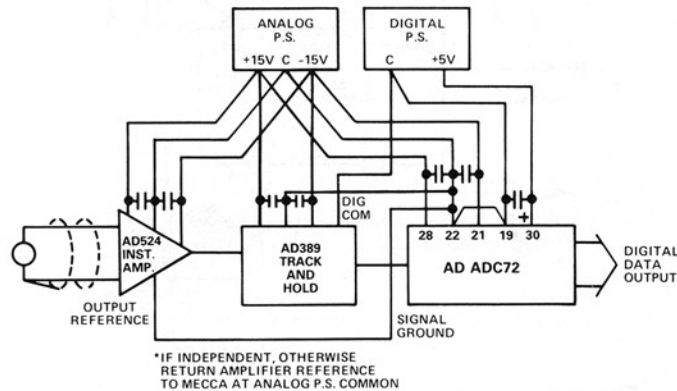

Figure 10. Basic Grounding and Decoupling Practice

DECOUPLING

The AD389 can only settle accurately and fast if the power supplies do not change during transients. Therefore, it is necessary to put 0.1 microfarad (0.1 μ F) decoupling capacitors right between the supply and analog ground pins and to have 50 μ F tantalum caps close by.

SAMPLED DATA SYSTEMS

The fast acquisition time of the AD389 when used with a high speed A/D converter allows accurate digitization of high frequency signals and high throughput rates in multichannel data acquisition systems. Figures 12 and 13 show the use of an AD389 with the ADC72 and AD376.

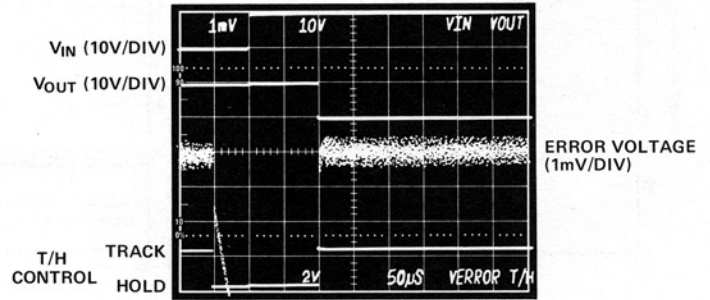

Figure 11a. Acquisition Time after 100 μ s in the Hold Mode. The AD389 Shows no "Thermal Tail".

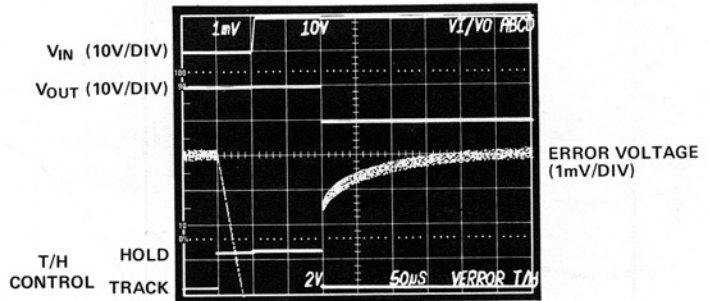

Figure 11b. Typical Thermal Tail and Acquisition Time of Other 12-Bit T/Hs Make them Unsuitable for High Resolution Applications

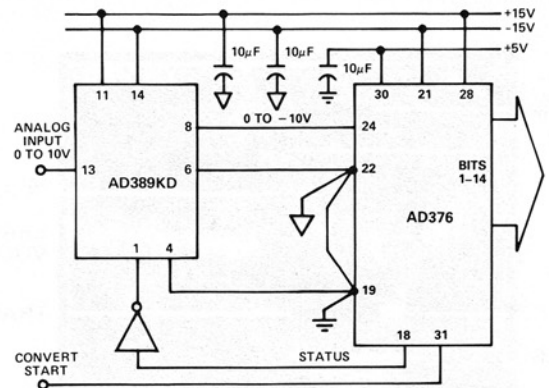

Figure 12. 20kHz-14-Bit, A/D Conversion System

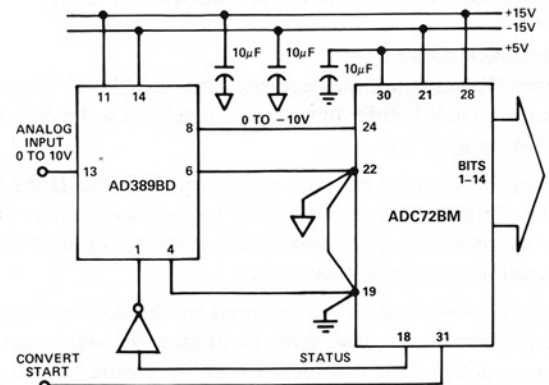

Figure 13. 8.3kHz-14-Bit, A/D Conversion System for -25 $^{\circ}$ C to +85 $^{\circ}$ C Operation

In sampled data systems there are two limiting factors in digitizing high frequency signals. The first limitation is the bandwidth and aperture uncertainty of the sample-and-hold amplifier. The second limitation is the maximum update rate for the T/H and A/D converter combination. For high throughput rate data acquisition systems all factors must be understood.

The aperture jitter is a result of noise within the switching network which modulates the phase of the hold command and is manifested in the variations in the value of the analog input that has been held. The aperture error which results from this jitter is directly related to the dV/dt of the analog input which is easily calculated as shown below. The error calculation takes into account the desired accuracy corresponding to the resolution of the A/D converter.

$$F_{\max} = \frac{(\text{Full Scale Voltage}) (2^{-N})}{(\text{Full Scale Voltage}) (2\pi) (\text{Aperture Jitter})}$$

For an application with a 14-bit A/D converter with a 10V full scale:

$$F_{\max} = \frac{(10) 2^{-14}}{(10) (2\pi) (4 \times 10^{-10} \text{ sec})} = 24\text{kHz}$$

For an application with a 12-bit A/D converter with a 10V full scale:

$$F_{\max} = \frac{(10) 2^{-12}}{(10) (2\pi) (4 \times 10^{-10} \text{ sec})} = 97\text{kHz}$$

Note that some additional aperture delay and jitter are added if the AD389 is not driven directly from the convert start line, but from the status line, which from some converters is delayed.

The maximum throughput rate is the sum of the sample-and-hold acquisition time, settling time and the A/D conversion time.

The maximum input frequency is constrained by the Nyquist sampling theorem to be half of the maximum throughput rate. Input frequencies higher than half the maximum throughput rate result in "under sampling" or aliasing errors of the input signal. In the following table the maximum input frequency is reported as half of the throughput rate, with an ideal brickwall low pass filter has been placed in the signal path prior to the AD389 and A/D converter to eliminate aliasing.

AD389 in Combination With an	Throughput Rate	Input Frequency Range
ADC71 (13 bit)	22.2kHz	dc to 11.1kHz
ADC72 (14 bit)	16.7kHz	dc to 8.3kHz
AD376 (14 bit)	40.0kHz	dc to 20kHz

Table I. T/H & ADC Combinations and Maximum Throughput Rate

OFFSET ADJUST TRIM

In most data acquisition systems only one offset adjustment is made. In many cases it is the offset adjust of the ADC that is used to cancel all other accumulated system offsets. The offset or pedestal of the AD389 can be nulled by means of 5kΩ potentiometer between pins 7, 9, and 11. If the offset of the AD389 is not adjusted, then connect pins 7 and 9 to pin 14, the negative supply. Otherwise the high impedance of the null pin together with parasitic capacitances can cause tail effects.

T/H REQUIREMENTS FOR HIGH RESOLUTION APPLICATIONS

The characteristics required for high resolution track-and-hold amplifiers are low feedthrough, low pedestal shifts with changes of input signal or temperature, high linearity, low temperature coefficients, and minimal droop rate.

For sampling a 20kHz signal to 14 bit and 16 bits for example, the following specs are required:

Spec	14 Bit	16 Bit	AD389KD	Units
Aperture Jitter (max)	2.4	0.6	0.4	ns
Slew Rate (max w/20V pk-pk signal)	1.26	1.26	30	V/μs
Feedthrough (1LSB max)	-84.3	-96.3	-86	dB
Droop Rate (1LSB max in 15μs)	40.7	10.2	0.1	μV/μs
Droop Rate (1LSB max in 50μs)	12.2	3.0	0.1	μV/μs
Acquisition Time (to ± 1LSB max) for 20kHz Signal w/15μs ADC	10	10	3-5	μs
Pedestal Shift (max) with Input Signal	-84.3	-96.3	-86	dB
Gain Temperature Coefficient (max) for ± 10°C Ambient Operation	6.1	1.5	2.0	ppm/°C
Thermal Tail (max) within 50μs after Hold	1.2	0.3	0.1	mV
Linearity Error (max)	± 0.0061	0.0015	0.003	%FSR

Table II. T/H Amplifier Requirements vs. AD389 Specs

Aperture jitter will affect exactly when the switch closes, even though the T/H control line is driven by a very precise clock. All high speed sampled data systems are very dependent on low aperture jitter for digitizing high frequency signals for spectrum analysis and accurate signal reconstruction.

The T/H amplifier slew rate determines the maximum frequency tracking rate and part of the settling time when sampling pulses and square waves. The feedthrough from input to output while in the hold mode should be less than 1LSB. The amplitude of 1LSB of the companion A/D converter for a given input range will vary from 610μV for a 14-bit A/D using a 0 to 10V input range to 4.88mV for a 12-bit A/D using a ± 10V input range. The hold mode droop rate should produce less than 1LSB of droop in the output during the conversion time of the A/D converter. For 610μV/LSB, as noted in the example above, for a 50μs 14-bit A/D converter, the maximum droop rate will be 610μV/50μs or 12μV/μs during the 50μs conversion period.

The linearity error should be less than 1LSB over the transfer function, as set by the resolution of the A/D converter. The T/H acquisition time, T/H settling time along, with the conversion time of the A/D converter determines the highest sampling rate. This in turn will determine the highest input signal frequency that can be sampled at twice a cycle per the Nyquist criteria. The pedestal shift due to input signal changes should either be linear, to be seen as a gain error, or negligible as with the feed-through spec. The temperature coefficients for drift should be low enough such that full accuracy is maintained over some minimum temperature range. The droop rate and pedestal will shift more over temperature above +70°C (+158°F). For commercial and industrial users, these shifts will only appear above the highest temperatures their equipment will ever expect to experience. Most precision instrumentation is installed only in human inhabitable work spaces or in controlled enclosures if the area has a hostile environment.

Minimal thermal tail effects are another requirement of high resolution applications. The self-heating errors induced by the changing current levels in the output stages of T/H amps may cause more than 1LSB of error due to thermal tail effects. The performance of a typical AD389 in contrast to a typical 12-bit T/H circuit is shown in Figures 11a. and 11b. The test circuit is shown in Figure 8.



LittleDiode supplies new, hard to find or obsolete electronic components and semiconductors all over the world.

With over two million different components listed you are sure to find the part you need.

Feel free to visit us today at our online store:

LittleDiode.com

Looking forward to providing you with the best possible service.