

#### FEATURES

- 12-Bit Resolution and Accuracy**
- Fast Conversion Time**
  - AD7572XX05: 5 $\mu$ s
  - AD7572XX12: 12.5 $\mu$ s
- Complete with On-Chip Reference**
- Fast Bus Access Time: 90ns**
- Low Power: 135mW**
- Small, 0.3", 24-Pin Package**  
and 28-Terminal Surface Mount Packages

#### GENERAL DESCRIPTION

The AD7572 is a complete, 12-bit ADC that offers high speed performance combined with low, CMOS power levels. The AD7572 uses an accurate, high speed DAC and comparator in a successive-approximation loop to achieve a fast conversion time. An on-chip, buried Zener diode provides a stable reference voltage to give low drift performance over the full temperature range and the specified accuracy is achieved without any user trims. An on-chip clock circuit is provided, which may be used with a crystal for stand-alone operation, or the clock input may be driven from an external clock source such as a divided-down microprocessor clock. The only other external components required for basic operation of the AD7572 are decoupling capacitors for the supply voltages and reference output.

The AD7572 has a high speed digital interface with three-state data outputs and can operate under the control of standard microprocessor Read ( $\overline{RD}$ ) and decoded address ( $\overline{CS}$ ) signals. Interface timing is sufficiently fast to allow the AD7572 to operate with most popular microprocessors, with three-state enable times of only 90ns and bus relinquish times of 75ns.

The AD7572 is fabricated in Analog Devices Linear Compatible CMOS process (LC<sup>2</sup>MOS), an advanced, all ion-implanted process that combines fast CMOS logic and linear, bipolar circuits on a single chip, thus achieving excellent linear performance while still retaining low CMOS power levels.

The AD7572 is available in both 0.3" wide, 24-pin DIPs and in a 28-terminal plastic leaded chip carrier (PLCC) and leadless ceramic chip carrier (LCCC).

#### REV. A

Information furnished by Analog Devices is believed to be accurate and reliable. However, no responsibility is assumed by Analog Devices for its use, nor for any infringements of patents or other rights of third parties which may result from its use. No license is granted by implication or otherwise under any patent or patent rights of Analog Devices.

#### FUNCTIONAL BLOCK DIAGRAM

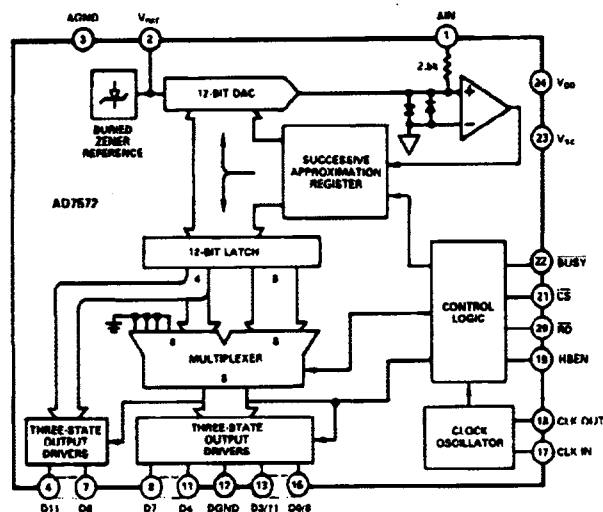

#### PRODUCT HIGHLIGHTS

1. Fast, 5 $\mu$ s and 12.5 $\mu$ s conversion times make the AD7572 ideal for a wide range of applications in telecommunications, sonar and radar signal processing or any wideband data acquisition system.
2. On-chip buried-Zener reference has temperature coefficient as low as 25ppm/ $^{\circ}$ C, giving low full-scale drift over the operating temperature range.
3. Stable DAC and comparator give excellent linearity and low zero error over the full temperature range.
4. Fast, easy-to-use digital interface has three-state bus access times of 90ns and bus relinquish times of 75ns, allowing the AD7572 to interface to most popular microprocessors.
5. LC<sup>2</sup>MOS circuitry gives low power drain (135mW) from +5, -15 volt supplies.
6. 24-pin 0.3" package offers space saving over parts in 28-pin 0.6" DIP.

( $V_{DD} = 5V \pm 5\%$ ,  $V_{SS} = -15V \pm 5\%$ ,  $f_{CLK} = 2.5MHz$  for AD7572XX05, 1MHz for AD7572XX12. All Specifications  $T_{min}$  to  $T_{max}$  unless otherwise noted. Specifications apply to Slow Memory Mode.)

# AD7572—SPECIFICATIONS

Parameter	J, A, S Versions <sup>1</sup>	K, B, T Versions	L Version	C, U Versions	Units	Test Conditions/Comments
<b>ACCURACY</b>						
Resolution	12	12	12	12	Bits	
Integral Nonlinearity @ +25°C	±1	±1	±1/2	±1/2	LSB max	
$T_{min}$ to $T_{max}$	±1	±1	±1/2	±3/4	LSB max	
Differential Nonlinearity	±1	±1	±1	±1	LSB max	
Minimum Resolution for which no Missing Codes are Guaranteed	12	12	12	12	Bits	
Offset Error @ +25°C	±4	±3	±3	±3	LSB max	
$T_{min}$ to $T_{max}$	±6	±5	±4	±4	LSB max	
Full Scale (FS) Error <sup>2</sup> @ +25°C	±15	±10	±10	±10	LSB max	Typical Change over Temp Is ±1LSB $V_{DD} = 5V$ ; $V_{SS} = -15V$ ; FS = 5V
Full Scale TC <sup>3,4</sup>	45	25	25	25	ppm/°C max	Ideal Last Code Transition = FS - 3/2LSBs
<b>ANALOG INPUT</b>						
Input Voltage Range	0 to +5	0 to +5	0 to +5	0 to +5	Volts	For Bipolar Operation See Figures 10 & 12
Input Current	3.5	3.5	3.5	3.5	mA max	
<b>INTERNAL REFERENCE VOLTAGE</b>						
$V_{REF}$ Output @ +25°C	-5.2/-5.3	-5.2/-5.3	-5.2/-5.3	-5.2/-5.3	V min/V max	-5.25V ±1%
$V_{REF}$ Output TC	40	20	20	20	ppm/°C typ	
Output Current Sink Capability	550	550	550	550	μA max	External Load Should Not Change During Conversion
<b>POWER SUPPLY REJECTION</b>						
$V_{DD}$ Only	±1/2	±1/2	±1/2	±1/2	LSB typ	FS Change, $V_{SS} = -15V$ $V_{DD} = +4.75V$ to $+5.25V$
$V_{SS}$ Only	±1/2	±1/2	±1/2	±1/2	LSB typ	FS Change, $V_{DD} = 5V$ $V_{SS} = -14.25V$ to $-15.75V$
<b>LOGIC INPUTS</b>						
$\overline{CS}$ , $\overline{RD}$ , HBEN, CLK IN						
$V_{INL}$ , Input Low Voltage	+0.8	+0.8	+0.8	+0.8	V max	$V_{DD} = 5V \pm 5\%$
$V_{INH}$ , Input High Voltage	+2.4	+2.4	+2.4	+2.4	V min	
$C_{IN}$ , <sup>5</sup> Input Capacitance	10	10	10	10	pF max	
$\overline{CS}$ , $\overline{RD}$ , HBEN						
$I_{IN}$ , Input Current	±10	±10	±10	±10	μA max	$V_{IN} = 0$ to $V_{DD}$
CLK IN						
$I_{IN}$ , Input Current	±20	±20	±20	±20	μA max	$V_{IN} = 0$ to $V_{DD}$
<b>LOGIC OUTPUTS</b>						
D11-D0/8, $\overline{BUSY}$ , CLK OUT						
$V_{OL}$ , Output Low Voltage	+0.4	+0.4	+0.4	+0.4	V max	$I_{SINK} = 1.6mA$
$V_{OH}$ , Output High Voltage	+4.0	+4.0	+4.0	+4.0	V min	$I_{SOURCE} = 200\mu A$
D11-D0/8						
Floating State Leakage Current	±10	±10	±10	±10	μA max	
Floating State Output Capacitance <sup>5</sup>	15	15	15	15	pF max	
<b>CONVERSION TIME</b>						
<b>AD7572XX05</b>						
Synchronous Clock	5	5	5	5	μs max	$f_{CLK} = 2.5MHz$ . See Under Control Inputs Synchronization
Asynchronous Clock	4.8/5.2	4.8/5.2	4.8/5.2	4.8/5.2	μs min/max	
<b>AD7572XX12</b>						
Synchronous Clock	12.5	12.5	12.5	12.5	μs max	$f_{CLK} = 1MHz$
Asynchronous Clock	12/13	12/13	12/13	12/13	μs min/μs max	
<b>POWER REQUIREMENTS</b>						
$V_{DD}$	+5	+5	+5	+5	V NOM	±5% for Specified Performance
$V_{SS}$	-15	-15	-15	-15	V NOM	±5% for Specified Performance
$I_{DD}$ <sup>6</sup>	7	7	7	7	mA max	$\overline{CS} = \overline{RD} = V_{DD}$ , AIN = 5V
$I_{SS}$ <sup>6</sup>	12	12	12	12	mA max	$\overline{CS} = \overline{RD} = V_{DD}$ , AIN = 5V
Power Dissipation	135	135	135	135	mW typ	
	215	215	215	215	mW max	

### NOTES

<sup>1</sup>Temperature range as follows: J, K, L Versions; 0 to +70°C.

A, B, C Versions; -25°C to +85°C.

S, T, U Versions; -55°C to +125°C.

<sup>2</sup>Includes internal voltage reference error.

<sup>3</sup>Full-Scale TC =  $\Delta FS/\Delta T$ , where  $\Delta FS$  is Full-Scale change from  $T_A = +25^\circ C$  to  $T_{max}$  or  $T_{min}$ .

<sup>4</sup>Includes internal voltage reference drift.

<sup>5</sup>Sample tested to ensure compliance.

<sup>6</sup>Power supply current is measured when AD7572 is inactive, i.e.,  $\overline{CS} = \overline{RD} = \overline{BUSY} = HIGH$ .

Specifications subject to change without notice.

**TIMING CHARACTERISTICS<sup>1</sup>** ( $V_{DD} = 5V, V_{SS} = -15V$ )

Parameter	Limit at +25°C (All Grades)	Limit at $T_{min}, T_{max}$ (J, K, L, A, B, C Grades)	Limit at $T_{min}, T_{max}$ (S, T, U Grades)	Units	Conditions/Comments
$t_1$	0	0	0	ns min	$\overline{CS}$ to $\overline{RD}$ Setup Time
$t_2$	190	230	270	ns max	$\overline{RD}$ to $\overline{BUSY}$ Propagation Delay
$t_3^2$	90	110	120	ns max	Data Access Time after $\overline{RD}$ , $C_L = 20pF$
	125	150	170	ns max	Data Access Time after $\overline{RD}$ , $C_L = 100pF$
$t_4$	$t_3$	$t_3$	$t_3$	ns min	$\overline{RD}$ Pulse Width
$t_5$	0	0	0	ns min	$\overline{CS}$ to $\overline{RD}$ Hold Time
$t_6^2$	70	90	100	ns max	Data Setup Time after $\overline{BUSY}$
$t_7^3$	20	20	20	ns min	Bus Relinquish Time
	75	85	90	ns max	
$t_8$	0	0	0	ns min	HBEN to $\overline{RD}$ Setup Time
$t_9$	0	0	0	ns min	HBEN to $\overline{RD}$ Hold Time
$t_{10}$	200	200	200	ns min	Delay Between Successive Read Operations

**NOTES**

<sup>1</sup>Timing Specifications are sample tested at +25°C to ensure compliance. All input control signals are specified with  $t_r = t_f = 5ns$  (10% to 90% of +5V) and timed from a voltage level of 1.6V.

<sup>2</sup> $t_3$  and  $t_6$  are measured with the load circuits of Figure 1 and defined as the time required for an output to cross 0.8V or 2.4V.

<sup>3</sup> $t_7$  is defined as the time required for the data lines to change 0.5V when loaded with the circuits of Figure 2.

Specifications subject to change without notice.

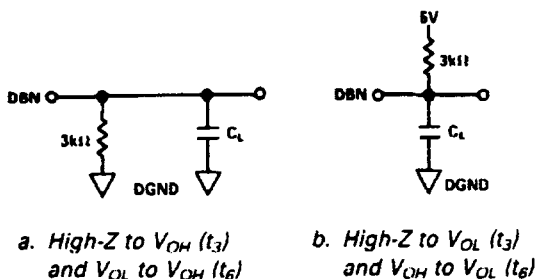

Figure 1. Load Circuits for Access Time

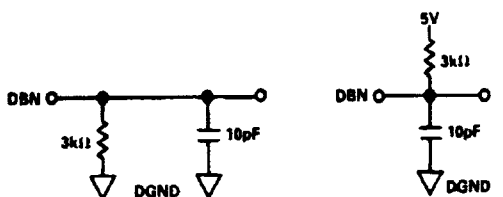

Figure 2. Load Circuits for Output Float Delay

**ABSOLUTE MAXIMUM RATINGS\***

( $T_A = +25^\circ C$  unless otherwise noted)

- $V_{DD}$  to DGND . . . . . -0.3V to +7V
- $V_{SS}$  to DGND . . . . . +0.3V to -17V
- AGND to DGND . . . . . -0.3V,  $V_{DD} + 0.3V$
- AIN to AGND . . . . . -15V to +15V
- Digital Input Voltage to DGND  
(CLK IN, HBEN,  $\overline{RD}$ ,  $\overline{CS}$ ) . . . . . -0.3V,  $V_{DD} + 0.3V$
- Digital Output Voltage to DGND  
(D11-D0/8, CLK OUT,  $\overline{BUSY}$ ) . . . . . -0.3V,  $V_{DD} + 0.3V$
- Operating Temperature Range
  - Commercial (J, K, L Versions) . . . . . 0 to +70°C
  - Industrial (A, B, C Versions) . . . . . -25°C to +85°C
  - Extended (S, T, U Versions) . . . . . -55°C to +125°C
- Storage Temperature . . . . . -65°C to +150°C
- Lead Temperature (Soldering, 10secs) . . . . . +300°C
- Power Dissipation (Any Package) to +75°C . . . . . 1,000mW
- Derates above +75°C by . . . . . 10mW/°C

\*Stress above those listed under "Absolute Maximum Ratings" may cause permanent damage to the device. This is a stress rating only and functional operation of the device at these or any other condition above those indicated in the operational sections of this specification is not implied. Exposure to absolute maximum rating conditions for extended periods may affect device reliability.

**CAUTION**

ESD (electrostatic discharge) sensitive device. The digital control inputs are diode protected; however, permanent damage may occur on unconnected devices subject to high energy electrostatic fields. Unused devices must be stored in conductive foam or shunts. The protective foam should be discharged to the destination socket before devices are removed.



# AD7572

## ORDERING GUIDE<sup>1</sup>

Model <sup>2</sup>	Conversion Time	Temperature Range	Full-Scale TC	Accuracy Grade	Package Option <sup>3</sup>
AD7572JN05	5μs	0 to +70°C	45ppm/°C	±1LSB	N-24
AD7572KN05	5μs	0 to +70°C	25ppm/°C	±1LSB	N-24
AD7572LN05	5μs	0 to +70°C	25ppm/°C	±1/2LSB	N-24
AD7572JP05	5μs	0 to +70°C	45ppm/°C	±1LSB	P-28A
AD7572KP05	5μs	0 to +70°C	25ppm/°C	±1LSB	P-28A
AD7572LP05	5μs	0 to +70°C	25ppm/°C	±1/2LSB	P-28A
AD7572AQ05	5μs	-25°C to +85°C	45ppm/°C	±1LSB	Q-24
AD7572BQ05	5μs	-25°C to +85°C	25ppm/°C	±1LSB	Q-24
AD7572CQ05	5μs	-25°C to +85°C	25ppm/°C	±1/2LSB	Q-24
AD7572SQ05	5μs	-55°C to +125°C	45ppm/°C	±1LSB	Q-24
AD7572TQ05	5μs	-55°C to +125°C	25ppm/°C	±1LSB	Q-24
AD7572UQ05	5μs	-55°C to +125°C	25ppm/°C	±1/2LSB	Q-24
AD7572SE05	5μs	-55°C to +125°C	45ppm/°C	±1LSB	E-28A
AD7572TE05	5μs	-55°C to +125°C	25ppm/°C	±1LSB	E-28A
AD7572UE05	5μs	-55°C to +125°C	25ppm/°C	±1/2LSB	E-28A
AD7572JN12	12.5μs	0 to +70°C	45ppm/°C	±1LSB	N-24
AD7572KN12	12.5μs	0 to +70°C	25ppm/°C	±1LSB	N-24
AD7572LN12	12.5μs	0 to +70°C	25ppm/°C	±1/2LSB	N-24
AD7572JP12	12.5μs	0 to +70°C	45ppm/°C	±1LSB	P-28A
AD7572KP12	12.5μs	0 to +70°C	25ppm/°C	±1LSB	P-28A
AD7572LP12	12.5μs	0 to +70°C	25ppm/°C	±1/2LSB	P-28A
AD7572AQ12	12.5μs	-25°C to +85°C	45ppm/°C	±1LSB	Q-24
AD7572BQ12	12.5μs	-25°C to +85°C	25ppm/°C	±1LSB	Q-24
AD7572CQ12	12.5μs	-25°C to +85°C	25ppm/°C	±1/2LSB	Q-24
AD7572SQ12	12.5μs	-55°C to +125°C	45ppm/°C	±1LSB	Q-24
AD7572TQ12	12.5μs	-55°C to +125°C	25ppm/°C	±1LSB	Q-24
AD7572UQ12	12.5μs	-55°C to +125°C	25ppm/°C	±1/2LSB	Q-24
AD7572SE12	12.5μs	-55°C to +125°C	45ppm/°C	±1LSB	E-28A
AD7572TE12	12.5μs	-55°C to +125°C	25ppm/°C	±1LSB	E-28A
AD7572UE12	12.5μs	-55°C to +125°C	25ppm/°C	±1/2LSB	E-28A

### NOTES

- Analog Devices Reserves the right to ship ceramic (D-24A) in lieu cerdip (Q-24) hermetic package.
- To order MIL-STD-883, Class B processed parts, add /883B to part number. Contact your local sales office for military data sheet. For U.S. Standard Military Drawing (SMD) see DESC Drawing #5962-87591.
- D = Ceramic DIP; E = Leadless Ceramic Chip Carrier (LCCC); N = Plastic DIP; P = Plastic Leaded Chip Carrier (PLCC); Q = Cerdip.

## PIN CONFIGURATIONS

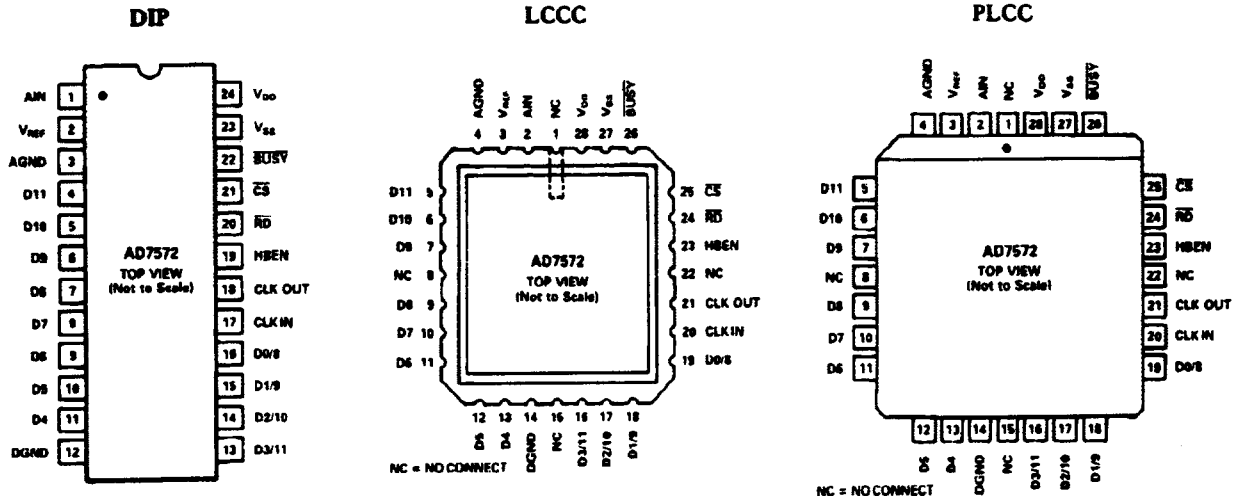

## PIN FUNCTION DESCRIPTION

DIP Pin No.	Mnemonic	Description
1	AIN	Analog Input.
2	V <sub>REF</sub>	Voltage Reference Output. The AD7572 has its own internal -5.25V reference.
3	AGND	Analog Ground.
4 . . . 11	D11 . . . D4	Three State data outputs. They become active when $\overline{CS}$ and $\overline{RD}$ are brought low.
13 . . . 16	D3/11 . . . D0/8	Individual pin function is dependent upon High Byte Enable (HBEN) Input.

### DATA BUS OUTPUT, $\overline{CS}$ & $\overline{RD}$ = LOW

	Pin 4	Pin 5	Pin 6	Pin 7	Pin 8	Pin 9	Pin 10	Pin 11	Pin 13	Pin 14	Pin 15	Pin 16
MNEMONIC*	D11	D10	D9	D8	D7	D6	D5	D4	D3/11	D2/10	D1/9	D0/8
HBEN = LOW	DB11	DB10	DB9	DB8	DB7	DB6	DB5	DB4	DB3	DB2	DB1	DB0
HBEN = HIGH	DB11	DB10	DB9	DB8	LOW	LOW	LOW	LOW	DB11	DB10	DB9	DB8

**NOTE**

\*D11 . . . D0/8 are the ADC data output pins.  
DB11 . . . DB0 are the 12-bit conversion results, DB11 is the MSB.

12	DGND	Digital Ground.
17	CLK IN	Clock Input pin. An external TTL compatible clock may be applied to this pin. Alternatively a crystal or ceramic resonator may be connected between CLK IN (Pin 17) and CLK OUT (Pin 18).
18	CLK OUT	Clock Output Pin. An inverted CLK IN signal appears at CLK OUT when an external clock is used. See CLK IN (Pin 17) description for crystal (resonator).
19	HBEN	High Byte Enable input. Its primary function is to multiplex the 12-bits of conversion data onto the lower D7 . . . D0/8 outputs (4MSBs or 8 LSBs). See Pin description 4 . . . 11 and 13 . . . 16. It also disables conversion start when HBEN is high.
20	$\overline{RD}$	READ input. This active LOW signal, in conjunction with $\overline{CS}$ is used to enable the output data three state drivers and initiate a conversion if $\overline{CS}$ and HBEN are low.
21	$\overline{CS}$	CHIP SELECT Input. This active LOW signal, in conjunction with $\overline{RD}$ is used to enable the output data three state drivers and initiate a conversion if $\overline{RD}$ and HBEN are low.
22	$\overline{BUSY}$	$\overline{BUSY}$ output indicates converter status. $\overline{BUSY}$ is LOW during conversion.
23	V <sub>SS</sub>	Negative Supply, -15V.
24	V <sub>DD</sub>	Positive Supply, +5V.

### ORDERING INFORMATION<sup>1,2</sup>

#### CONVERSION TIME = 5 $\mu$ s

Full-Scale TC	Accuracy Grade	Temperature Range and Package Options		
		0 to +70°C	-25°C to +85°C	-55°C to +125°C
45ppm/°C 25ppm/°C 25ppm/°C	± 1LSB ± 1LSB ± 1/2LSB	Plastic DIP	Hermetic <sup>3</sup> DIP	Hermetic <sup>3</sup> DIP
		AD7572JN05	AD7572AQ05	AD7572SQ05
		AD7572KN05	AD7572BQ05	AD7572TQ05
		AD7572LN05	AD7572CQ05	AD7572UQ05
45ppm/°C 25ppm/°C 25ppm/°C	± 1LSB ± 1LSB ± 1/2LSB	PLCC <sup>3</sup>		LC <sup>4</sup>
		AD7572JP05		AD7572SE05
		AD7572KP05		AD7572TE05
		AD7572LP05		AD7572UE05

#### CONVERSION TIME = 12.5 $\mu$ s

Full-Scale TC	Accuracy Grade	Temperature Range and Package Options		
		0 to +70°C	-25°C to +85°C	-55°C to +125°C
45ppm/°C 25ppm/°C 25ppm/°C	± 1LSB ± 1LSB ± 1/2LSB	Plastic DIP	Hermetic <sup>3</sup> DIP	Hermetic <sup>3</sup> DIP
		AD7572JN12	AD7572AQ12	AD7572SQ12
		AD7572KN12	AD7572BQ12	AD7572TQ12
		AD7572LN12	AD7572CQ12	AD7572UQ12
45ppm/°C 25ppm/°C 25ppm/°C	± 1LSB ± 1LSB ± 1/2LSB	PLCC <sup>3</sup>		LC <sup>4</sup>
		AD7572JP12		AD7572SE12
		AD7572KP12		AD7572TE12
		AD7572LP12		AD7572UE12

**NOTES**

<sup>1</sup>To order MIL-STD-883, Class B processed parts, add /883 to part number. Contact your local sales office for military data sheet.  
<sup>2</sup>Analog Devices reserves the right to ship either cerdip or ceramic hermetic packages.  
<sup>3</sup>PLCC: Plastic Leaded Chip Carrier.  
<sup>4</sup>LC<sup>4</sup>: Leadless Ceramic Chip Carrier.

### OPERATIONAL DIAGRAM

An operational diagram for the AD7572 is shown in Figure 3. The AD7572 is a 12-bit successive approximation A/D converter. The addition of just a crystal/ceramic resonator and a few capacitors enables the device to perform the analog-to-digital function.

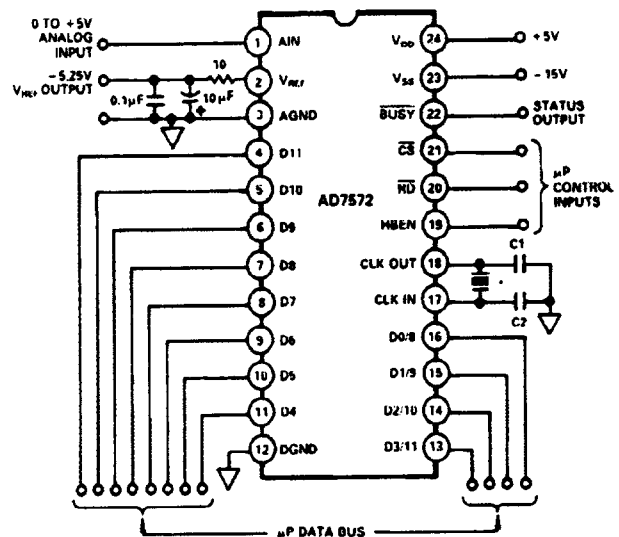

**NOTES**  
AD7572XX05 - 2.5MHz CRYSTAL/CERAMIC RESONATOR.  
AD7572XX12 - 1.0MHz CRYSTAL/CERAMIC RESONATOR.  
C1 and C2 CAPACITANCE VALUES DEPEND ON CRYSTAL/CERAMIC RESONATOR MANUFACTURER. TYPICAL VALUES ARE FROM 20 to 100pF.

Figure 3. AD7572 Operational Diagram

# AD7572

## CONVERTER DETAILS

Conversion start is controlled by the  $\overline{CS}$ ,  $\overline{RD}$  and HBEN inputs. At the start of conversion the successive approximation register (SAR) is reset and the three-state data outputs are enabled. Once a conversion cycle has begun it cannot be re-started.

During conversion, the internal 12-bit voltage mode DAC output is sequenced by the SAR from the most significant bit (MSB) to the least significant bit (LSB). Referring to Figure 4, the AIN input connects to the comparator input via  $2.5k\Omega$ . The DAC which has a similar  $2.5k\Omega$  output impedance connects to the same comparator input. Bit decisions are made by the comparator (zero crossing detector) which checks the addition of each successive weighted bit from the DAC output. The MSB decision is made 80ns (typically) after the second falling edge of CLK IN following a conversion start. Similarly, the succeeding bit decisions are made approximately 80ns after a CLK IN edge until conversion is finished. At the end of conversion, the DAC output current balances the AIN input current. The SAR contents (12-bit data word) which represent the AIN input signal is loaded into a 12-bit latch.

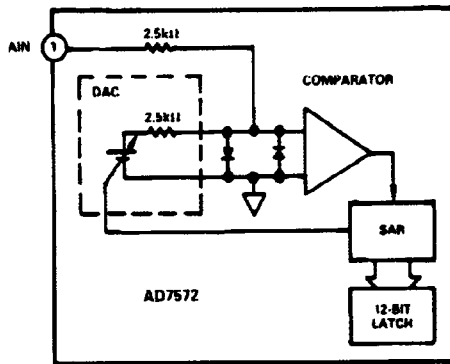

Figure 4. AD7572 AIN Input

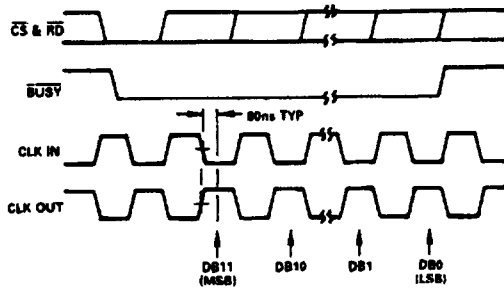

Figure 5. Operating Waveforms Using an External Clock Source for CLK IN

## CONTROL INPUTS SYNCHRONIZATION

In applications where the  $\overline{RD}$  control input is not synchronized with the ADC clock then conversion time can vary from 12 to 13 CLK IN periods. This is because the ADC waits for the first falling CLK IN edge after conversion start before the conversion procedure begins. Without synchronization, this delay can vary from zero to an entire clock period. If a constant conversion time is required, then the following approach ensures a fixed  $5\mu s$  conversion time for the AD7572XX05 and  $12.5\mu s$  for the AD7572XX12: when initiating a conversion,  $\overline{RD}$  must go low on either the rising edge of CLK IN or the falling edge of CLK OUT.

## DRIVING THE ANALOG INPUT

During conversion, the AIN input current is modulated by the DAC output current at a rate equal to the CLK IN frequency (i.e., 2.5MHz when CLK IN = 2.5MHz). The analog input voltage must remain fixed during this period and as a result must be driven from an op amp or sample hold with a low output impedance. The output impedance of an op amp is equal to the open loop output impedance divided by the loop gain at the frequency of interest.

Suitable devices capable of driving the AD7572 AIN input are the AD OP-27 and AD711 op amps or the AD585 sample hold.

## INTERNAL CLOCK OSCILLATOR

Figure 6 shows the AD7572 internal clock circuit. A crystal or ceramic resonator may be connected between CLK IN (Pin 17) and CLK OUT (Pin 18) to provide a clock oscillator for the ADC timing. Alternatively the crystal/resonator may be omitted and an external clock source may be connected to CLK IN. For an external clock the mark/space ratio must be 50/50. An inverted CLK IN signal will appear at the CLK OUT pin as shown in the operating waveforms of Figure 5.

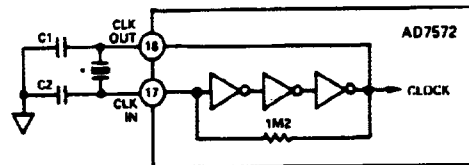

NOTES  
AD7572XX06 - 2.5MHz CRYSTAL/CERAMIC RESONATOR.  
AD7572XX12 - 1.0MHz CRYSTAL/CERAMIC RESONATOR.  
C1 and C2 CAPACITANCE VALUES DEPEND ON CRYSTAL/CERAMIC RESONATOR MANUFACTURER. TYPICAL VALUES ARE FROM 30 TO 100pF.

Figure 6. AD7572 Internal Clock Circuit

## INTERNAL REFERENCE

The AD7572 has an on-chip, buffered, temperature-compensated, buried Zener reference, which is factory trimmed to  $-5.25V \pm 1\%$ . It is internally connected to the DAC and is also available at Pin 2 to provide up to  $550\mu A$  current to an external load.

For minimum code transition noise the reference output should be decoupled with a capacitor to filter out wideband noise from the reference diode ( $10\mu F$  of tantalum in parallel with  $100nF$  ceramic). However, large values of decoupling capacitor can affect the dynamic response and stability of the reference amplifier. A  $10\Omega$  resistor in series with the decoupling capacitors will eliminate this problem without adversely affecting the filtering effect of the capacitors. A simplified schematic of the reference with its recommended decoupling components is shown in Figure 7.

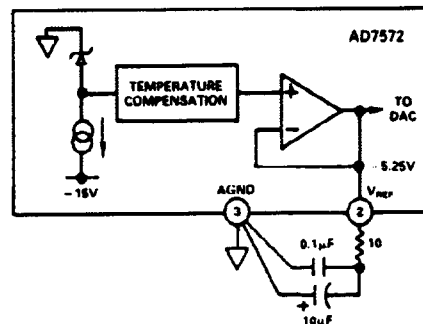

Figure 7. AD7572 Internal  $-5.25V$  Reference

**UNIPOLAR OPERATION**

Figure 8 shows the ideal input/output characteristic for the 0 to 5 volt input range of the AD7572. The designed code transitions occur midway between successive integer LSB values (i.e., 1/2LSB, 3/2LSBs, 5/2LSBs . . . FS-3/2LSBs). The output code is natural binary with 1LSB = FS/4096 = (5/4096)V = 1.22mV.

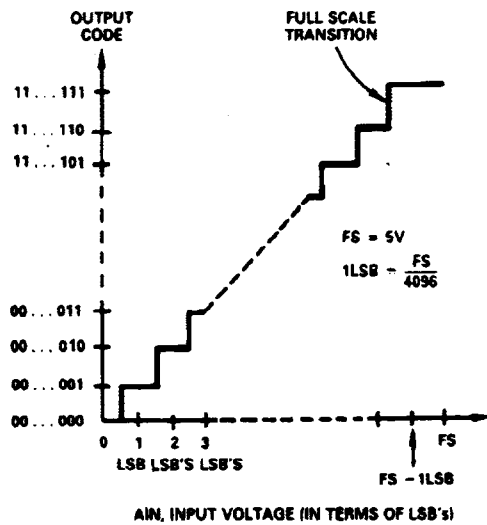

Figure 8. AD7572 Ideal Input/Output Transfer Characteristic

**UNIPOLAR OFFSET AND FULL-SCALE ERROR ADJUSTMENT**

In applications where absolute accuracy is important then offset and full-scale error can be adjusted to zero. Offset error must be adjusted before full-scale error. Figure 9 shows the extra components required for full-scale error adjustment. Zero offset is achieved by adjusting the offset of the op amp driving AIN (i.e., A1 in Figure 9.). For zero offset error apply 0.61mV (i.e., 1/2LSB) at  $V_{IN}$  and adjust the op amp offset voltage until the ADC output code flickers between 0000 0000 0000 and 0000 0000 0001.

For zero full-scale error apply an analog input of 4.99817V (i.e., FS-3/2LSBs or last code transition) at  $V_{IN}$  and adjust R1 until the ADC output code flickers between 1111 1111 1110 and 1111 1111 1111.

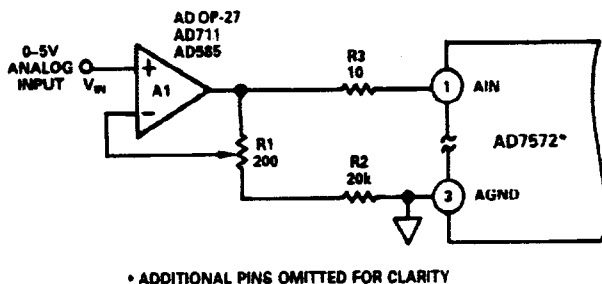

Figure 9. Unipolar 0 to +5V Operation with Gain Error Adjust

**BIPOLAR OPERATION**

Figures 10 and 12 show how bipolar operation can be achieved with the AD7572. Both circuits use an op-amp to offset the analog signal ( $V_{IN}$ ) by 2.5V. Alternatively, the op amp (A1) can be replaced by a sample hold as shown in Figure 24. The op amp transfer functions are given below:

Figure 10:  $A_{IN} = (V_{IN} + 2.5)$  volts

Figure 12:  $A_{IN} = (-V_{IN} + 2.5)$  volts

Both circuits have an analog input range of  $\pm 2.5V$  and an LSB size of 1.22mV. The output codes are offset binary for Figure 10 and complementary offset binary for Figure 12. Their ideal input/output transfer characteristics after offset and full scale adjustment are shown in Figures 11 and 13.

Signal ranges other than  $\pm 2.5V$  are easily accommodated using different values of R3 and R4 for Figure 10, and a different R2 value for Figure 12. These resistors should be chosen such that the voltage range at AIN covers the full dynamic range (i.e., 0V to 5V) of the ADC. All resistors should be the same type and from the same manufacturer so that their temperature coefficients match.

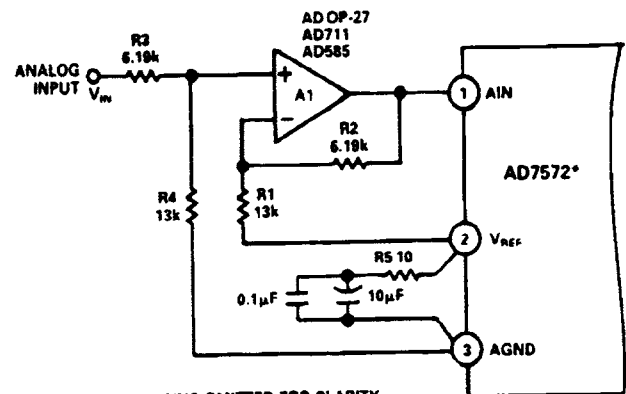

\*ADDITIONAL PINS OMITTED FOR CLARITY

Figure 10. AD7572 Bipolar Operation - Output Code is Offset Binary

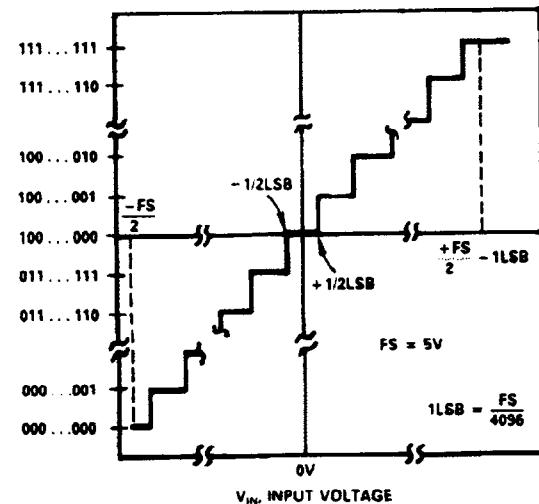
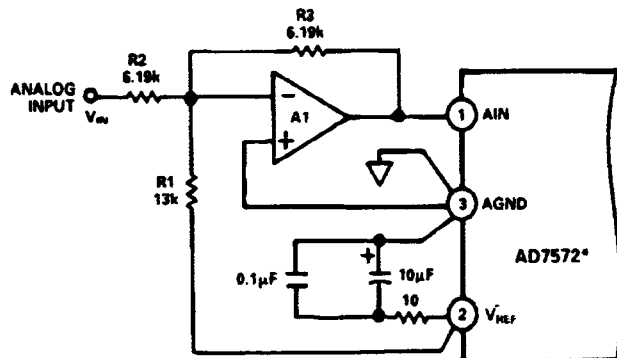

Figure 11. Ideal Input/Output Transfer Characteristic for the Bipolar Circuit of Figure 10

# AD7572



\*ADDITIONAL PINS OMITTED FOR CLARITY

Figure 12. AD7572 Bipolar Operation – Output Code is Complementary Offset Binary

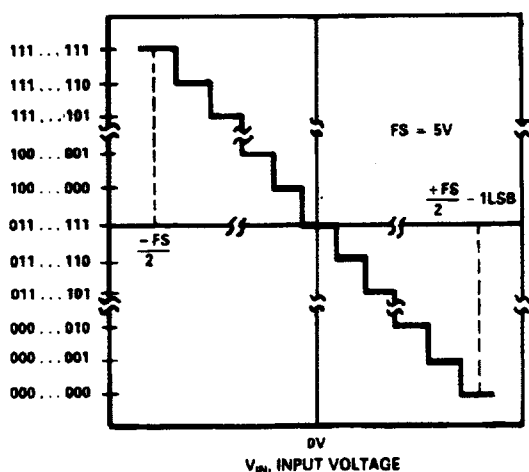
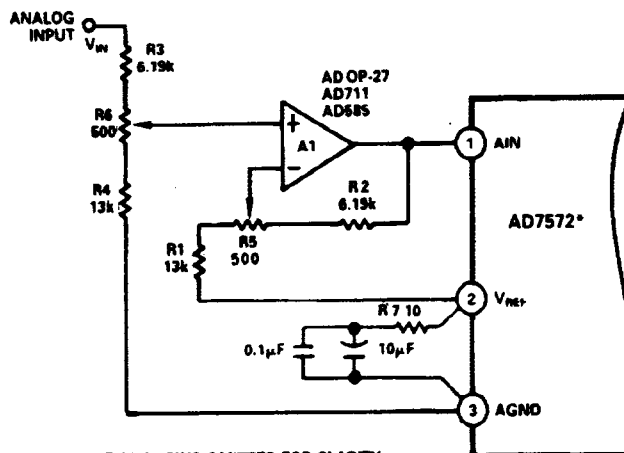

Figure 13. Ideal Input:Output Transfer Characteristic for the Bipolar Circuit of Figure 12

## OFFSET AND FULL-SCALE ERROR

In most Digital Signal Processing (DSP) applications offset and full-scale error have little or no effect on system performance. A typical example is a digital filter, where an analog signal is quantized, digitally processed and recreated using a DAC. In these type of applications the offset error can be eliminated by ac coupling the recreated signal. Full-scale error effect is linear and does not cause problems as long as the input signal is within the full dynamic range of the ADC. An important parameter in DSP applications is Differential Nonlinearity and this is not affected by either offset or full-scale error.

In measurement applications where absolute accuracy is required, offset and full-scale error can be adjusted to zero as in Figure 14.



\*ADDITIONAL PINS OMITTED FOR CLARITY

Figure 14. AD7572 Bipolar Operation with Offset and Gain Error Adjust

## BIPOLAR OFFSET AND FULL-SCALE ERROR ADJUSTMENT

The bipolar circuit of Figure 10 can be adjusted for offset and full-scale errors, by including two potentiometers R5 and R6, as shown in Figure 14. Offset must be adjusted before full-scale error. This is achieved by applying an analog input of 0.61mV (1/2LSB) at  $V_{IN}$  and adjusting R5 until the ADC output code flickers between 1000 0000 0000 and 1000 0000 0001.

For full-scale error adjustment, the analog input must be at 2.49817 volts (i.e.,  $FS/2 - 3/2LSBs$  or last transition point). Then R6 is adjusted until the ADC output code flickers between 1111 1111 1110 and 1111 1111 1111.

A similar offset and full-scale error adjustment procedure may be employed for Figure 12 by making R1 and R2 variable. Offset must again be adjusted before full scale error. This is achieved by applying an analog input of 0.61mV at  $V_{IN}$  and adjusting R1 until the ADC output code flickers between 0111 1111 1110 and 0111 1111 1111.

For full-scale error adjust, apply a signal source of 2.49817V at  $V_{IN}$  and adjust R2 until the ADC output code flickers between 0000 0000 0000 and 0000 0000 0001.

### APPLICATION HINTS

Wire wrap boards are not recommended for high resolution or high-speed A/D converters. To obtain the best performance from the AD7572 a printed circuit board is required. Layout for the printed circuit board should ensure that digital and analog signal lines are separated as much as possible. In particular, care should be taken not to run any digital track alongside an analog signal track or underneath the AD7572. The analog input should be screened by AGND.

A single point analog ground (STAR ground) separate from the logic system ground should be established at Pin 3 (AGND) or as close as possible to the AD7572 as shown in Figure 15.

Pin 12 (AD7572 DGND) and all other analog grounds should be connected to this single analog ground point. No other digital grounds should be connected to this analog ground point. Low impedance analog and digital power supply common returns are essential to low noise operation of the ADC and the foil width for these tracks should be as wide as possible.

**Noise:** Input signal leads to AIN and signal return leads from AGND (Pin 3) should be kept as short as possible to minimize input noise coupling. In applications where this is not possible, a shielded cable between source and ADC is recommended. Also, since any potential difference in grounds between the signal source and ADC appears as an error voltage in series with the input signal, attention should be paid to reducing the ground circuit impedances as much as possible.

In applications where the AD7572 data outputs and control signals are connected to a continuously active microprocessor bus, it is possible to get LSB errors in conversion results. These errors are due to feedthrough from the microprocessor to the successive approximation comparator. The problem can be eliminated by forcing the microprocessor into a WAIT state during conversion (see Slow Memory Mode interfacing), or by using three-state buffers to isolate the AD7572 data bus.

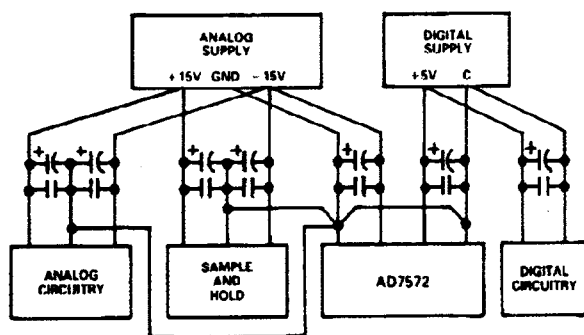

Figure 15. Power Supply Grounding Practice

### TIMING AND CONTROL

Conversion start and data read operations are controlled by three AD7572 digital inputs; HBEN,  $\overline{CS}$  and  $\overline{RD}$ . Figure 16 shows the logic structure associated with these inputs. The three signals are internally gated so that a logic "0" is required on all three inputs to initiate a conversion. Once initiated it cannot be re-started until conversion is complete. Converter status is indicated by the  $\overline{BUSY}$  output, and this is low while conversion is in progress.

There are two modes of operation as outlined by the timing diagrams of Figures 17 to 20. Slow Memory Mode is designed for microprocessors which can be driven into a WAIT state, a READ operation brings  $\overline{CS}$  and  $\overline{RD}$  low which initiates a conversion and data is read when conversion is complete. The second is the ROM Mode which does not require microprocessor WAIT states, a READ operation brings  $\overline{CS}$  and  $\overline{RD}$  low which initiates a conversion and reads the previous conversion result.

### DATA FORMAT

The output data format can either be a complete parallel load (DB11..DB0) for 16-bit microprocessors or a two byte load for 8-bit microprocessors. Data is always right justified (i.e., LSB is the most right-hand bit in a 16-bit word. For a two byte read, only data outputs D7 . . . D0/8 are used. Byte selection is governed by the HBEN input which controls an internal digital multiplexer. This multiplexes the 12-bits of conversion data onto the lower D7 . . . D0/8 outputs (4 MSBs or 8 LSBs) where it can be read in two read cycles. The 4 MSB's always appear on D11 . . . D8 whenever the three-state output drives are turned on.

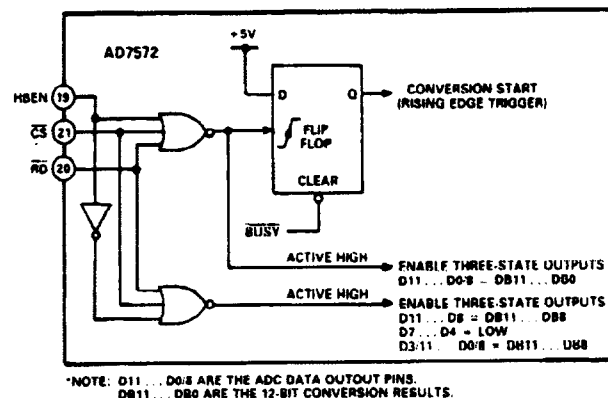

\*NOTE: D11 . . . D0/8 ARE THE ADC DATA OUTPUT PINS.  
DB11 . . . DB0 ARE THE 12-BIT CONVERSION RESULTS.

Figure 16. Internal Logic for Control Inputs  $\overline{CS}$ ,  $\overline{RD}$  and HBEN

### SLOW MEMORY MODE, PARALLEL READ (HBEN = LOW)

Figure 17 and Table I shows the timing diagram and data bus status for Slow Memory Mode, Parallel Read.  $\overline{CS}$  and  $\overline{RD}$  going low triggers a conversion and the AD7572 acknowledges by taking  $\overline{BUSY}$  low. Data from the previous conversion appears on the three state data outputs.  $\overline{BUSY}$  returns high at the end of conversion when the output latches have been updated and the conversion result is placed on data outputs D11 . . . D0/8.

### SLOW MEMORY MODE, TWO BYTE READ

For a two byte read only 8 data outputs D7 . . . D0/8 are used. Conversion start procedure and data output status for the first read operation is identical to Slow Memory Mode, Parallel Read. See Figure 18 timing diagram and Table II data bus status. At the end of conversion the low data byte (DB7 . . . DB0) is read from the ADC. A second READ operation with HBEN high, places the high byte on data outputs D3/11 . . . D0/8 and disables conversion start. Note the 4MSB's appear on data outputs D11 . . . D8 during the two READ operations above.

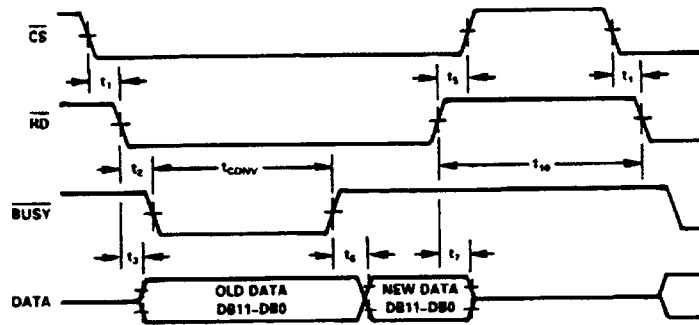

Figure 17. Slow Memory Mode, Parallel Read Timing Diagram

AD7572 Data Outputs	D11	D10	D9	D8	D7	D6	D5	D4	D3/11	D2/10	D1/9	D0/8
Read	DB11	DB10	DB9	DB8	DB7	DB6	DB5	DB4	DB3	DB2	DB1	DB0

Table I. Slow Memory Mode, Parallel Read Data Bus Status

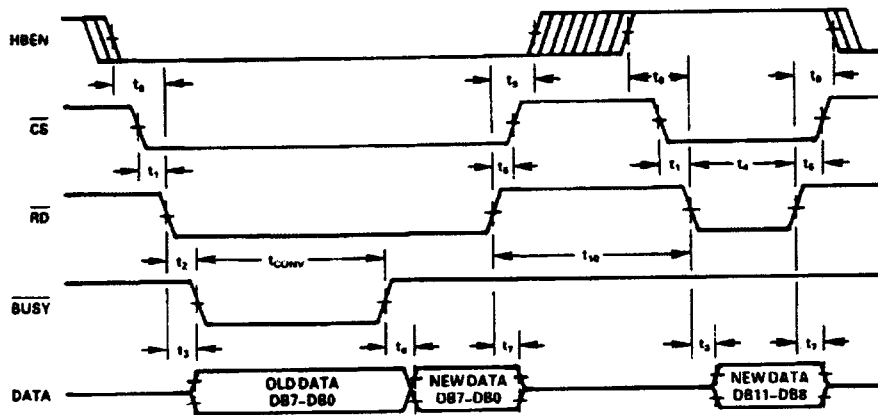

Figure 18. Slow Memory Mode, Two Byte Read Timing Diagram

AD7572 Data Outputs	D7	D6	D5	D4	D3/11	D2/10	D1/9	D0/8
First Read	DB7	DB6	DB5	DB4	DB3	DB2	DB1	DB0
Second Read	LOW	LOW	LOW	LOW	DB11	DB10	DB9	DB8

Table II. Slow Memory Mode, Two Byte Read Data Bus Status

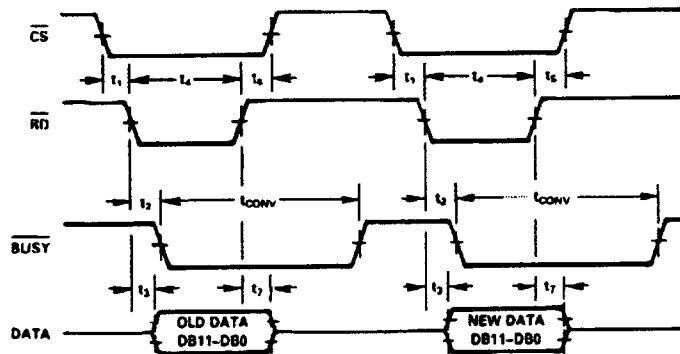

Figure 19. ROM Mode, Parallel Read Timing Diagram

AD7572 Data Outputs	D11	D10	D9	D8	D7	D6	D5	D4	D3/11	D2/10	D1/9	D0/8
First Read (Old Data)	DB11	DB10	DB9	DB8	DB7	DB6	DB5	DB4	DB3	DB2	DB1	DB0
Second Read	DB11	DB10	DB9	DB8	DB7	DB6	DB5	DB4	DB3	DB2	DB1	DB0

Table III. ROM Mode, Parallel Read Data Bus Status

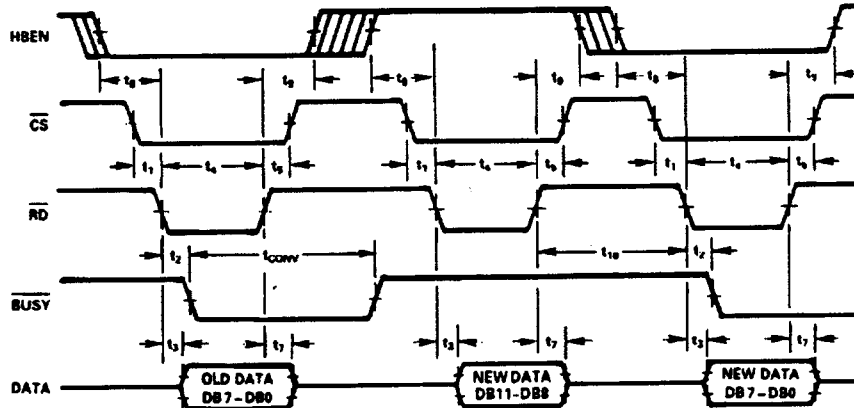

Figure 20. ROM Mode, Two Byte Read Timing Diagram

AD7572 Data Outputs	D7	D6	D5	D4	D3/11	D2/10	D1/9	D0/8
First Read (Old Data)	DB7	DB6	DB5	DB4	DB3	DB2	DB1	DB0
Second Read	LOW	LOW	LOW	LOW	DB11	DB10	DB9	DB8
Third Read	DB7	DB6	DB5	DB4	DB3	DB2	DB1	DB0

Table IV. ROM Mode, Two Byte Read Data Bus Status

**ROM MODE, PARALLEL READ (HBEN = LOW)**

The ROM Mode avoids placing a microprocessor into a wait state. A conversion is started with a READ operation and the 12-bits of data from the previous conversion is available on data outputs D11 . . . D0/8 (see Figure 19 and Table III). This data may be disregarded if not required. A second READ operation reads the new data (DB11 . . . DB0) and starts another conversion. A delay at least as long as the AD7572 conversion time must be allowed between READ operations.

**ROM MODE, TWO BYTE READ**

As previously mentioned for a two byte read, only data outputs D7 . . . D0/8 are used. Conversion is started in the normal way with a READ operation and the data output status is the same as the ROM Mode, Parallel Read. See Figure 20 timing diagram and Table IV data bus status. Two more READ operations are required to access the new conversion result. A delay equal to the AD7572 conversion time must be allowed between conversion start and the second data READ operation. The second READ operation, with HBEN high, disables conversion start and places the high byte (4MSBs) on data outputs D3/11 . . . D0/8. A third READ operation accesses the low data byte (DB7 . . . DB0) and starts another conversion. The 4MSB's appear on data outputs D11 . . . D8 during all three read operations above.

**MICROPROCESSOR INTERFACING**

The AD7572 is designed to interface with microprocessors as a memory mapped device. The CS and RD control inputs are common to all peripheral memory interfacing. The HBEN input serves as a data byte select for 8-bit processors and is normally connected to the microprocessor address bus.

**MC68000 Microprocessor**

Figure 21 shows a typical interface for the 68000. The AD7572 is operating in the Slow Memory Mode. Assuming the AD7572 is located at address C000, then the following single 16-bit MOVE instruction both starts a conversion and reads the conversion result.

```
Move.W $C000,D0
```

At the beginning of the instruction cycle when the ADC address is selected, BUSY and CS assert DTACK, so that the 68000 is forced into a WAIT state. At the end of conversion BUSY returns high and the conversion result is placed in the D0 register of the UP.

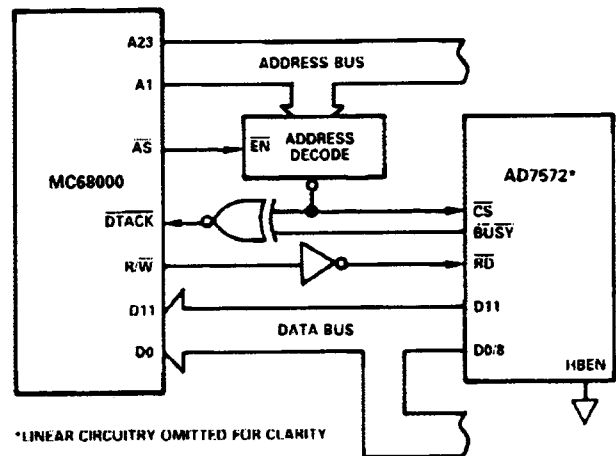

Figure 21. AD7572 - MC68000 Interface



**OUTLINE DIMENSIONS**

Dimensions shown in inches and (mm).

**24-Pin Plastic (Suffix N)**

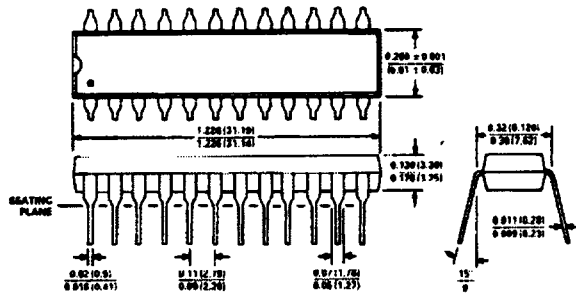

- NOTES  
 1. LEAD NO. 1 IDENTIFIED BY DOT OR NOTCH.  
 2. PLASTIC LEADS WILL BE EITHER SOLDER DIPPED OR FIN/LEAD PLATED IN ACCORDANCE WITH MIL-M-38510 REQUIREMENTS.

**24-Pin Ceramic (Suffix Q)**

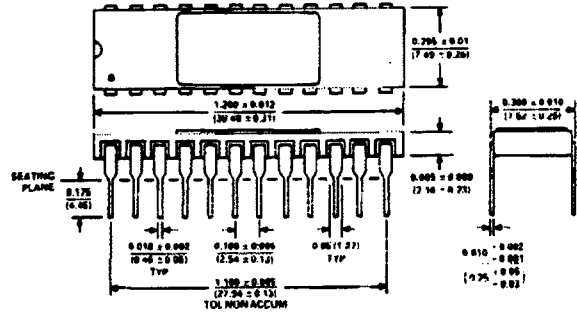

- NOTES  
 1. LEAD NO. 1 IDENTIFIED BY DOT OR NOTCH.  
 2. CERAMIC DIP LEADS WILL BE EITHER GOLD OR TIN PLATED IN ACCORDANCE WITH MIL-M-38510 REQUIREMENTS.  
 3. METAL LEAD IS CONNECTED TO GND.

**24-Pin Cerdip (Suffix Q)**

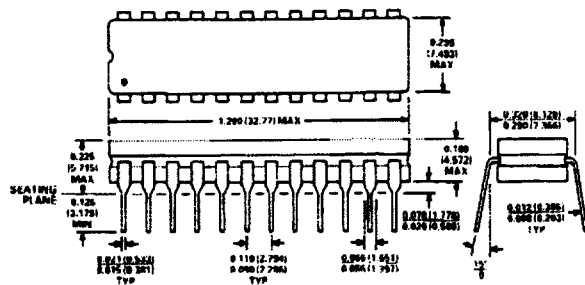

- NOTES  
 1. LEAD NO. 1 IDENTIFIED BY DOT OR NOTCH.  
 2. CERDIP LEADS WILL BE EITHER TIN PLATED OR SOLDER DIPPED IN ACCORDANCE WITH MIL-M-38510 REQUIREMENTS.

**28-Terminal LCCC (Suffix E)**

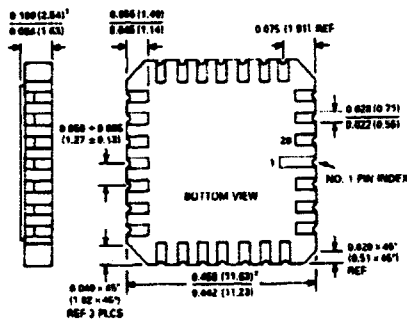

- NOTES  
 1. THIS DIMENSION CONTROLS THE OVERALL PACKAGE THICKNESS  
 2. APPLIES TO ALL FOUR SIDES  
 ALL TERMINALS ARE GOLD PLATED.

**28-Terminal PLCC (Suffix P)**

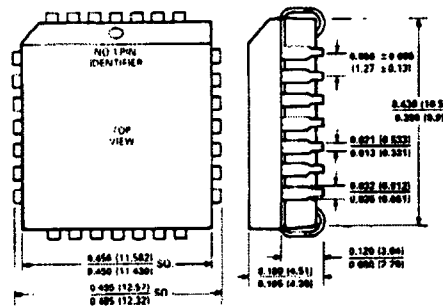



LittleDiode supplies new, hard to find or obsolete electronic components and semiconductors all over the world.

With over two million different components listed you are sure to find the part you need.

Feel free to visit us today at our online store:

[LittleDiode.com](http://LittleDiode.com)

Looking forward to providing you with the best possible service.