

### FEATURES

- Dual IF Inputs, 70 MHz–250 MHz**
  - Diversity or Two Independent IF Signals
  - Separate Attenuation Paths
- Oversample RF Channels**
  - 20 MSPS on a Single Carrier
  - 10 MSPS/Channel in Diversity Mode
- Total Signal Range 90+ dB**
  - 30 dB from Automatic Gain-Ranging (AGC)
  - 60 dB from A/D Converter
  - Range >100 dB After Processing Gain
- Digital Outputs**
  - 11-Bit ADC Word
  - 3-Bit RSSI Word
  - 2× Clock, A/B Indicator
- Single 5 V Power Supply**
  - Output DVCC 3.3 V or 5 V
- 775 mW Power Dissipation**

### APPLICATIONS

- Communications Receivers
- PCS/Cellular Base Stations
  - GSM, CDMA, TDMA
- Wireless Local Loop, Fixed Access

### PRODUCT DESCRIPTION

The AD6600 mixed-signal receiver chip directly samples signals at analog input frequencies up to 250 MHz. The device includes

two input channels, each with 1 GHz input amplifiers and 30 dB of automatic gain-ranging circuitry. Both channels are sampled with a 450 MHz track-and-hold followed by an 11-bit, 20 MSPS analog-to-digital converter. Digital RSSI outputs, an A/B channel indicator, a 2× Clock output, references, and control circuitry are all on-chip. Digital output signals are two's complement, CMOS-compatible and interface directly to 3.3 V or 5 V digital processing chips.

The primary use for the dual analog input structure is sampling both antennas in a two-antenna diversity receiver. However, Channels A and B may also be used to sample two independent IF signals. Diversity, or dual-channel mode, is limited to 10 MSPS per channel. In single-channel mode, the full clock rate of 20 MSPS may be applied to a single carrier.

The AD6600 may be used as a stand-alone sampling chip, or it may be combined with the AD6620 Digital Receive Signal Processor. The AD6620 provides 10 dB–25 dB of additional processing gain before passing data to a fixed- or floating-point DSP.

Driving the AD6600 is simplified by using the AD6630 differential IF amplifier. The AD6630 is easily matched to inexpensive SAW filters from 70 MHz to 250 MHz.

Designed specifically for cellular/PCS receivers, the AD6600 supports GSM, IS-136, CDMA and Wireless LANs, as well as proprietary air interfaces used in WLL/fixed-access systems.

Units are available in plastic, surface-mount packages (44-lead LQFP) and specified over the industrial temperature range (–40°C to +85°C).

### FUNCTIONAL BLOCK DIAGRAM

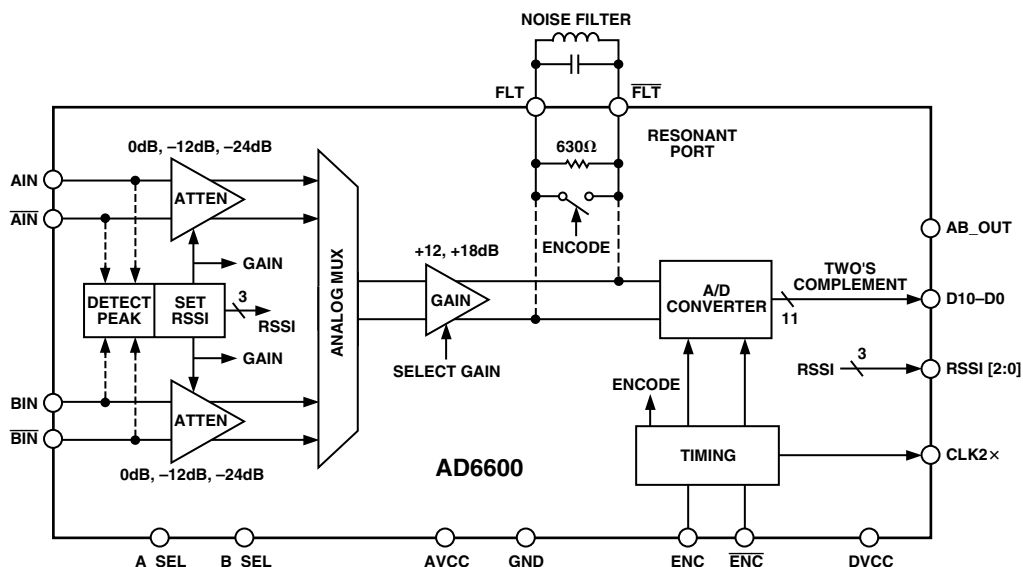

REV. 0

Information furnished by Analog Devices is believed to be accurate and reliable. However, no responsibility is assumed by Analog Devices for its use, nor for any infringements of patents or other rights of third parties which may result from its use. No license is granted by implication or otherwise under any patent or patent rights of Analog Devices.

# AD6600—SPECIFICATIONS

## DC SPECIFICATIONS (AVCC = 5 V, DVCC = 3.3 V; T<sub>MIN</sub> = -40°C, T<sub>MAX</sub> = +85°C unless otherwise noted.)

Parameter	Temp	Test Level	AD6600AST			Unit
			Min	Typ	Max	
<b>ANALOG INPUTS (AIN, AIN<math>\overline{\text{BIN}}</math>, BIN<math>\overline{\text{BIN}}</math>)</b>						
Differential Analog Input Voltage Range <sup>1</sup>	Full	V		2.0		V p-p
Differential Analog Input Resistance <sup>2</sup>	Full	IV	160	200	240	$\Omega$
Differential Analog Input Capacitance	25°C	V		1.5		pF
<b>PEAK DETECTOR (Internal), RSSI</b>						
Resolution				3		Bits
RSSI Gain Step	Full	V		6		dB
RSSI Hysteresis <sup>3</sup>	Full	V		6		dB
<b>RESONANT PORT (FLT, FLT<math>\overline{\text{FLT}}</math>)</b>						
Differential Port Resistance	Full	V		630		$\Omega$
Differential Port Capacitance	Full	V		1.75		pF
<b>A/D CONVERTER</b>						
Resolution	Full	IV		11		Bits
<b>ENCODE INPUTS (ENC, ENC<math>\overline{\text{ENC}}</math>)</b>						
Differential Input Voltage (AC-Coupled) <sup>4</sup>	Full	IV	0.4			V p-p
Differential Input Resistance	25°C	V		11		k $\Omega$
Differential Input Capacitance	25°C	V		2.5		pF
<b>A/B MODE INPUTS (A_SEL, B_SEL)<sup>5</sup></b>						
Input High Voltage Range	Full	IV	4.75		5.25	V
Input Low Voltage Range	Full	IV	0.0		0.5	V
<b>POWER SUPPLY</b>						
Supply Voltages						
AVCC	Full	II	4.75	5.0	5.25	V
DVCC	Full	IV	3.0	3.3	5.25	V
Supply Current						
I <sub>AVCC</sub> (AVCC = 5.0 V)	Full	II		145	182	mA
I <sub>DVCC</sub> (DVCC = 3.3 V)	Full	II		15	20	mA
<b>POWER CONSUMPTION<sup>6</sup></b>						
	Full	II		775	976	mW

### NOTES

<sup>1</sup>Analog Input Range is a function of input frequency. See ac specifications for 70 MHz–250 MHz inputs.

<sup>2</sup>Analog Input Impedance is a function of input frequency. See ac specifications for 70 MHz–450 MHz inputs.

<sup>3</sup>Six dB of digital hysteresis is used to eliminate level uncertainty at the RSSI threshold points due to noise and amplitude variations.

<sup>4</sup>Encode inputs should be ac-coupled and driven differentially. See Encoding the AD6600 for details.

<sup>5</sup>A\_SEL and B\_SEL should be tied directly to ground or AVCC.

<sup>6</sup>Maximum power consumption is computed as maximum current at nominal supplies.

Specifications subject to change without notice.

## DIGITAL SPECIFICATIONS (AVCC = 5 V, DVCC = 3.3 V; T<sub>MIN</sub> = -40°C, T<sub>MAX</sub> = +85°C unless otherwise noted.)

Parameter	Temp	Test Level	AD6600AST			Unit
			Min	Typ	Max	
<b>LOGIC OUTPUTS (D10–D0, AB_OUT, RSSI2–0)<sup>1</sup></b>						
Logic Compatibility				CMOS		
Logic “1” Voltage (DVCC = 3.3 V)	Full	II	2.8	DVCC – 0.2		V
Logic “0” Voltage (DVCC = 3.3 V)	Full	II		0.2	0.5	V
Logic “1” Voltage (DVCC = 5.0 V)	Full	IV	4.0	DVCC – 0.35		V
Logic “0” Voltage (DVCC = 5.0 V)	Full	IV		0.35	0.5	V
Output Coding (D10–D0)				Two’s Complement		
<b>CLK2<math>\times</math> OUTPUT<sup>1, 2</sup></b>						
Logic “1” Voltage (DVCC = 3.3 V)	Full	II	2.8	DVCC – 0.2		V
Logic “0” Voltage (DVCC = 3.3 V)	Full	II		0.2	0.5	V
Logic “1” Voltage (DVCC = 5.0 V)	Full	IV	4.0	DVCC – 0.3		V
Logic “0” Voltage (DVCC = 5.0 V)	Full	IV		0.35	0.5	V

### NOTES

<sup>1</sup>Digital output load is one LCX gate.

<sup>2</sup>CLK2 $\times$  output voltage levels, high and low, tested at switching rate of 10 MHz.

Specifications subject to change without notice.

TIMING REQUIREMENTS AND SWITCHING SPECIFICATIONS<sup>1</sup>(AVCC = 5 V, DVCC = 3.3 V; ENC and  $\overline{\text{ENC}}$  = 20 MSPS; T<sub>MIN</sub> = -40°C, T<sub>MAX</sub> = +85°C unless otherwise noted.)

Parameter	Name	Temp	Test Level	AD6600AST			Unit
				Min	Typ	Max	
<b>A/D CONVERTER</b>							
Conversion Rate	f <sub>ENC</sub>	Full	II	20	1/(t <sub>ENC</sub> )	6	MSPS
Maximum Conversion Rate		Full	IV				MSPS
Minimum Conversion Rate		Full	V		0.3		MSPS
Aperture Uncertainty	t <sub>j</sub>	25°C					ps rms
<b>ENCODE INPUTS (ENC, <math>\overline{\text{ENC}}</math>)<sup>2</sup></b>							
Period	t <sub>ENC</sub>	Full	II	50			ns
Pulsewidth High <sup>3</sup>	t <sub>ENCH</sub>	Full	IV	20			ns
Pulsewidth Low <sup>4</sup>	t <sub>ENCL</sub>	Full	IV	20			ns
<b>2× CLOCK OUTPUT (CLK2×)<sup>5</sup></b>							
Output Frequency					2× f <sub>ENC</sub>		MSPS
Output Period <sup>6</sup>	t <sub>CLK2×,1</sub>	Full	V		t <sub>ENCL</sub>		ns
	t <sub>CLK2×,2</sub>	Full	V		t <sub>ENCH</sub>		ns
CLK2× Pulsewidth Low <sup>6</sup>	t <sub>CLK2×,L</sub>	Full	V		t <sub>ENCH</sub> /2		ns
Output Risetime <sup>7</sup>		Full	V		3		ns
Output Faltime <sup>7</sup>		Full	V		2.6		ns
<b>OUTPUT RISE/FALL TIMES<sup>8</sup></b>							
Output Risetime (D10:D0, RSSI2:0)		Full	V		8		ns
Output Faltime (D10:D0, RSSI2:0)		Full	V		8.4		ns
Output Risetime (AB_OUT)		Full	V		6		ns
Output Faltime (AB_OUT)		Full	V		6.2		ns

## NOTES

<sup>1</sup>See AD6600 Timing Diagrams.<sup>2</sup>All switching specifications tested by driving ENC and  $\overline{\text{ENC}}$  differentially.<sup>3</sup>Several timing specifications are a function of Encode high time, t<sub>ENCH</sub>; these specifications are shown in the data tables and timing diagrams. Encode duty cycle should be kept as close to 50% as possible.<sup>4</sup>Encode pulse low directly affects the amount of settling time available at FLT resonant port. See External Analog (Resonant) Filter section for details.<sup>5</sup>The 2× Clock is generated internally, therefore some specifications are functions of encode period and duty cycle. All timing measurements to or from CLK2× are referenced to 2.0 V crossing.<sup>6</sup>This specification IS a function of Encode period and duty cycle; reference timing diagrams Figure 8.<sup>7</sup>Output rise time is measured from 20% point to 80% point of total CLK2× voltage swing; output fall time is measured from 80% point to 20% point of total CLK2× voltage swing.<sup>8</sup>Output rise time is measured from 20% point to 80% point of total data voltage swing; output fall time is measured from 80% point to 20% point of total data voltage swing. All outputs specified with 10 pF load.

Specifications subject to change without notice.

# AD6600—SPECIFICATIONS

## TIMING REQUIREMENTS AND SWITCHING SPECIFICATIONS<sup>1, 2</sup>

(AVCC = 5 V, DVCC = 3.3 V; ENC and  $\overline{\text{ENC}}$  = 20 MSPS, Duty Cycle = 50%; T<sub>MIN</sub> = -40°C, T<sub>MAX</sub> = +85°C unless otherwise noted.)

Parameter	Name	Temp	Test Level	AD6600AST			Unit
				Min	Typ	Max	
ENCODE/CLK2× Encode Rising to CLK2× Falling <sup>3</sup> Encode Rising to CLK2× Rising <sup>4</sup> @ Encode = 13 MSPS, 50% Duty Cycle @ Encode = 20 MSPS, 50% Duty Cycle	t <sub>CF</sub>	Full	IV	6.5	8.0	9.5	ns
	t <sub>CR</sub>	Full	IV		t <sub>CF</sub> + (t <sub>ENCH</sub> )/2		ns
		Full	IV	25.7	27.2	28.7	ns
		Full	IV	19.0	20.5	22.0	ns
CLK2×/DATA (D10:0, RSSI2:0) <sup>5</sup> CLK2× to DATA Rising Low Delay <sup>3</sup> CLK2× to DATA Hold Time <sup>3</sup> CLK2× to DATA Falling Low <sup>3, 6</sup>  CLK2× to DATA Setup Time <sup>4</sup> @ Encode = 13 MSPS, 50% Duty Cycle @ Encode = 20 MSPS, 50% Duty Cycle <sup>6</sup>	t <sub>2×_DRL</sub>	Full	IV	3.0	6.5		ns
	t <sub>H_D2×</sub>	Full	IV	3.0	6.5		ns
	t <sub>2×_DFL</sub>	25°C	IV	10.0	15.0	20.0	ns
		Full	IV	11.0	15.5	22.0	ns
	t <sub>S_D2×</sub>	Full	IV		t <sub>ENCH</sub> - t <sub>2×_DFL</sub>		ns
		Full	IV	16.5	23.0		ns
		25°C	IV	5.0	10.0		ns
		Full	IV	3.0	9.5		ns
CLK2×/AB_OUT <sup>5</sup> CLK2× to AB_OUT Rising Low Delay <sup>3</sup> CLK2× to AB_OUT Hold Time <sup>3</sup> CLK2× to AB_OUT Falling Low Delay <sup>3, 6</sup>  CLK2× to AB_OUT Setup Time <sup>4</sup> @ Encode = 13 MSPS, 50% Duty Cycle @ Encode = 20 MSPS, 50% Duty Cycle <sup>6</sup>	t <sub>2×_ARL</sub>	Full	IV	7.0	11.0		ns
	t <sub>H_A2×</sub>	Full	IV	7.0	11.0		ns
	t <sub>2×_AFL</sub>	25°C	IV	12.0	18.0	23.0	ns
		Full	IV	10.7	19.0	26.0	ns
	t <sub>S_A2×</sub>	Full	IV		t <sub>ENCH</sub> - t <sub>2×_AFL</sub>		ns
		Full	IV	12.5	19.5		ns
		25°C	IV	2.0	7.0		ns
		Full	IV	-1.0	6.0		ns
ENCODE/DATA (D10:0, RSSI2:0) ENCODE to DATA Rising Low Delay <sup>4</sup> ENCODE to DATA Hold Time <sup>4</sup> @ Encode = 13 MSPS, 50% Duty Cycle @ Encode = 20 MSPS, 50% Duty Cycle ENCODE to DATA Falling Low Delay <sup>4</sup> ENCODE to DATA Delay (Setup) <sup>4</sup> @ Encode = 13 MSPS, 50% Duty Cycle @ Encode = 20 MSPS, 50% Duty Cycle <sup>6</sup>	t <sub>EN_DRL</sub>	Full	IV		t <sub>CR</sub> + t <sub>2×_DRL</sub>		ns
	t <sub>H_DEN</sub>	Full	IV		t <sub>EN_DRL</sub>		ns
		Full	IV	28.7	33.7		ns
		Full	IV	22.0	27.0		ns
	t <sub>EN_DFL</sub>	Full	IV		t <sub>CR</sub> + t <sub>2×_DFL</sub>		ns
	t <sub>S_DEN</sub>	Full	IV		t <sub>ENC</sub> - t <sub>EN_DFL</sub>		ns
		Full	IV	26.2	34.2		ns
		25°C	IV	8.0	14.5		ns
	Full	IV	6.0	14.0		ns	
ENCODE/AB_OUT ENCODE to AB_OUT Rising Low Delay <sup>4</sup> ENCODE to AB_OUT Delay (Hold) <sup>4</sup> @ Encode = 13 MSPS, 50% Duty Cycle @ Encode = 20 MSPS, 50% Duty Cycle ENCODE to AB_OUT Falling Low Delay <sup>4</sup> ENCODE to AB_OUT Delay (Setup) <sup>4</sup> @ Encode = 13 MSPS, 50% Duty Cycle @ Encode = 20 MSPS, 50% Duty Cycle <sup>6</sup>	t <sub>EN_ARL</sub>	Full	IV		t <sub>CR</sub> + t <sub>2×_ARL</sub>		ns
	t <sub>H_AEN</sub>	Full	IV		t <sub>EN_ARL</sub>		ns
		Full	IV	32.7	38.2		ns
		Full	IV	26.0	31.5		ns
	t <sub>EN_AFL</sub>	Full	IV		t <sub>CR</sub> + t <sub>2×_AFL</sub>		ns
	t <sub>S_AEN</sub>	Full	IV		t <sub>ENC</sub> - t <sub>EN_AFL</sub>		ns
		Full	IV	22.2	30.7		ns
		25°C	IV	5.0	11.5		ns
		Full	IV	2.0	10.5		ns

### NOTES

<sup>1</sup>See AD6600 Timing Diagrams.

<sup>2</sup>All switching specifications tested by driving ENC and  $\overline{\text{ENC}}$  differentially.

<sup>3</sup>This specification IS NOT a function of Encode period and duty cycle.

<sup>4</sup>This specification IS a function of Encode period and duty cycle.

<sup>5</sup>CLK2× referenced to 2.0 V crossing; digital output levels referenced to 0.8 V and 2.0 V crossings; all outputs with 10 pF load.

<sup>6</sup>For these particular specifications, the 25°C specification is valid from 25°C to 85°C. The Full temperature specification includes cold temperature extreme and covers the entire range, -40°C to +85°C.

Specifications subject to change without notice.

# AC SPECIFICATIONS

(AVCC = 5 V, DVCC = 3.3 V; ENC and  $\overline{\text{ENC}}$  = 20 MSPS, Duty Cycle = 50%; T<sub>MIN</sub> = -40°C, T<sub>MAX</sub> = +85°C unless otherwise noted.)

Parameter	Temp	Test Level	AD6600AST			Unit
			Min	Typ	Max	
<b>ANALOG INPUTS<sup>1</sup></b>						
Analog Input 3 dB Bandwidth <sup>2</sup>	Full	V		450		MHz
Differential Analog Input Voltage Range						
70 MHz	Full	V		2.45		V p-p
150 MHz	Full	V		2.57		V p-p
200 MHz	Full	V		2.62		V p-p
250 MHz	Full	V		2.86		V p-p
Differential Analog Input Impedance <sup>3</sup>						
70 MHz	25°C	V		197-j24		Ω
150 MHz	25°C	V		188-j48		Ω
200 MHz	25°C	V		175-j57		Ω
250 MHz	25°C	V		161-j67		Ω
300 MHz	25°C	V		151-j73		Ω
350 MHz	25°C	V		140-j80		Ω
400 MHz	25°C	V		141-j75		Ω
450 MHz	25°C	V		173-j107		Ω
Full-Scale Input Power						
70 MHz	Full	V		5.8		dBm
150 MHz	Full	V		6.3		dBm
200 MHz	Full	V		6.7		dBm
250 MHz	Full	V		7.7		dBm
Full-Scale Gain Tolerance <sup>4</sup>						
70 MHz–250 MHz	Full	V		±0.5		dB
200 MHz <sup>5</sup>	25°C	I	-1.0	±0.1	+1.0	dB
Gain Error						
AIN = 200 MHz						
@ -76 dBFS	25°C	I	-1.5		+1.5	dB
Gain Matching (Input A:B)						
70 MHz–250 MHz	Full	V		±0.1		dB
200 MHz	Full	II	-0.5	±0.05	+0.5	dB
Range-to-Range Gain Tolerance						
70 MHz–250 MHz	Full	V		±0.1		dB
Range-to-Range Phase Tolerance						
70 MHz	Full	V		0.2		Degree
250 MHz	Full	V		0.5		Degree
Channel Isolation <sup>6</sup>						
70 MHz–250 MHz	Full	IV	45	50		dB
Noise <sup>7</sup>						
Minimum Attenuation Level	Full	V		34		μV rms
Maximum Attenuation Level	Full	V		869		μV rms
Attenuator 3OIP <sup>8</sup>	Full	V		+33		dBm
Signal-to-Noise Ratio (SNR) <sup>9, 10, 11</sup>						
AIN = 70 MHz						
@ -1 dBFS	25°C	IV	55	59		dB
@ -6 dBFS	25°C	V		54.5		dB
@ -10 dBFS	25°C	IV	45	49		dB
@ -12 dBFS to -42 dBFS	25°C	IV	41	48 ±6		dB
@ -54 dBFS	25°C	IV	31	34		dB
AIN = 150 MHz						
@ -1 dBFS	25°C	IV	55	58		dB
@ -6 dBFS	25°C	V		54		dB
@ -10 dBFS	25°C	IV	45	49		dB
@ -12 dBFS to -42 dBFS	25°C	IV	41	48 ±6		dB
@ -54 dBFS	25°C	IV	31	34		dB

# AD6600—SPECIFICATIONS

## AC SPECIFICATIONS (continued)

Parameter	Temp	Test Level	AD6600AST			Unit
			Min	Typ	Max	
<b>ANALOG INPUTS (Continued)</b>						
Signal-to-Noise Ratio (Continued)						
AIN = 200 MHz						
@ -1 dBFS	25°C	I	55	57.5		dB
@ -6 dBFS	25°C	V		53.5		dB
@ -10 dBFS	25°C	I	45	49		dB
@ -12 dBFS to -42 dBFS	25°C	I	40.5	48 ± 6		dB
@ -54 dBFS	25°C	I	31	34		dB
AIN = 250 MHz						
@ -1 dBFS	25°C	IV	52	56		dB
@ -6 dBFS	25°C	V		53.5		dB
@ -10 dBFS	25°C	IV	43	49		dB
@ -12 dBFS to -42 dBFS	25°C	IV	40	48 ± 6		dB
@ -54 dBFS	25°C	IV	30	34		dB
<b>SECOND HARMONIC</b>						
AIN = 70 MHz						
@ -1 dBFS	Full	V		69		dBc
@ -6 dBFS	Full	V		68		dBc
@ -12 dBFS to -42 dBFS	Full	V		68 ± 6		dBc
AIN = 150 MHz						
@ -1 dBFS	Full	V		60		dBc
@ -6 dBFS	Full	V		59		dBc
@ -12 dBFS to -42 dBFS	Full	V		67 ± 6		dBc
AIN = 200 MHz <sup>9, 10, 11</sup>						
@ -1 dBFS	25°C	I	50	60		dBc
@ -6 dBFS	Full	V		56		dBc
@ -10 dBFS	25°C	I	48	55		dBc
@ -12 dBFS to -42 dBFS	Full	V		65 ± 6		dBc
@ -54 dBFS	Full	V		50		dBc
AIN = 250 MHz						
@ -1 dBFS	Full	V		54		dBc
@ -6 dBFS	Full	V		62		dBc
@ -12 dBFS to -42 dBFS	Full	V		65 ± 6		dBc
<b>THIRD HARMONIC</b>						
AIN = 70 MHz						
@ -1 dBFS	Full	V		77		dBc
@ -6 dBFS	Full	V		76		dBc
@ -12 dBFS to -42 dBFS	Full	V		67 ± 6		dBc
AIN = 150 MHz						
@ -1 dBFS	Full	V		65		dBc
@ -6 dBFS	Full	V		70		dBc
@ -12 dBFS to -42 dBFS	Full	V		66 ± 6		dBc
AIN = 200 MHz <sup>9, 10, 11</sup>						
@ -1 dBFS	25°C	I	50	55		dBc
@ -6 dBFS	Full	V		58		dBc
@ -10 dBFS	25°C	I	55	66		dBc
@ -12 dBFS to -42 dBFS	Full	V		65 ± 6		dBc
@ -54 dBFS	Full	V		62		dBc
AIN = 250 MHz						
@ -1 dBFS	Full	V		50		dBc
@ -6 dBFS	Full	V		56		dBc
@ -12 dBFS to -42 dBFS	Full	V		65 ± 6		dBc
AIN = 70 MHz–250 MHz						
@ -75 dBFS	Full	IV	28	35		dBc

## AC SPECIFICATIONS (continued)

Parameter	Temp	Test Level	AD6600AST			Unit
			Min	Typ	Max	
WORST OTHER SPUR (4th or Higher)						
AIN = 70 MHz						
@ -1 dBFS	Full	V		74.5		dBc
@ -6 dBFS	Full	V		71		dBc
@ -12 dBFS to -42 dBFS	Full	V		68 ±6		dBc
AIN = 150 MHz						
@ -1 dBFS	Full	V		67		dBc
@ -6 dBFS	Full	V		65		dBc
@ -12 dBFS to -42 dBFS	Full	V		67 ±6		dBc
AIN = 200 MHz						
@ -1 dBFS	25°C	I	60	67		dBc
@ -6 dBFS	Full	V		66		dBc
@ -10 dBFS	25°C	I	55	66		dBc
@ -12 dBFS to -42 dBFS	Full	V		65 ±6		dBc
AIN = 250 MHz						
@ -1 dBFS	Full	V		66.5		dBc
@ -6 dBFS	Full	V		65		dBc
@ -12 dBFS to -42 dBFS	Full	V		65 ±6		dBc

## NOTES

<sup>1</sup>AIN,  $\overline{\text{AIN}}/\overline{\text{BIN}}$ ,  $\overline{\text{BIN}}$ : The AD6600 analog inputs are unconditionally stable and guarantee proper operation over the 70 MHz–250 MHz specified operating range.

Circuit board layout is critical on this device, and proper PCB layout must be employed to achieve specified results.

<sup>2</sup>Analog Input 3 dB Bandwidth is determined by internal track-and-hold. The front-end attenuators have a bandwidth of 1 GHz.

<sup>3</sup>Measured real and imaginary values using Network Analyzer.

<sup>4</sup>Full-scale gain tolerance is the typical variation in gain at a given IF input frequency. The nominal value for full-scale input power is a function of frequency as shown in previous specification.

<sup>5</sup>Full-scale gain tolerance measured at 200 MHz analog input referenced to 6.7 dBm nominal full-scale input power. For the gain measurement test, the input signal level is set to -6 dBFS. Tuning port bandwidth is set to 50 MHz.

<sup>6</sup>Main channel set to full-scale input power. Diversity channel swept from -20 dBFS to -90 dBFS.

<sup>7</sup>Measurement includes thermal and quantization noise at 70 MHz analog input. Tuning port bandwidth is set to 50 MHz.

<sup>8</sup>Test tones at 160.05 MHz and 170.05 MHz.

<sup>9</sup>Measurements at -1 dBFS, -6 dBFS, and -10 dBFS are in highest attenuation mode, RSSI = 101.

<sup>10</sup>Each gain-range is checked at ~3 dB from RSSI trip point (not in hysteresis); nominally -16 dBFS (RSSI = 100), -22 dBFS (RSSI = 011), -28 dBFS (RSSI = 010), -35 dBFS (RSSI = 001).

<sup>11</sup>Measurement at -54 dBFS is in the lowest attenuation mode, RSSI = 000.

Specifications subject to change without notice.

# AD6600

## ABSOLUTE MAXIMUM RATINGS<sup>1</sup>

Parameter	Min	Max	Unit
<b>ELECTRICAL</b>			
AVCC Voltage	0	7	V
DVCC Voltage	0	7	V
Analog Input Voltage <sup>2</sup>	0	AVCC	V
Analog Input Current <sup>2</sup>		25	mA
Digital Input Voltage <sup>3</sup>	0	AVCC	V
Output Current <sup>4</sup>		4	mA
Resonant Port Voltage <sup>5</sup>	0	AVCC	V
<b>ENVIRONMENTAL<sup>6</sup></b>			
Operating Temperature Range (Ambient)	-40	+85	°C
Maximum Junction Temperature		150	°C
Lead Temperature (Soldering, 10 sec)		300	°C
Storage Temperature Range (Ambient)	-65	+150	°C

### NOTES

<sup>1</sup>Absolute maximum ratings are limiting values to be applied individually, and beyond which the serviceability of the circuit may be impaired. Functional operability is not necessarily implied. Exposure to absolute maximum rating conditions for an extended period of time may affect device reliability.

<sup>2</sup>Pins AIN,  $\overline{\text{AIN}}$ , BIN,  $\overline{\text{BIN}}$ .

<sup>3</sup>Pins ENC,  $\overline{\text{ENC}}$ , A\_SEL, B\_SEL.

<sup>4</sup>Pins D10:0, RSSI2:0, AB\_OUT, CLK2x.

<sup>5</sup>Pins FLT,  $\overline{\text{FLT}}$ .

<sup>6</sup>Typical thermal impedance (44-lead LQFP);  $\theta_{JC} = 16^{\circ}\text{C}/\text{W}$ ,  $\theta_{JA} = 55^{\circ}\text{C}/\text{W}$ .

### CAUTION

ESD (electrostatic discharge) sensitive device. Electrostatic charges as high as 4000 V readily accumulate on the human body and test equipment and can discharge without detection. Although the AD6600 features proprietary ESD protection circuitry, permanent damage may occur on devices subjected to high-energy electrostatic discharges. Therefore, proper ESD precautions are recommended to avoid performance degradation or loss of functionality.

## EXPLANATION OF TEST LEVELS

### Test Level

- I. 100% Production Tested.
- II. 100% Production Tested at 25°C and guaranteed by design and characterization at temperature extremes.
- IV. Parameter is guaranteed by design and characterization testing.
- V. Parameter is a typical value only.

## ORDERING GUIDE

Model	Temperature Range	Package Description	Package Option
AD6600AST	-40°C to +85°C (Ambient)	44-Terminal LQFP (Low-Profile Quad Plastic Flatpack)	ST-44
AD6600ST/PCB		Evaluation Board with AD6600AST	



## PIN FUNCTION DESCRIPTIONS

Pin Number	Name	Function
1, 33	DVCC	Digital VCC for Digital Outputs. Can be 3.3 V.
2, 5, 13, 19, 21, 24, 30, 32	GND	Ground.
3	C1	Internal Bias Point. Bypass by 0.01 $\mu$ F to GND.
4, 14, 15, 18, 20, 25, 31	AVCC	5 V Power Supply.
6–8	RSSI[2:0]	RSSI Digital Output Bits.
9, 10	B_SEL, A_SEL	Mode Select Pins for Analog Input Channel A and B Sampling.
11	$\overline{\text{AIN}}$	True Analog Input Channel A.
12	$\overline{\text{AIN}}$	Complementary Analog Input Channel A.
16, 17	$\overline{\text{FLT}}$ , FLT	Resonant Filter Pins for External LC Noise Filter.
22	$\overline{\text{BIN}}$	Complementary Analog Input Channel B.
23	BIN	True Analog Input Channel B.
26	$\overline{\text{ENC}}$	Complementary Encode Input.
27	ENC	True Encode Input.
28	CLK2 $\times$	2 $\times$ Clock Output Used for Clocking Digital Filter Chips.
29	AB_OUT	Digital Output Flag Indicating Whether Output Is Input A (High) or B (Low).
34	D0	Digital Data Output Bit (Least Significant Bit)*
35–43	D1–D9	Digital Data Output Bits*
44	D10	Digital Data Output Bit (Most Significant Bit)*

\*Digital Outputs (D10:D0) in Two's Complement Format.

## PIN CONFIGURATION

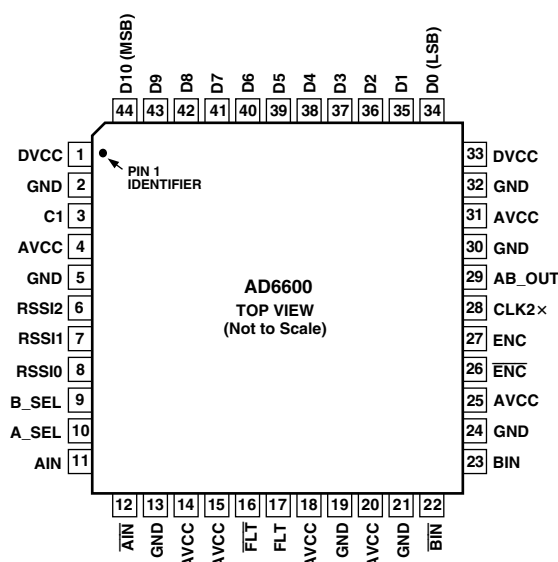

# AD6600

## DEFINITIONS OF SPECIFICATIONS

### Analog Bandwidth

The analog input frequency at which the spectral power of the fundamental frequency (as determined by the FFT analysis) is reduced by 3 dB. The bandwidth is determined by the internal track-and-hold when the filter node is resonated.

### Aperture Delay

The delay between the 50% point of the rising edge of the ENCODE command and the instant at which the analog input is sampled.

### Aperture Uncertainty (Jitter)

The sample-to-sample variation in aperture delay.

### Attenuator 3OIP

The third order intercept point of the front end of the AD6600. It is the point at which the third order products would theoretically intercept the input signal level if the input level could increase without bounds. This is measured using the ADC within the AD6600 while the input is stimulated with dual tones in the minimum attenuation (i.e., maximum gain) range.

### Channel Isolation

The amount of signal leakage from one channel to the next when one channel is driven with a full-scale input, and the other channel is swept from -20 dBFS to -90 dBFS with a frequency offset. The leakage is measured on the side with the smaller signal.

### Differential Analog Input Resistance, Differential Analog Input Capacitance and Differential Analog Input Impedance

The real and complex impedances measured at each analog input port. The resistance is measured statically and the capacitance and differential input impedances are measured with a network analyzer.

### Differential Analog Input Voltage Range

The peak-to-peak differential voltage that must be applied to the converter to generate a full-scale response. Peak differential voltage is computed by observing the voltage on a single pin and subtracting the voltage from the other pin, which is 180 degrees out of phase. Peak-to-peak differential is computed by rotating the inputs phase 180 degrees and taking the peak measurement again. The difference is then computed between both peak measurements.

### Differential Nonlinearity

The deviation of any code width from an ideal 1 LSB step.

### Differential Resonant Port Resistance

The resistance shunted across the resonant port (nominally 630 Ω). Used to determine the filter bandwidth and gain of that stage.

### Encode Pulsewidth/Duty Cycle

Pulsewidth high is the minimum amount of time that the ENCODE pulse should be left in logic “1” state to achieve rated performance; pulsewidth low is the minimum time ENCODE pulse should be left in low state. See timing implications of changing  $t_{ENCH}$  in text. At a given clock rate, these specifications define an acceptable Encode duty cycle.

### Full-Scale Gain Tolerance

Unit-to-unit variation in full-scale input power.

### Full-Scale Input Power

Expressed in dBm. Computed using the following equation:

$$Power_{FULL\ SCALE} = 10 \log \left( \frac{V_{FULL\ SCALE\ rms}^2}{\frac{Z_{INPUT}}{0.001}} \right)$$

### Gain Matching (Input A:B)

Variation in full-scale power between A and B inputs.

### Harmonic Distortion, 2nd

The ratio of the rms signal amplitude to the rms value of the second harmonic component, reported in dBc.

### Harmonic Distortion, 3rd

The ratio of the rms signal amplitude to the rms value of the third harmonic component, reported in dBc.

### Integral Nonlinearity

The deviation of the transfer function from a reference line measured in fractions of 1 LSB using a “best straight line” determined by a least square curve fit.

### Minimum Conversion Rate

The encode rate at which the SNR of the lowest analog signal frequency drops by no more than 3 dB below the guaranteed limit.

### Maximum Conversion Rate

The encode rate at which parametric testing is performed.

### Noise (For Any Range Within the ADC)

$$V_{NOISE} = \sqrt{Z \times 0.001 \times 10^{\left( \frac{FS_{dBm} - SNR_{dBc} - Signal_{dBFS}}{10} \right)}}$$

where:

$Z$  is the input impedance,

$FS$  is the full-scale of the device for the frequency in question,

$SNR$  is the value for the particular input level,

$Signal$  is the signal level within the ADC reported in dB below full scale. This value includes both thermal and quantization noise.

### Range-Range Gain Tolerance

The gain error in the RSSI attenuator ladder from one range to the next.

### Range-Range Phase Tolerance

The phase error in the RSSI attenuator ladder from one range to the next.

### Differential Resonant Port Capacitance

The capacitance between the two resonant pins. Used to determine filter bandwidth and resonant frequency.

**RSSI Gain Step**

The input amplitude span between taps of the RSSI (received signal strength) attenuator ladder. Ideally each stage should span 6 dB of input power.

**RSSI Hysteresis**

The amount of movement in the RSSI switch points, depending on the direction of approach. Hysteresis prevents unnecessary RSSI toggling when input signal power is near a threshold.

**Signal-to-Noise Ratio (Without Harmonics)**

The ratio of the rms signal amplitude (set at 1 dB below full scale) to the rms value of the sum of all other spectral components, excluding the first five harmonics and dc.

**Worst Other Spur**

The ratio of the rms signal amplitude to the rms value of the worst spurious component (excluding the second and third harmonic) reported in dBc.

**AD6600 TRANSFER FUNCTION**

Figure 1. SNR vs. Input Power

# AD6600

## EQUIVALENT CIRCUITS

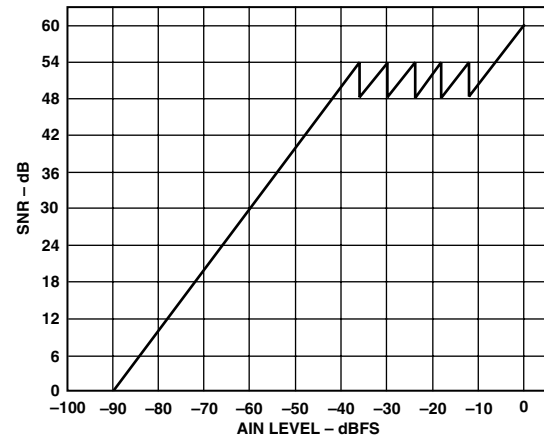
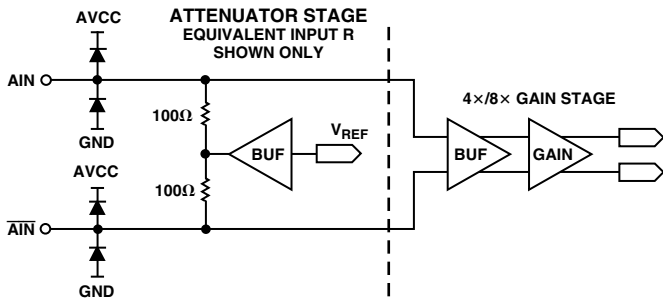

Figure 2. Analog Input Stage (Channel A Shown; Channel B Is Equivalent)

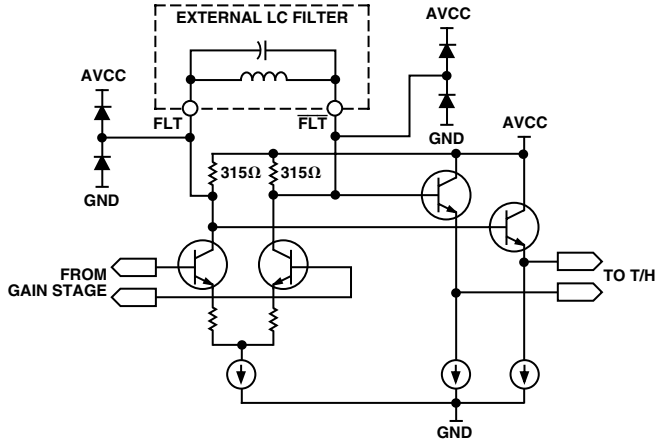

Figure 5. Resonant (LC Noise Filter) Port

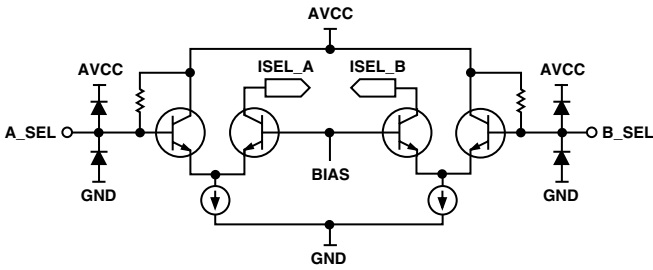

Figure 3. A\_SEL, B\_SEL Input Mode Pins

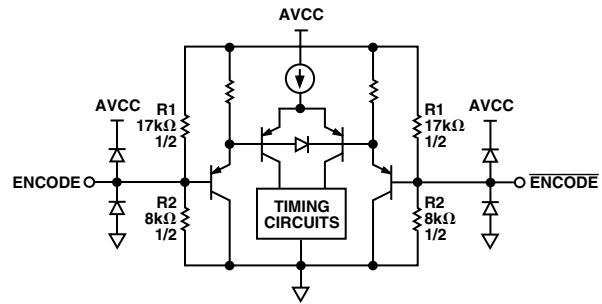

Figure 6. Encode Inputs

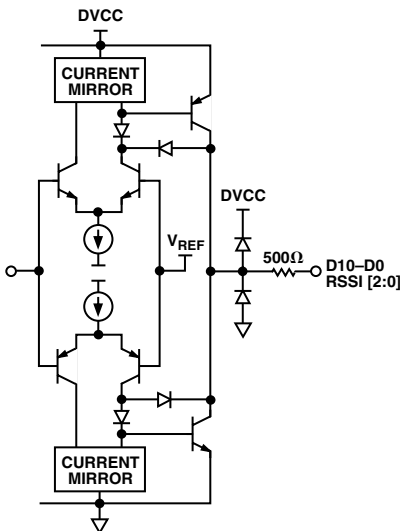

Figure 4. Digital Outputs

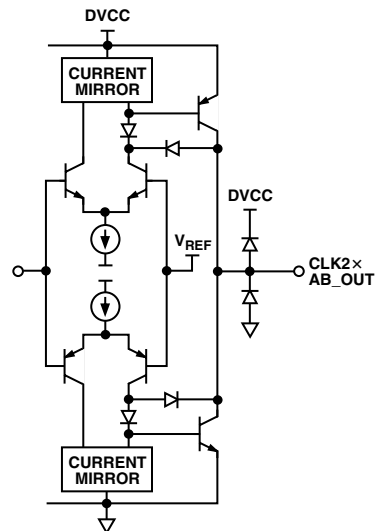

Figure 7. CLK2x, AB\_OUT Outputs

AD6600 TIMING DIAGRAMS

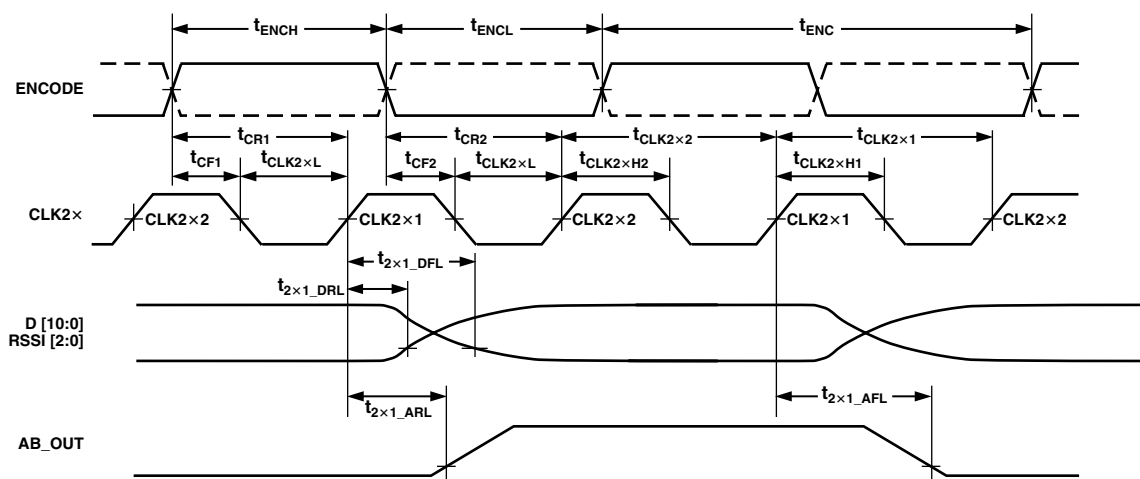

Figure 8. Encode to CLK2x Delays and CLK2x Propagation Delays

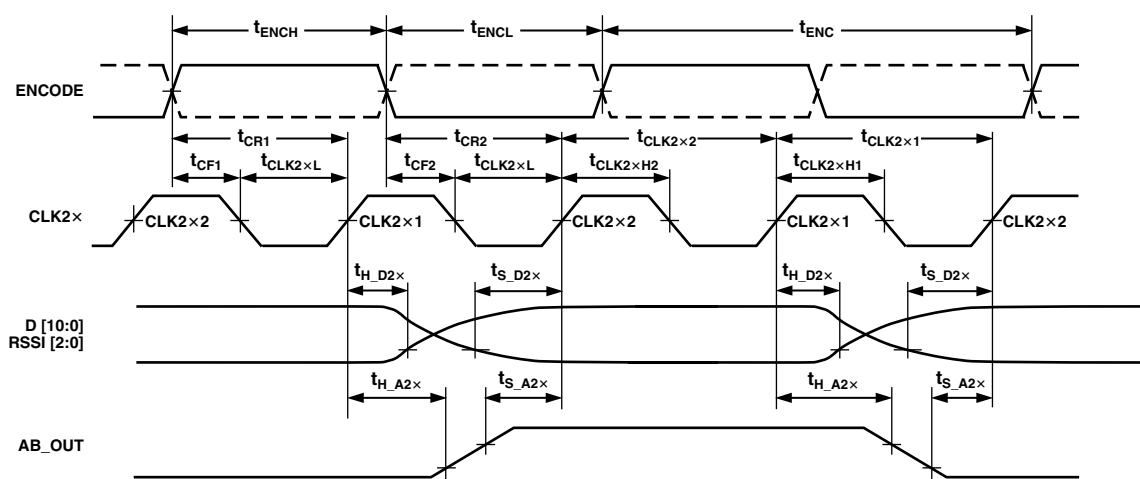

Figure 9. CLK2x Setup-and-Hold Time Characteristics

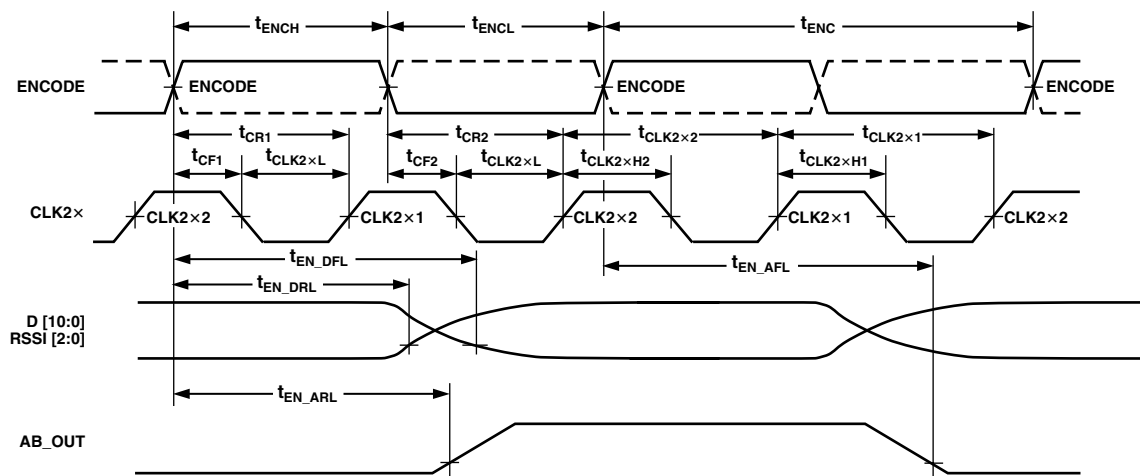

Figure 10. Encode to CLK2x Delays and Encode Propagation Delays

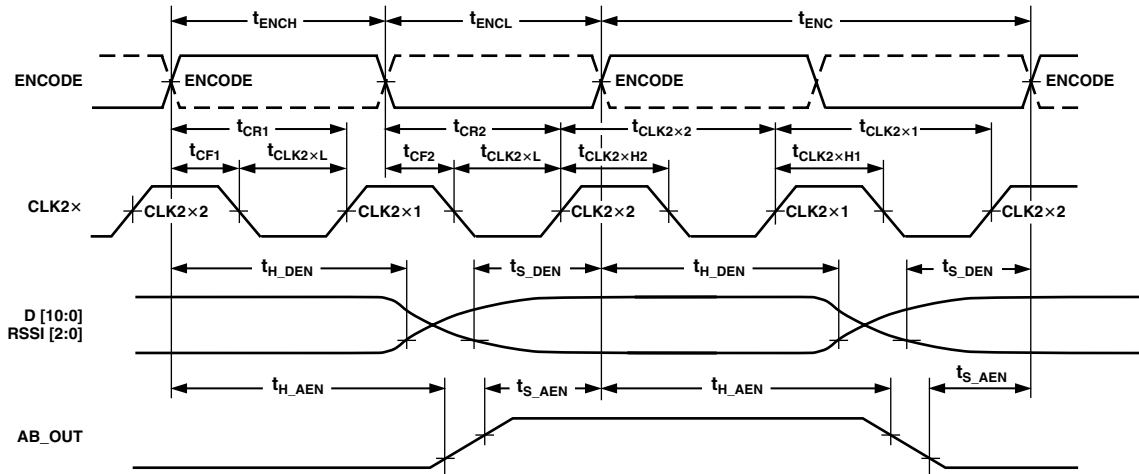

Figure 11. Encode Setup-and-Hold Time Characteristics

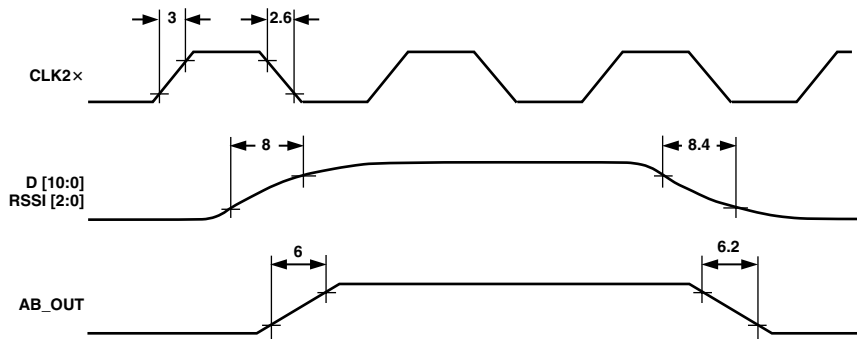

Figure 12. Typical Output Rise and Fall Times

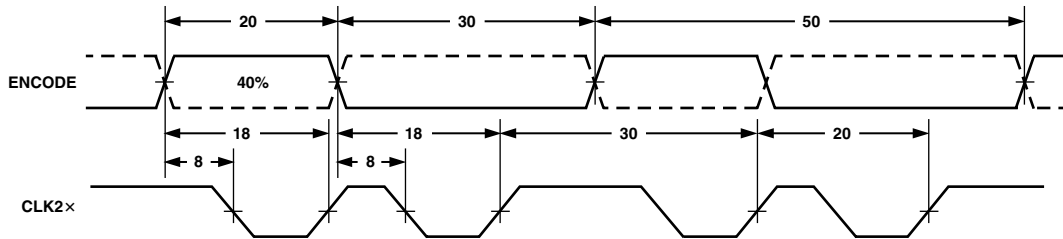

Figure 13. Encode = 20 MSPS, Duty Cycle = 40%

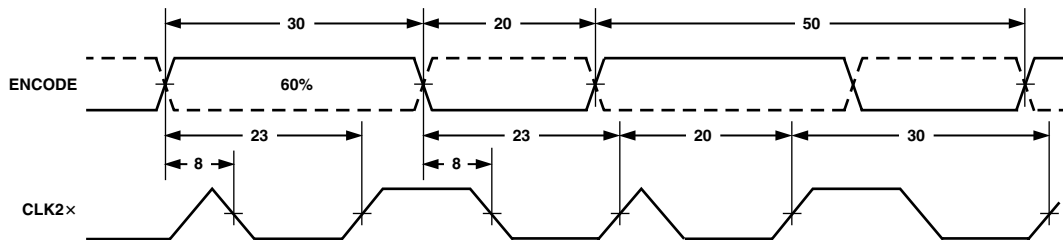

Figure 14. Encode = 20 MSPS, Duty Cycle = 60%

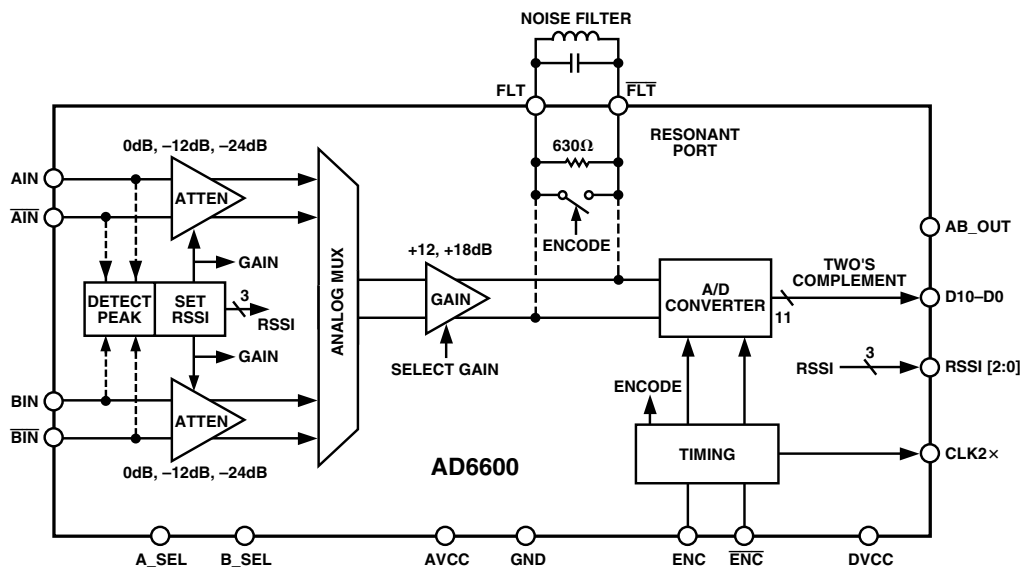

Figure 15. Functional Block Diagram

## THEORY OF OPERATION

The AD6600, dual-channel, gain-ranging ADC integrates analog IF circuitry with high speed data conversion. Each analog input stage is a 1 GHz, 0 dB to  $-24$  dB, phase-compensated step attenuator; the step size in each attenuator is 12 dB. Both input stages drive an analog multiplex function followed by a 12 dB/18 dB gain amplifier. A simple LC noise filter at the output of the gain amplifier is required to resonate at the desired IF. This resonant filter port precedes a wide input bandwidth (450 MHz) track-and-hold followed by an 11-bit analog-to-digital converter (ADC). A high speed synchronous peak detector monitors signal strength at both input channels. The peak detector drives RSSI circuitry that automatically adjusts attenuation and gain on a clock-by-clock basis. The three RSSI indicator bits and the eleven ADC bits are available at the output providing an exponent and mantissa data format. Together these integrated components form an IF sampling, high dynamic range ADC system.

It is helpful to view this device as a stand-alone ADC using automatic gain control. The gain control referred to in this data sheet as “gain-ranging” works to maintain a constant SNR over as wide a range as possible.

As stated previously, the AD6600 has a floating-point output: eleven mantissa bits and three exponent bits. As shown in Figure 16, at the lowest input levels SNR increases 1 dB for a 1 dB increase in input power. In this range, the AD6600 is set for maximum gain. However, when the input signal level reaches the gain-ranging section (approximately  $-42$  dBFS), the SNR is contained between about 50 dB and 56 dB or between 44 dB and 56 dB including the effects of hysteresis. Although Figure 16 does not indicate so, there are slight differences between the SNR from one gain range to the next as the gain amp switches between 12 dB and 18 dB. Once the final RSSI range has been exceeded (approximately  $-12$  dBFS), SNR again increases 1 dB per 1 dB input power increase until converter full scale is reached. Again, this performance is very much like the effects of a typical analog AGC loop.

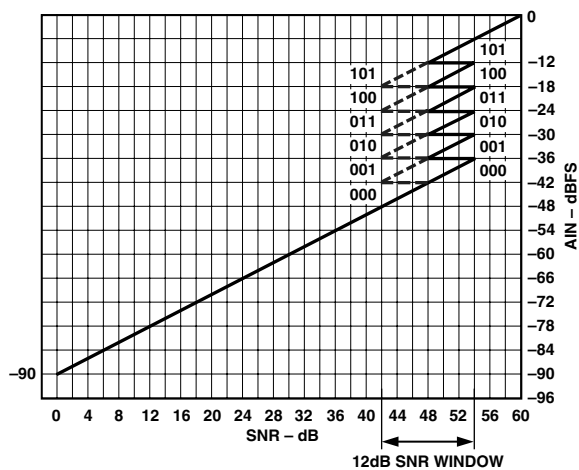

Figure 16. SNR for Gain-Ranging ADC

## AD6600 SUBCIRCUITS

### Input Step Attenuator and Gain Stage

The AD6600 has two identical input attenuators, Channel A and Channel B. These dual inputs are typically used as diversity channels but may also process two independent IF signals. For maximum oversampling the device is used in single channel mode; in this case only one input channel is required. The attenuator steps are 0 dB,  $-12$  dB and  $-24$  dB. The attenuator settings are based on the decisions of the RSSI stage (see Peak Detector/RSSI section). The outputs of the attenuators connect to an analog multiplexer that selects either Channel A or B for subsequent processing (see Input Mode). The selected signal drives a dual-gain amplifier set to either 12 dB or 18 dB; the selected gain is also determined by the RSSI stage. Therefore, based on all possible combinations of attenuation and gain, the input signal receives  $-12$  dB to  $+18$  dB of voltage gain in 6 dB steps (Table I). Overall gain-matching is typically within 0.1 dB. With a bandwidth of 1 GHz, the phase delay through the front-end ranges from 0.2 degrees to 0.5 degrees, depending on input frequency. Additionally, the input impedance does not change with attenuator settings so there is no AM-to-PM distortion.

# AD6600

**Table I. Attenuator and Gain Settings**

Attenuator	Gain Amp	Total	RSSI Word
0 dB	+18 dB	+18 dB	000
0 dB	+12 dB	+12 dB	001
-12 dB	+18 dB	+6 dB	010
-12 dB	+12 dB	0 dB	011
-24 dB	+18 dB	-6 dB	100
-24 dB	+12 dB	-12 dB	101

## High-Speed Peak Detector and RSSI Circuitry

The peak detector along with the attenuator and dual gain amplifier form the control loop within the AD6600.

The peak detector is designed to follow the analog input one clock cycle before the conversion is actually made. Therefore, while the converter section of the AD6600 is converting sample “n,” the peak detector is already looking at sample “n+1.” While looking at the “n+1” sample (the calibration period), the peak detector examines the envelope of the input signal. The more of an envelope that is tracked, the more accurate the gain setting. At the very least, the peak detector must be presented either a positive or negative sinusoidal peak, which represents about one-half of a sine wave cycle. Since the peak detector works for a complete cycle prior to conversion, the absolute minimum IF frequency that can be determined is twice the sample rate per channel. Therefore, at 15 MSPS, the minimum IF frequency that can be sampled would be 30 MHz.

Note that the more cycles of the input that are monitored by the peak detector, the more accurate the gain setting will be. Therefore, the actual minimum IF frequency recommended is higher than this. The minimum specified frequency is 70 MHz. Since the RSSI control loop is performed on a sample-by-sample basis, the AD6600 very accurately follows the signals into and out of a deep fade.

## Hysteresis

The AD6600 employs hysteresis to prevent the gain-ranging from unnecessarily changing when the signal envelope is near an RSSI threshold. The hysteresis is digital and will account for exactly 6 dB of shift, depending on whether the signal is increasing or decreasing. This effect is shown in the dashed lines of the overall transfer function, Figure 16.

## External LC Noise Filter, Resonant Port

The output of the attenuator/gain stage drives the wide bandwidth track-and-hold (T/H), followed by the ADC encoder. Because the attenuator/gain stage has a very wide bandwidth (~1 GHz), an LC filter or “resonant port” is provided to limit the amount of wideband noise delivered to the ADC. The simple LC filter does not provide signal selectivity and should typically be 35 MHz to 50 MHz wide. However, because the ADC’s track-and-hold itself has a wide bandwidth (~450 MHz), this noise-limiting filter is critical to meeting overall sensitivity. Specific details on selecting components for the resonant port are provided later in the text (Understanding the External Analog Filter).

## ADC Encoder

After the calibration period is complete (one clock cycle), the appropriate gain and attenuator settings are determined and set. Once settled, the internal track-and-hold freezes the input signal so that the ADC encoder may digitize the signal. During digitization, the peak detector/RSSI circuitry is already looking at the next sample. When the AD6600 is in dual channel mode, the process is interleaved: while Channel B is monitored for signal strength, Channel A is digitized. This allows the RSSI to update on a clock-by-clock basis.

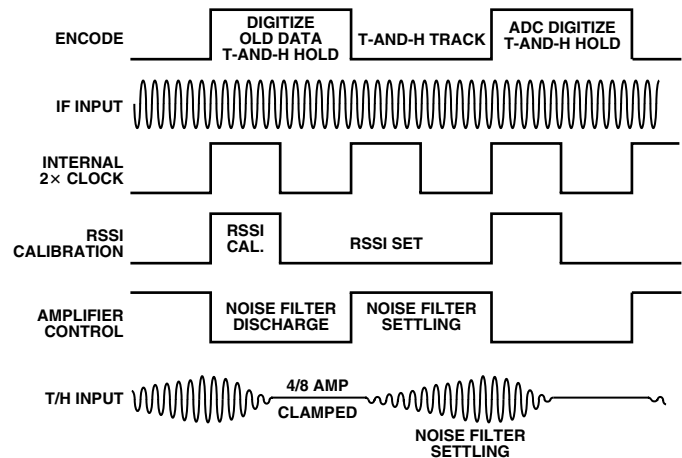

*Figure 17. Internal Timing*

Figure 17 shows the internal timing of the chip. The encode applied to the device initiates several actions. The first and most important is that the track-and-hold is placed in hold, thus sampling the analog input at that instant. The second action is that the peak detector of the RSSI circuitry is initialized. During this period, the analog input envelope is monitored to determine signal power. The AD6600 is in calibration mode for about one-quarter of the encode period.

While the AD6600 is in calibration, the external noise filter is discharged and the amplifier driving the filter disabled. Since this filter is shared between the two input channels in dual channel mode, this greatly reduces the feedthrough between the channels that would otherwise exist. One-quarter of an encode period after the calibration is complete, the amplifier is re-enabled and allowed to settle to its new signal conditions for sampling by the wideband T/H on the next encode signal. The final action is that the signal on the resonant port is sampled by the track-and-hold. This happens on the next rising edge of the encode.

## Input Mode Select

The AD6600 has two operating modes: single channel and dual channel. In single channel mode, the ADC always samples Channel A or always samples Channel B. In dual channel mode, the ADC converter is sampling Channel A and Channel B on alternating Encode cycles. Two control pins are provided to select the desired mode of operation. A\_SEL and B\_SEL arbitrate the selection of how these input channels are connected to the output. Table II shows the truth table for selection of the input.

**Table II. Selecting AD6600 Operating Mode**

Mode	A_SEL	B_SEL	Output vs. Encode Clock			
			n	n+1	n+2	n+3
Dual: A/B	1	1	A	B	A	B
Single: A	1	0	A	A	A	A
Single: B	0	1	B	B	B	B
Not Valid	0	0	–	–	–	–

A\_SEL and B\_SEL are not logic inputs and should be tied directly to ground or analog VCC (5 V analog).

In dual channel mode, the AB\_OUT signal indicates which input is currently available on the digital output. When the AB\_OUT is 1, the digital output is the digitized version of Channel A. Likewise, when AB\_OUT is 0, the Channel B is available on the digital output (Table III).

**Table III. AB\_OUT for Dual Channel Operation**

A_SEL and B_SEL = 1	Output Data vs. Encode Clock			
	n	n+1	n+2	n+3
D[10:0], RSSI[2:0]	A	B	A	B
AB_OUT	1	0	1	0

**Data Output Stage**

The output stage provides data in the form of mantissa, D[10:0], and exponent, RSSI[2:0], where D[10:0] represents the output of the 11-bit ADC coded as two's complement, and RSSI[2:0] represents the gain-range setting coded in offset binary. Table IV shows the nominal gain-ranges for a nominal 2 V p-p differential full-scale input. Keep in mind that the actual full-scale input voltage and power will vary with input frequency.

**Table IV. Interpreting the RSSI Bits**

Differential Analog Input Voltage (V p-p)	RSSI [2:0]		Attenuation or Gain (dB)
	Binary	Decimal Equiv.	
$0.5 < V_{IN}$	101	5	-12
$0.25 < V_{IN} < 0.5$	100	4	-6
$0.125 < V_{IN} < 0.25$	011	3	0
$0.0625 < V_{IN} < 0.125$	010	2	+6
$0.03125 < V_{IN} < 0.0625$	001	1	+12
$V_{IN} < 0.03125$	000	0	+18

The digital processing chip which follows the AD6600 can combine the 11 bits of two's complement data with the 3 RSSI bits to form a 16-bit equivalent output word. Table V explains how the RSSI data can be interpreted when using a PLD or ASIC. Basically, the circuit performs right shifts of the data depending on the RSSI word. This can also be performed in software using the following pseudo code fragment:

```

r0 = dm (rssi);
r2 = 5;
r0 = r2-r0;
r1 = dm (adc); (11 bits, MSB justified into DSP word)
rshift r1, r0; (arithmetic shift to extend the sign bit)

```

The result of the shifted data is a 16-bit fixed-point word that can be used as any normal 16-bit word.

**Table V. 16-Bit, Fixed-Point Data Format**

RSSI	11-Bit Word	16-Bit Data Format	Corresponds to a Shift Right of
101	DATA	DATA× 32	5
100	DATA	DATA× 16	4
011	DATA	DATA× 8	3
010	DATA	DATA× 4	2
001	DATA	DATA× 2	1
000	DATA	DATA× 1	0

When mated with the AD6620, Digital Receive Processor Chip, the AD6600 floating point data (mantissa + exponent) is automatically converted to 16-bit two's complement format by the AD6620.

**APPLYING THE AD6600**

**Encoding the AD6600**

The AD6600 encode signal must be a high quality, extremely low phase noise source to prevent degradation of performance. Digitizing high frequency signals (IF range 70 MHz–250 MHz) places a premium on encode clock phase noise. SNR performance can easily degrade by 3 dB–4 dB with 70 MHz input signals when using a high-jitter clock source. At higher IFs (up to 250 MHz), and with high-jitter clock sources, the higher slew rates of the input signals reduce performance even further. See AN-501, *Aperture Uncertainty and ADC System Performance* for complete details.

For optimum performance, the AD6600 must be clocked differentially. The encode signal is usually ac-coupled into the ENC and ENC pins via a transformer or capacitors. These pins are biased internally and require no additional bias.

Figure 18 shows one preferred method for clocking the AD6600. The sine source (low jitter) is converted from single-ended to differential using an RF transformer. The back-to-back Schottky diodes across the transformer secondary limit clock excursions into the AD6600 to approximately 0.8 V p-p differential. This helps prevent the larger voltage swings of the clock from feeding through to other portions of the AD6600, and limits the noise presented to the encode inputs. A crystal clock oscillator can also be used to drive the RF transformer if an appropriate limiting resistor (typically 100 Ω) is placed in the series with the primary.

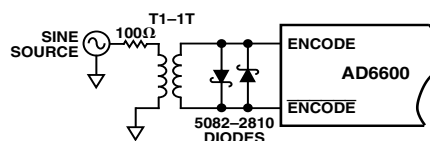

*Figure 18. Transformer-Coupled Sine Source*

# AD6600

If a low jitter ECL/PECL clock is available, another option is to ac-couple a differential ECL/PECL signal to the encode input pins as shown in Figure 19.

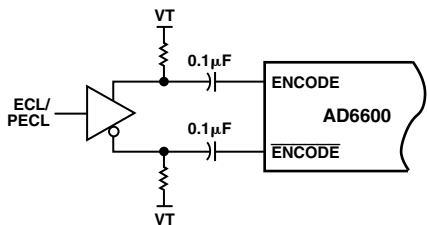

Figure 19. AC-Coupled ECL/PECL Encode

## Driving the Analog Inputs

As with most new high-speed, high dynamic range analog-to-digital converters, the analog input to the AD6600 is differential. Differential inputs allow much improvement in performance on-chip as IF signals are processed through attenuation and gain stages. Most of the improvement is a result of differential analog stages having high rejection of even-order harmonics. There are also benefits at the PCB level. First, differential inputs have high common-mode rejection to stray signals such as ground and power noise. They also provide good rejection to common-mode signals such as local oscillator feedthrough.

Driving a differential analog input introduces some new challenges. Most RF/IF amplifiers are single-ended and may not obviously interface to the AD6600. However, using simple techniques, a clean interface is possible. The recommended method to drive the analog input port is shown in Figure 20. The AD6600 input is actually designed to match easily to a SAW filter such as SAWTEK 855297. This allows the SAW filter to be used in a differential mode, which often improves the operations of a SAW filter. Using network analyzer data for both the SAW filter output and the AD6600 input ports (see data tables for AD6600  $S_{11}$  data), a conjugate match can be used for maximum power transfer. Often an adequate match can be achieved simply by using a shunt inductor to make the port look real (Figure 20). For more details on how to exactly match networks, see *RF Circuit Design* by Chris Bowick, ISBN: 0-672-21868-2.

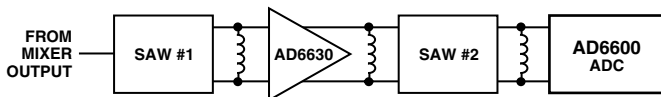

Figure 20. Cascaded SAW Filters with AD6630

Where gain is required, the AD6630 differential, low noise, IF gain block is recommended. This amplifier provides 24 dB of gain and provides limiting to prevent damage to the SAW filter and AD6600. The AD6630 is designed to reside between two SAW filters. This low noise device is ideally suited to many applications of the AD6600. For more information on the AD6630, reference the AD6630 data sheet.

When general purpose gain blocks are used, matching can easily be achieved using a transformer. Most gain blocks are available with 50 Ω input and output ports. Thus matching to the 200 Ω impedance of the AD6600 requires only a 1:4 (impedance ratio) transformer as shown in Figure 21.

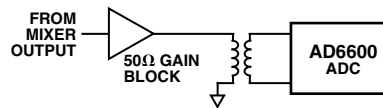

Figure 21. Transformer-Coupled Gain Block

In the rare case that better matching is required, a conjugate match between the amplifier selected and the transformer-coupled analog input can be achieved by placing the matching network between the amplifier and the transformer (Figure 22). For more details on matching, see the reference mentioned previously for more details.

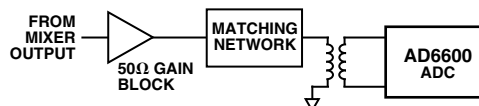

Figure 22. Gain Block and Matching Network

## Understanding the External Analog Filter

Two primary trade-offs must be made when designing the external resonant filter. The obvious one is the bandwidth of the filter. The second, not so obvious, trade-off is settling time of the filter nodes.

Resonant Filter Bandwidth determines the amount of noise that is limited at the center frequency chosen. If the resonant filter is too wide, little noise improvement is seen. If the resonant filter is too narrow, amplitude variation can be seen due to the tolerance of filter components. If the narrow filter is off center due to these tolerances (or drift), the 4×/8× signal will fall on the transition band of the filter. An optimum starting point for this filter is approximately 50 MHz.

Resonant Filter Settling limits the amount of capacitance of this filter. The output of the 4×/8× amplifier is clamped when the ADC is processing its input (encode high time). This prevents the amp output from feeding through to the ADC (T/H) and corrupting the ADC results. But, upon the falling edge of encode, the amp must now come out of clamp and present an accurate signal to the ADC T/H. The RC of the external filter determines the settling of the amp. If the amp output does not settle, the ADC sees an attenuated signal. So obviously, a narrow bandwidth is desired to improve noise performance; but if the filter is too narrow, the amp will not settle and the ADC will see an attenuated signal.

Figure 23 shows a simplified model of the 4×/8× amplifier. A key point to note is that the resistor values in the collector legs are 315 Ω nominal with a tolerance of ±20%. The filter performance is determined by these values in conjunction with the internal parasitic capacitance, board parasitics and the external filter components.

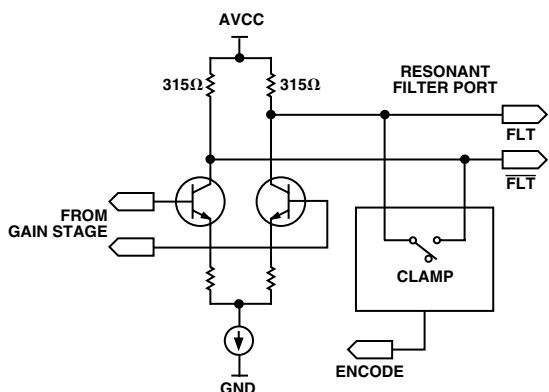

**Figure 23. 4×/8× Amplifier Clamp Circuitry**

Figure 24 shows why settling is important for this circuit. If the 4×/8× amp does not settle (come out of clamp), the amplitude presented to the ADC will be decreased. This results in decreased gain when the filter capacitance is too high.

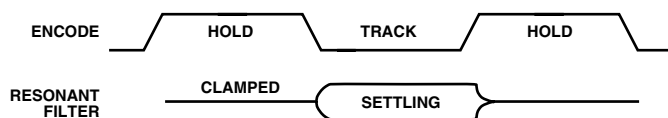

**Figure 24. 4×/8× Amplifier Settling**

This explains why the total capacitance allowed for the external filter varies depending on the clock rate (actually encode clock high time). If the encode is 13 MSPS and the duty cycle is 50%, the allowable settling time is 38.5 ns (1/2 of the encode time). Our assumption is that the amp should be allowed to settle to 1/4 LSB in this time period. This has been proven with both simulation and empirical analysis. If the settling is assumed to be an RC circuit, then:

$$T = RC; t = \text{time}; n = \text{number of bits}$$

$$V_o = A(1 - e^{-t/T})$$

$$A - A/2^n = A(1 - e^{-t/T})$$

$$1 - \frac{1}{2^n} = 1 - e^{-t/T}$$

$$\frac{1}{2^n} = e^{-t/T}$$

$$\frac{t}{T} = \ln\left(\frac{1}{2^n}\right)$$

$$T = \frac{t}{\ln(2^n)}$$

$$C_{TOTAL} = \frac{(T_{ENCODE} \times 0.5)}{R \times \ln(8192)} = \frac{38.5 \text{ ns}}{315 \Omega \times \ln(8192)} = 13.6 \text{ pF}$$

In this case,  $C_{TOTAL}$  includes all parasitics and external capacitance.  $R$  is nominally 315 Ω. The 8192 is  $(4 \times 2048)$ , which is 1/4 LSB of the converter (11 bits, 2048).

So for settling purposes, with 13 MSPS encode and 50% duty cycle, the maximum allowable capacitance for proper settling is  $C_{TOTAL} = 13.6 \text{ pF}$ .

As stated above, this  $C_{TOTAL}$  includes the external capacitors, the board parasitics, and the AD6600 parasitics. The parasitics of the AD6600 (lead, internal bond pad and internal connections) at FLT and  $\overline{\text{FLT}}$  are  $1.75 \text{ pF} \pm 0.35 \text{ pF}$  (differential).

If the resistors are at maximum value  $(315 + 20\%)$ , the maximum allowable capacitance is  $C_{TOTAL} = 11.3 \text{ pF}$ . If the duty cycle is less than 50%, the maximum allowable capacitance is further decreased to allow for settling.

### Power Supplies

Care should be taken when selecting a power source. Linear supplies are strongly recommended. Switching supplies tend to have radiated components that may be “received” by the AD6600. Each of the power supply pins should be decoupled as closely to the package as possible using 0.1 μF chip capacitors.

The AD6600 has separate digital and analog power supply pins. The analog supplies are denoted AVCC and the digital supply pins are denoted DVCC. Although analog and digital supplies may be tied together, best performance is achieved when the supplies are separate. This is because the fast digital output swings can couple switching current back into the analog supplies. Note that AVCC must be held within 5% of 5 Volts; however, the DVCC supply may be varied according to output digital logic family. The AD6600 is specified for DVCC = 3.3 V as this is a common supply for digital ASICs.

### Output Loading

Care must be taken when designing the data receivers for the AD6600. Note from the equivalent circuits shown earlier (see Equivalent Circuits) that D[10:0] and RSSI[2:0] contain a 500 Ω output series resistor. To minimize capacitive loading, there should only be one gate on each output pin. Extra capacitive loading will increase output timing and invalidate timing specifications. CLK2× and AB\_OUT do not contain the output series resistors. Testing for digital output timing is performed with 10 pF loads.

### Layout Information

The schematic of the evaluation board (Figure 25) represents a typical implementation of the AD6600. A multilayer board is recommended to achieve best results. It is highly recommended that high quality, ceramic chip capacitors be used to decouple each supply pin to ground directly at the device. The pinout of the AD6600 facilitates ease of use in the implementation of high frequency, high resolution design practices. All of the digital outputs are segregated to two sides of the chip, with the inputs on the opposite side for isolation purposes.

Care should be taken when routing the digital output traces. To prevent coupling through the digital outputs into the analog portion of the AD6600, minimal capacitive loading should be placed on these outputs. It is recommended that a fanout of only one be used for all AD6600 digital outputs.

The layout of the analog inputs and the external resonant filter are critical. No digital traces must be routed near, under, or above these portions of the circuit. The transformers used for coupling into the analog inputs must be located as close as possible to the analog inputs of the AD6600. The external resonant filter components must be physically close to the filter-input pins, yet separated from the analog inputs.

# AD6600

The layout of the Encode circuit is equally critical. Any noise received on this circuitry will result in corruption in the digitization process and lower overall performance. The Encode clock must be isolated from the digital outputs and the analog inputs.

## Evaluation Board

The evaluation board for the AD6600 is straightforward, containing all required circuitry for evaluating the device. The only external connections required are power supplies, clock and the analog inputs. The evaluation board includes the option for an on-board, clock oscillator for encode.

Power to the analog supply pins of the AD6600 is connected via the power terminal block (TB1). Power for the digital interface is supplied via Pin 1 of J201, or the VDD e-hole located adjacent to J201. The VDD supply can vary between 3.3 V to 5.0 V and sets the level for the output digital data (J201). The J201 connector mates directly with the AD6620 (Receive Signal Processor) evaluation board, Part # AD6620S/PCB, allowing complete evaluation of system performance.

The two analog inputs are connected via SMA connectors AIN and BIN, which are transformer-coupled to the AD6600 inputs. The transformers have a turns-ratio of 1:4 to match the input resistance of the AD6600 (200  $\Omega$ ) to 50  $\Omega$  at the SMA connectors.

The Encode signal may be generated using an on-board crystal oscillator, U100. If an on-board crystal is used, R104 must be removed from the board to prevent loading of the oscillator's output. The on-board oscillator may be replaced by an external encode source via the SMA connector labeled ENCODE. If an external source is used, it must be a high quality and very low phase noise source. The high IF range of the AD6600 (70 MHz –250 MHz) demands that the Encode clock be sufficiently pure to maintain performance.

The AD6600 output data is latched using 74LCX574 (U201, U202) latches. The clock for these latches is determined by jumper selection on header J1. The clock can be a delayed version of the encode clock (CLKA, CLKB), or the CLK2 $\times$  generated by the AD6600. A clock is also distributed with the output data (J201) that is labeled CLKX (Pin 11, J201). The CLK $\times$  is selected with jumpers on header J1 and can be CLKA, CLKB, or CLK2 $\times$ .

The resonant LC filter components (SEL2, C2 and C3) are omitted. The user must install proper values based on the IF chosen. See Understanding the External Analog Filter section of the data sheet for guidelines on selecting these components.

**Table VI. AD6600ST/PCB Bill of Material**

Item	Quantity	Reference	Description
1	3	AIN, BIN, ENCODE	SMA Connector
2	14	C1, C102–108, C114, C117–118, C120–121, C299	Ceramic Chip Capacitor 1206, 0.1 $\mu$ F
3	2	C100–101	Tantalum Chip Capacitor, 10 $\mu$ F
4	1	C111	Ceramic Chip Capacitor 0805, 0.1 $\mu$ F
5	4	C112–C113, C115–116	Ceramic Chip Capacitor 0508, 0.1 $\mu$ F
6	2	CR1–2	1N2810 Schottky Diode
7	1	DUT	AD6600AST
8	1	J1	20-Pin Double Row Male Header
9	1	J201	50-Pin Double Row Male Header, Right Angle
10	2	R1–2	Omitted
11	2	R100–R101	Surface Mount Resistor 1206, 10 k $\Omega$
12	1	R103	Surface Mount Resistor 1206, 100 $\Omega$
13	1	R104	Surface Mount Resistor 1206, 50 $\Omega$
14	2	R298–R299	Surface Mount Resistor 1206, 2 k $\Omega$
15	3	T1–T2, T4	Surface Mount Transformer Mini-Circuits T4–1T
16	1	TB1	PCTB2 Terminal Block
17	2	U201–U202	74LCX574 Octal Latch
18	1	U204	74LVQ00 Two Input NAND Gate

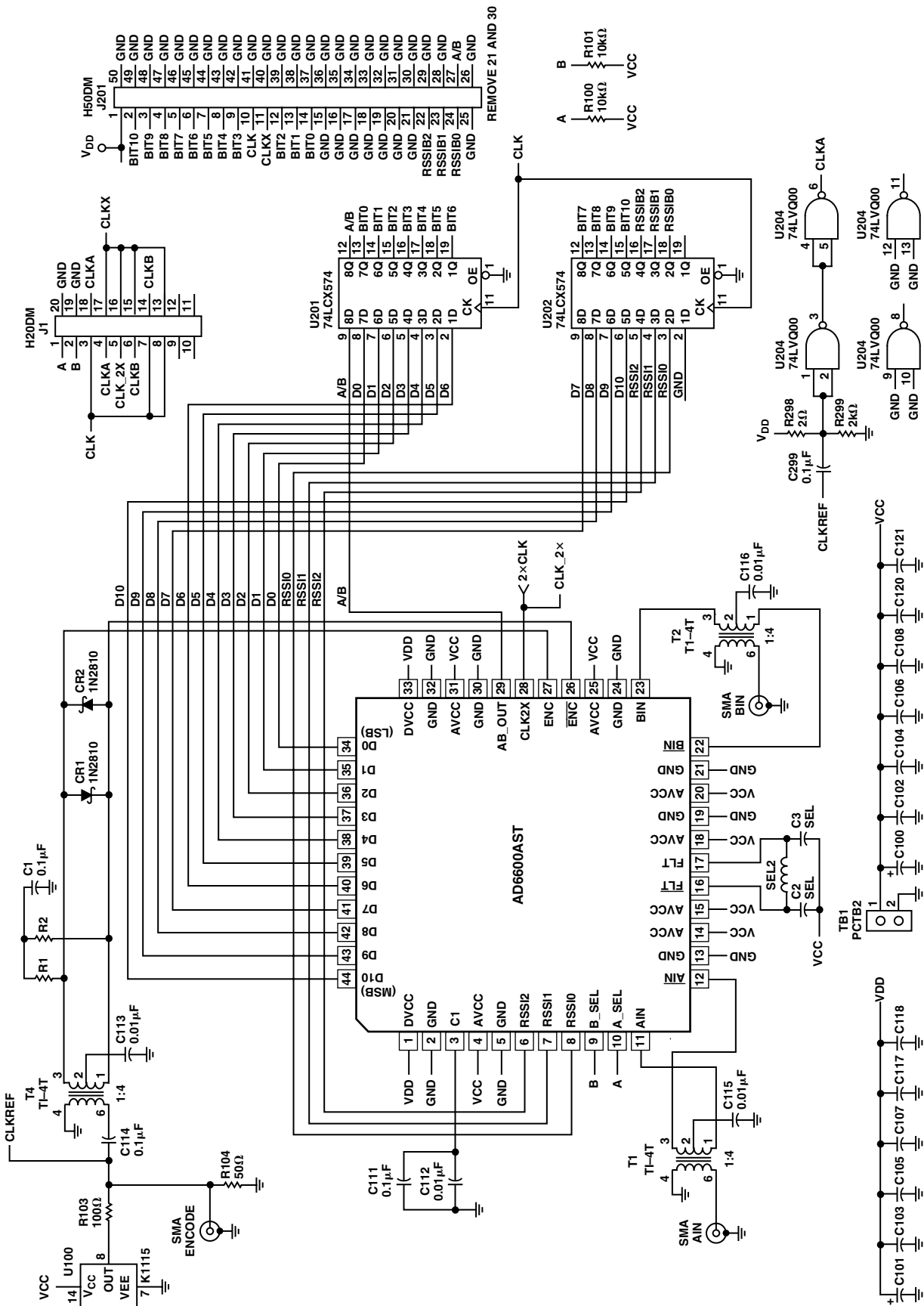

Figure 25. AD6600ST/PCB Schematic Diagram



## Connecting the AD6600 with the AD6620

The AD6600 interfaces directly to the AD6620 Digital Receive Signal Processor as shown in Figure 31. No additional external components are required. Note that the layout requirements discussed previously do apply and deviations can result in degraded performance. The digital outputs of the AD6600 must connect directly to the AD6620 inputs with no additional fanout. Additional loading on the outputs will compromise timing performance.

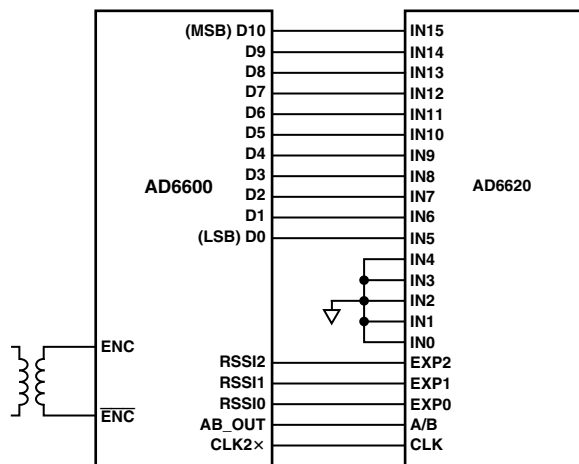

Figure 31. AD6600/AD6620 Connections

Figure 32 shows the timing details between the AD6600 and the AD6620. On Clock 1, D[10:0], RSSI[2:0], and AB\_OUT are captured by the AD6620. Since AB\_OUT has changed state from the previous clock, the D[10:0] and RSSI[2:0] are processed by the AD6620. This clock allows adequate setup and hold time for AB\_OUT, D[10:0], and RSSI[2:0] to be captured by the AD6620.

On Clock2, D[10:0], RSSI[2:0], and AB\_OUT are captured by the AD6620. Since AB\_OUT has not changed from the previous clock, the D[10:0] and RSSI[2:0] are ignored by the AD6620. This clock is concerned only with the AB\_OUT setup-and-hold time.

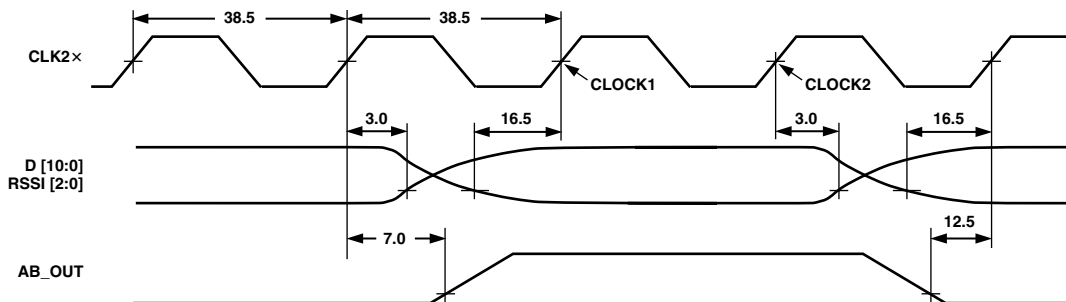
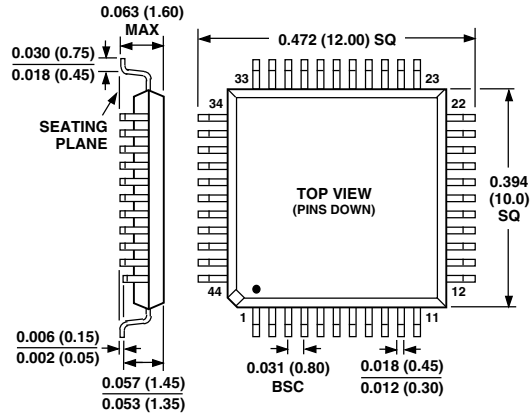

Figure 32. AD6600 to AD6620 Timing at 13 MSPS

## OUTLINE DIMENSIONS

Dimensions shown in inches and (mm).

### 44-Terminal LQFP (Low-Profile Quad Plastic Flatpack) (ST-44)





LittleDiode supplies new, hard to find or obsolete electronic components and semiconductors all over the world.

With over two million different components listed you are sure to find the part you need.

Feel free to visit us today at our online store:

[LittleDiode.com](http://LittleDiode.com)

Looking forward to providing you with the best possible service.