

**RGB VIDEO OUTPUT AMPLIFIER**

- THREE INDEPENDENT VIDEO AMPLIFIERS WITH TYPICAL SR > 1000V/ $\mu$ s
- CRT-CATHODE SENSING OUTPUT FOR SEQUENTIAL SAMPLING
- INTERNAL G1 VOLTAGE GENERATOR
- CATHODE SHORT CIRCUIT PROTECTION
- FLASHOVER PROTECTION OF THE OUTPUT STAGES
- COMPENSATES POSITIVE AND NEGATIVE TUBE LEAKAGES

**DESCRIPTION**

Realized with a high voltage bipolar technology, the TDA8153 is a monolithic RGB video output stage for TV color applications. It drives the CRT cathodes directly and offers a video bandwidth compatible with CCIR standards. In addition to three independent video amplifiers, the device features an internal generator for the first grid voltage, flashover protection, cathode short circuit protection and a common cut-off sensing output for use in sequential sampling applications.

The TDA8153 is supplied in a 15 lead Multiwatt plastic power package.

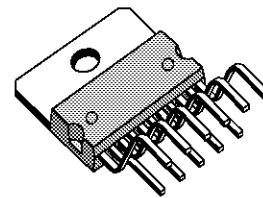

**MULTIWATT15**  
(Plastic Package)

**ORDER CODE : TDA8153**

**PIN CONNECTIONS**

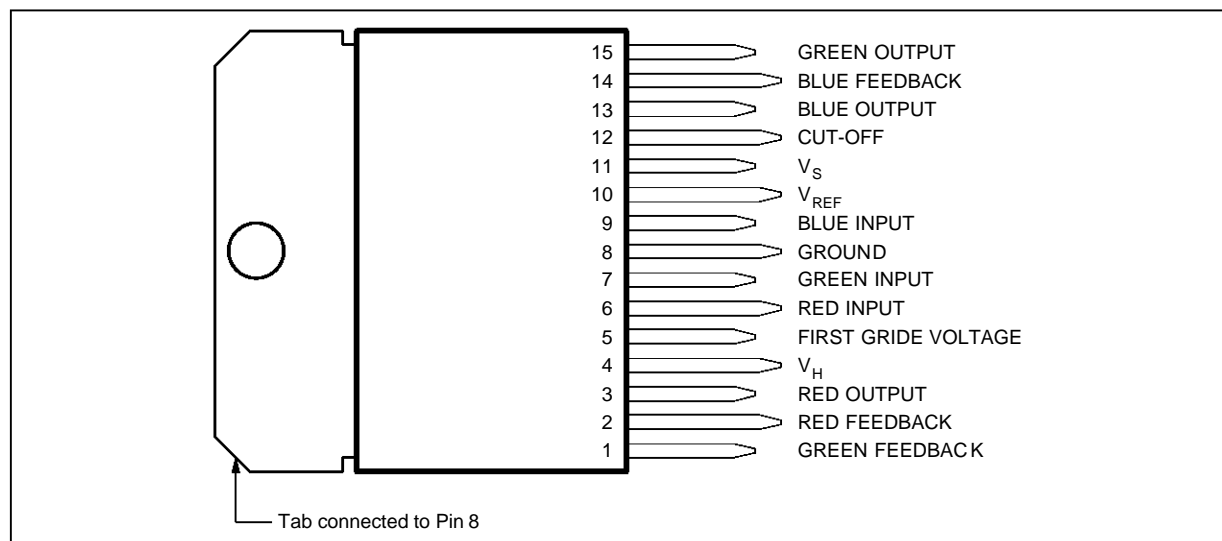

8153-01.EPS

# TDA8153

## PIN FUNCTIONS

N°	Name	Function
1	GREEN FEEDBACK	Feedback Output for 'Green' Amplifier. The optimal value for the resistor connected here to set gain is 68kΩ as shown in fig. 1.2. Other feedback connections are pin 2 (red) and pin 14 (blue).
2	RED FEEDBACK	Feedback Output for 'Red' Amplifier. See pin 1.
3	RED OUTPUT	Output of 'Red' Video Amplifier. See pin 15.
4	V <sub>H</sub>	High Voltage Supply for Amplifier Stages, Typically 200V (see fig. 1.2).
5	FIRST GRID VOLTAGE	Output providing DC voltage for first grid of CRT, typically V <sub>s</sub> + V <sub>BE</sub> .
6	RED INPUT	Input of 'Red' Video Amplifier. See pin 7.
7	GREEN INPUT	Input of 'Green' Video Amplifier. The bias voltage at the inputs is equal to V <sub>ref</sub> + 2V <sub>BE</sub> . Other inputs are pin 6 (red) and pin 9 (blue).
8	GROUND	Ground Connection (pin 8 is also connected to the tab).
9	BLUE INPUT	Input of 'Blue' Video Amplifier. See pin 7.
10	V <sub>ref</sub>	The reference voltage for the three amplifiers is available on this pin. Typical value is 1.6V. The capacitor connected between pin 10 and ground eliminates AC crosstalk between the amplifiers.
11	V <sub>s</sub>	Supply Voltage Input for Low Voltage Circuitry, typically 12V.
12	SAMPLING	Cathode Current Sampling Output. Provides sum of cathode currents for automatic cut-off adjustment with video processors using the sequential system. The three current generators I <sub>1</sub> , I <sub>2</sub> and I <sub>3</sub> bias the inputs of this circuit which performs the cut-off adjustment, allowing also adjustment with in flowing CRT leakages.
13	BLUE OUTPUT	Output of 'Blue' Video Amplifier. See pin 15.
14	BLUE FEEDBACK	Feedback Output for 'Blue' Amplifier. See pin 1.
15	GREEN OUTPUT	Output of the 'Green' Video Amplifier. The output is protected against CRT flashovers. Other outputs are pin 3 (red) and pin 13 (blue).

8153-01.TBL

## SCHEMATIC DIAGRAM

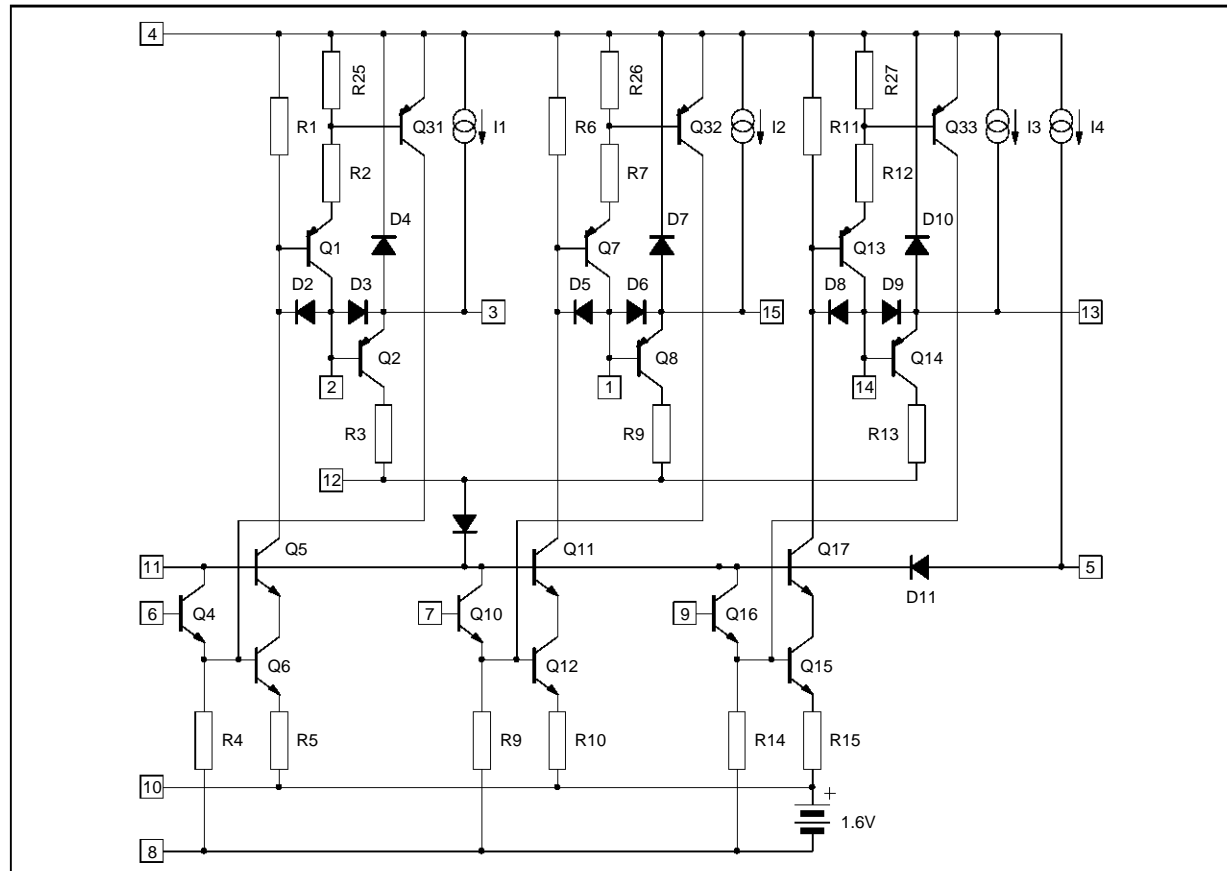

8153-02.EPS

**BLOCK DIAGRAM**

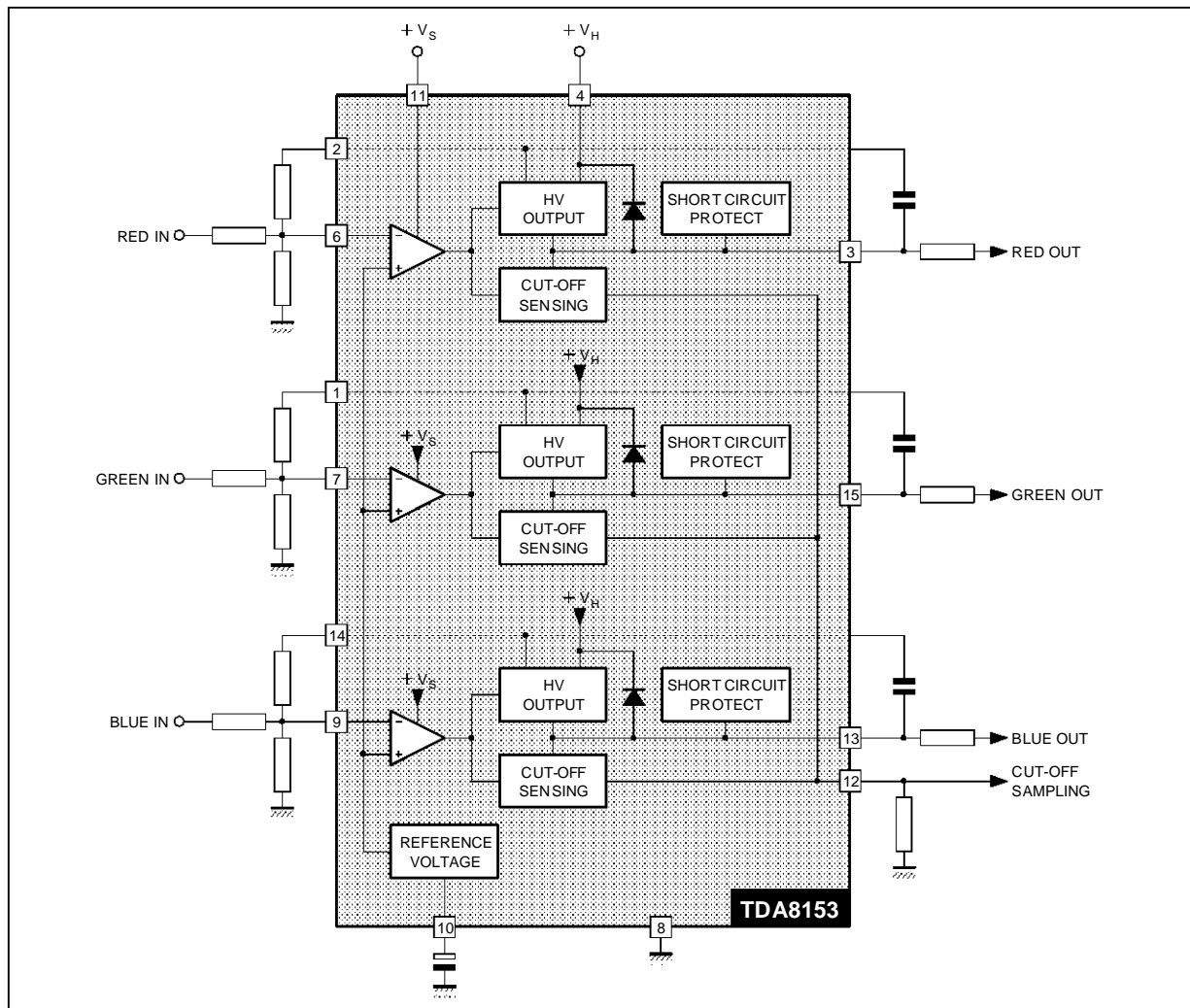

8153-03.EPS

**ABSOLUTE MAXIMUM RATINGS**

Symbol	Parameter	Value	Unit
$V_H$	High Voltage Supply	250	V
$V_S$	Low Voltage Supply	35	V
$P_{tot}$	Power Dissipation at $T_{case} = 90^{\circ}C$	20	W
$V_I$	Input Voltage	$V_S$	
$T_{stg}, T_j$	Storage and Junction Temperature	- 25, + 150	$^{\circ}C$
$T_{oper}$	Operating Ambient Temperature	0, + 70	$^{\circ}C$

8153-02.TBL

**THERMAL DATA**

Symbol	Parameter	Value	Unit
$R_{th(j-c)}$	Thermal Resistance Junction-case	Max 3	$^{\circ}C/W$

8153-03.TBL

## TDA8153

**ELECTRICAL CHARACTERISTICS** (ref. to test and application circuits,  $V_{HT} = 200V$ ,  $V_S = 12V$ ,  $C_L = 10pF$  \*, heatsink  $R_{th} = 9^{\circ}C/W$ ,  $T_{amb} = 25^{\circ}C$  unless otherwise specified)

Symbol	Parameter	Test Conditions	Pin	Min.	Typ.	Max.	Unit	Fig.
$V_{HT}$	High Voltage Supply		4		200	220	V	1-2
$V_S$	Low Voltage Supply		11	10.8	12	13.2	V	1-2
$I_{HT}$	Quiescent Drain Current	$V_{in} = 0$ , $V_{odc} = V_{sat H}$	4		10	15	mA	1
$I_S$	Quiescent Drain Current	$V_{in} = 0$ , $V_{odc} = V_{sat H}$	11		10	17	mA	1
$V_{ref}$	Reference Voltage		10	1.4	1.6	1.9	V	1
$V_{g1}$	CRT G1 Voltage Supply		5		$V_S + V_{be}$		V	1
$V_{sat}$	H Output Saturation	$V_{in} = 0$ , $V_{dc} = -3V$	3 13 15		$V_{HT}$ -3V		V	1
$V_{sat}$	L Output Saturation	$V_{in} = 0$ , $V_{dc} = 9V$	3 13 15		$V_S$		V	1
$I_1, I_2, I_3$		See schematic diag. $V_{in} = 0$ ; $V_{odc} = 150V$	12	7	15	20	$\mu A$	1
$V_{odc}$	Quiescent Output Voltage	Inputs Floating	3 13 15		123		V	1
$V_o$	Peak-to-peak Output Swing	$f = 10kHz$	3 13 15	170			Vpp	1
$\frac{\Delta V_{odc}}{\Delta T}$	DC Output Voltage versus Temperature	$V_{odc} = 150V$ $T_{amb} = 0 \div 70^{\circ}C$	3 13 15		0.03		V/ $^{\circ}C$	1
$\frac{\Delta V_{odc}}{\Delta T}$	DC Differential Voltage versus Temperature	$V_{odc} = 150V$ $T_{amb} = 0 \div 70^{\circ}C$	3 13 15			0.015	V/ $^{\circ}C$	1
$G_{Vo}$	Open-loop Gain	$V_{in} = 50mV_{pp}$ , $f = 10kHz$		50	56		dB	1
$G_{Vc}$	Closed-loop Gain	$V_{in} = 1.5V_{pp}$ , $f = 10kHz$		20	25		dB	1
$B_w$	Video Bandwidth (-3 dB)	$V_{obl} = 125V$ , 0dB at $f = 100kHz$ $V_o =$ 80Vpp 50Vpp 10Vpp		4.5 6.5 12	6.0 8.0 15		MHz	2
$t_r$	Rise Time	$V_o = 100V_{pp}$ ; $V_{obl} = 150V$ $f = 100kHz$ , Duty Cycle = 0.5			80	120	ns	2
$t_f$	Fall Time	$V_o = 100V_{pp}$ ; $V_{obl} = 150V$ $f = 100kHz$ , Duty Cycle = 0.5			80	120	ns	2
$\Delta T$	Differential Rise and Fall Time					20	ns	2
	Overshoot	$V_o = 100V_{pp}$ , $V_{obl} = 150V$ $f = 100kHz$ , Duty Cycle = 0.5				5	%	2
	Undershoot	$V_o = 100V_{pp}$ ; $V_{obl} = 150V$ $f = 100kHz$ , Duty Cycle = 0.5				5	%	2

8153-04.TBL

\*  $C_L = 10pF$  is the sum of the P.C. board capacitance (with socket) and the cathode capacitance of the CRT.

TEST CIRCUIT

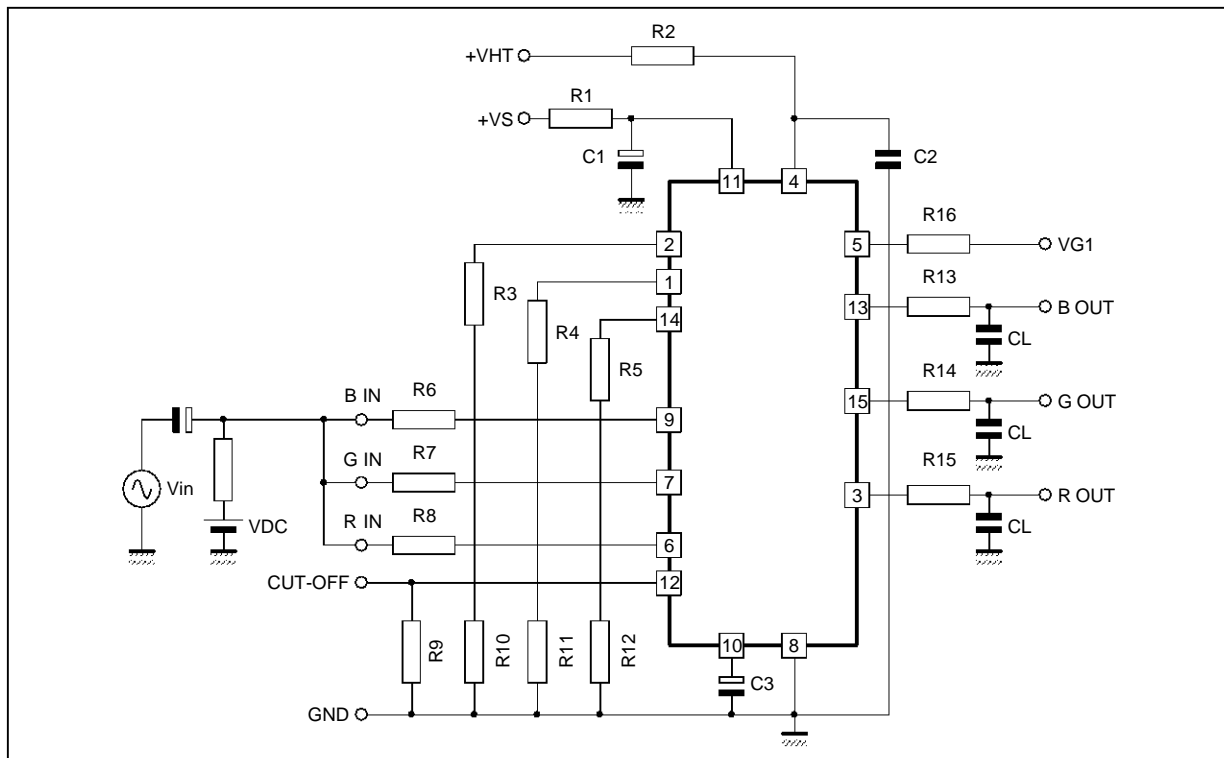

81.53-04.EPS

TEST CIRCUIT

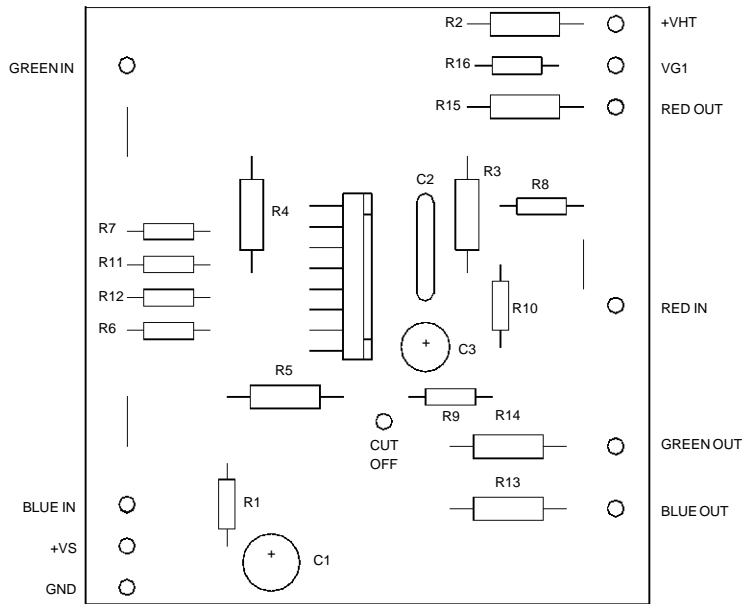
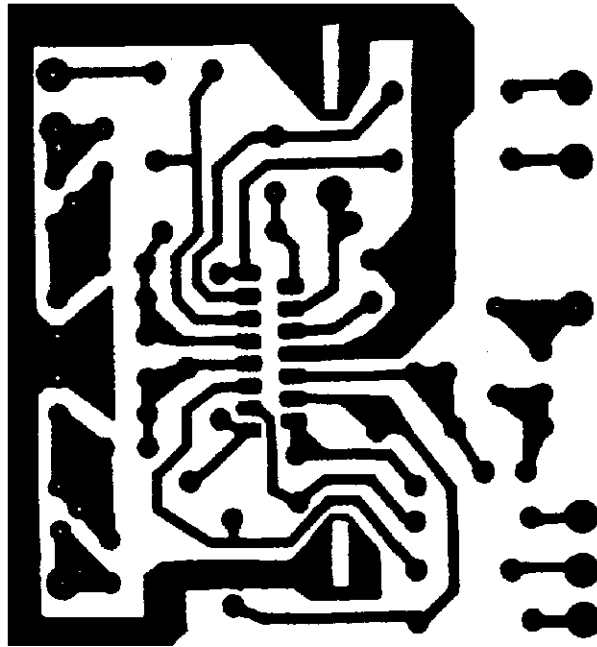

R1 = 10Ω  
 R2 = 220Ω 1/2W  
 R3 = 68kΩ 1/2W  
 R4 = 68kΩ 1/2W  
 R5 = 68kΩ 1/2W  
 R6 = 3kΩ  
 R7 = 3kΩ  
 R8 = 3kΩ

R9 = 47kΩ  
 R10 = 1.8kΩ 1/2W  
 R11 = 1.8kΩ 1/2W  
 R12 = 1.8kΩ 1/2W  
 R13 = 1kΩ 1/2W  
 R14 = 1kΩ 1/2W  
 R15 = 1kΩ 1/2W  
 R16 = 2.2kΩ

C1 = 4μF 16V  
 C2 = 100nF 250V  
 C3 = 10μF 16V

8153-05.TIF / 8153-06.EPS



APPLICATION CIRCUIT

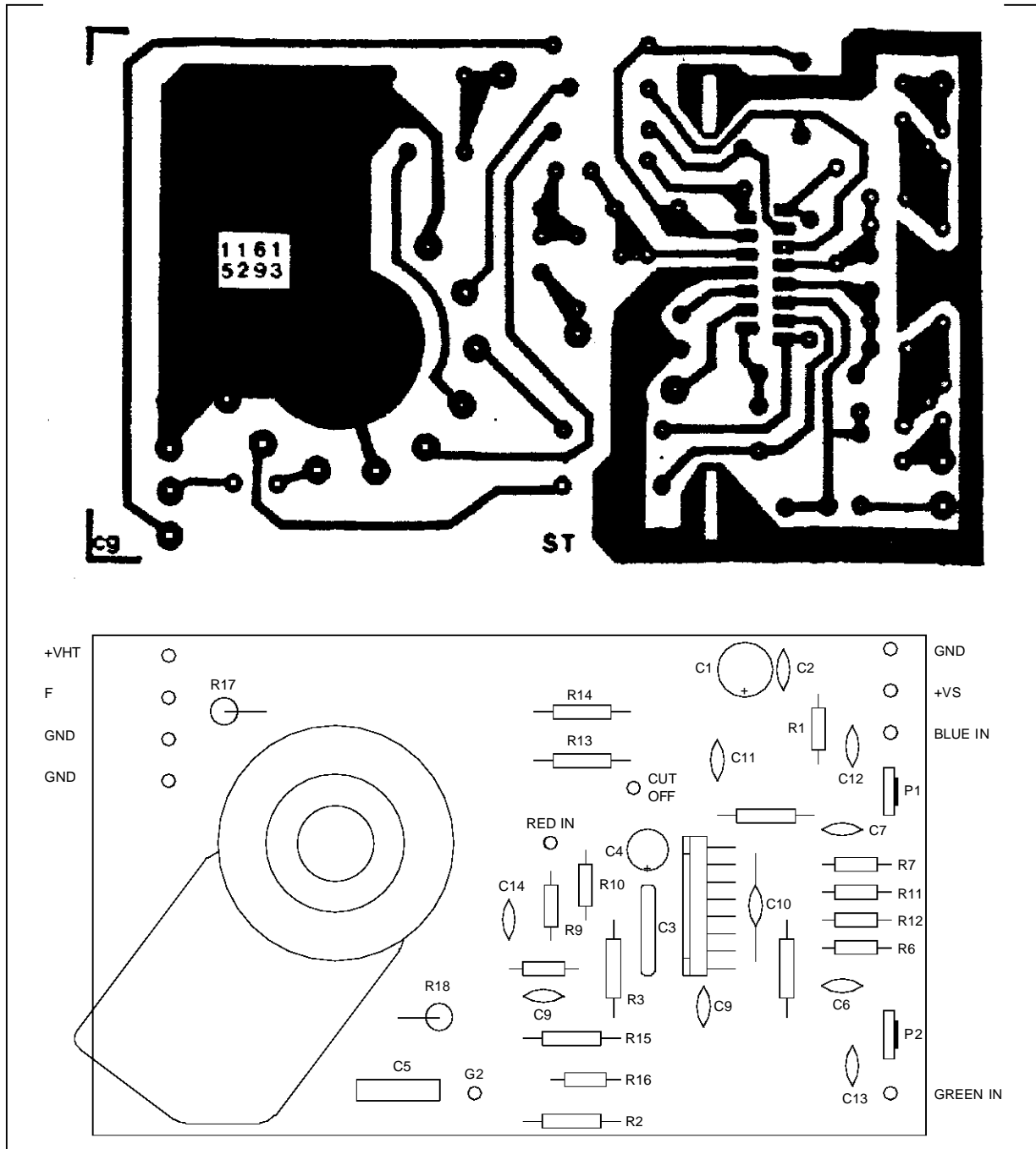

8153-08.TIF / 8153-09.EPS

Figure 1 : Video Bandwith

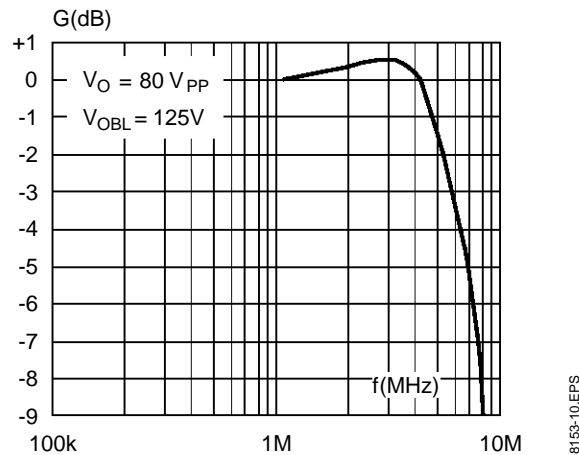

Figure 2 : Fall Time

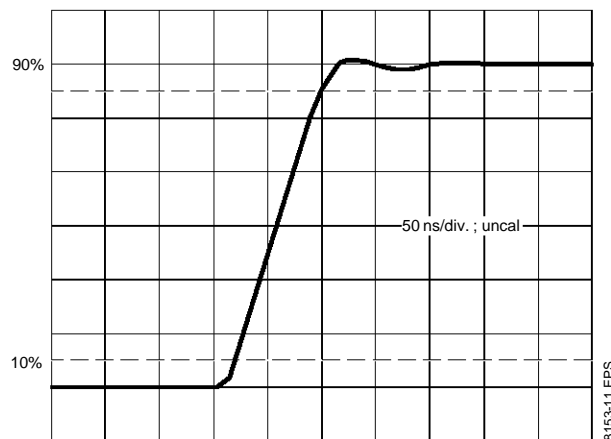
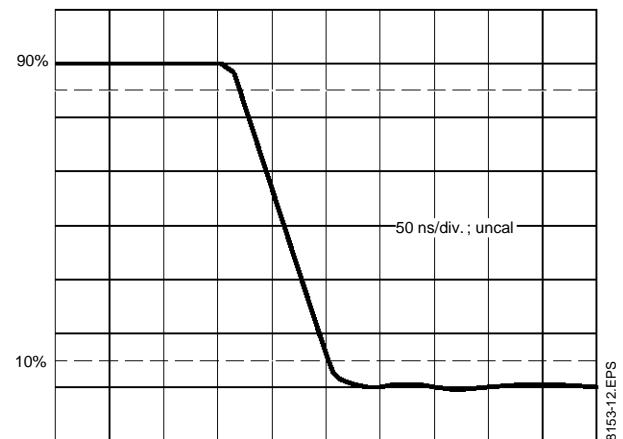

Figure 3 : Rise Time



## APPLICATION NOTES

### P. C. Board

The best performance of the RGB video amplifier can be obtained only with a carefully designed P.C. board. The layout of the printed circuit must be realized to achieve the best possible symmetry of the three channels.

Output to input capacitances are of particular importance. The input-output capacitances, in parallel with the relative high feedback resistances, create poles in the closed loop transfer function.

To optimize the band response and to minimize the channels crosstalk a low parasitic capacitance feedback resistors of not inductive type is necessary.

Capacitive coupling from the output of an amplifier and the input of another one may induce excessive crosstalk. It is advisable to keep the amplifier outputs away from amplifier inputs.

The small size of the P.C. board allows you to

mount the TDA8153 directly beside the picture tube socket, to minimize the capacitances of the connections between the video amplifiers and the picture tube cathodes.

The capacitors connected in parallel with the input resistors compensate the effects of the distributed constants of the printed circuit on the step response times. Their values must be selected on the basis of the layout and can be considered as function of the printed circuit.

The three capacitors (C9, C10, C11) between the amplifier outputs and the feedback resistors reduce the noise effect on the cut-off control, their value, of course, depends on the noise amplitude and spectrum coming from the I.F. video stage.

To prevent possible oscillation problems, it is necessary to place the high voltage filter capacitor (C3) as near as possible to the IC ground and the latter must be of a substantial width.

**Power Dissipation**

Taking as reference the IC internal schematic diagram we can calculate the power dissipated by the video amplifiers.

The power dissipation of the IC is defined by a static and a dynamic part.

The statically dissipated power is given by :

$$P_S = 3 V_{ht} \left( \frac{V_{ht} - V_{obl}}{R_1} + \frac{V_{obl}}{R_f} \right) - 3 \frac{V_{obl}^2}{R_f} - 3 \frac{(V_{ref} + 2V_{be})^2}{R_b}$$

Where  $R_f$  is the feedback resistance and  $R_b$  the input to ground resistance with a black level  $V_{obl} = 150V$ ,  $V_{ht} = 200V$ ,  $R_f = 68k\Omega$  and  $R_b = 1.8k\Omega$  we have :  $P_S = 1.75W$

The dynamic power dissipation has been calculated with a 5MHz, 80Vpp sinusoidal output signal and a load capacitor  $C_L = 10pF$  with the following expression :

$$P_d = \left[ 0.8 V_{ht} (2f C_L V_{op}) - 0.8 \frac{V_{op}^2}{2R_f} \right] = 1.90W$$

The value is reduced by 20% (0.8 factor) because during the flyback time there is not signal.

The total power dissipated by the IC is therefore :  $P_T = P_S + P_d = 1.75 + 1.90 = 3.65W$

One of the worst working condition of the TV set as regards the power dissipation, is when you get white noise on the screen, for example, when you disconnect the TV aerial or the channels are not properly tuned.

In these cases if we set the TV receiver for 80Vpp

white noise output signal with a black level  $V_{obl} = 125V$ , the total power dissipated by the IC can be measured.

It results about  $P_T = 4.8W$ .

With a maximum ambient temperature of 70°C and a junction temperature of 150°C a 15°C/W heatsink is required.

**Figure 4 :** Maximum Allowable Power Dissipation versus Ambient Temperature

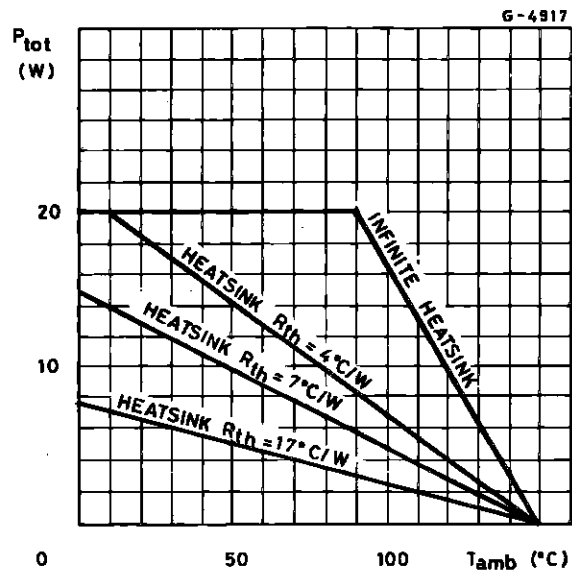

**Figure 5 :** Mounting Examples

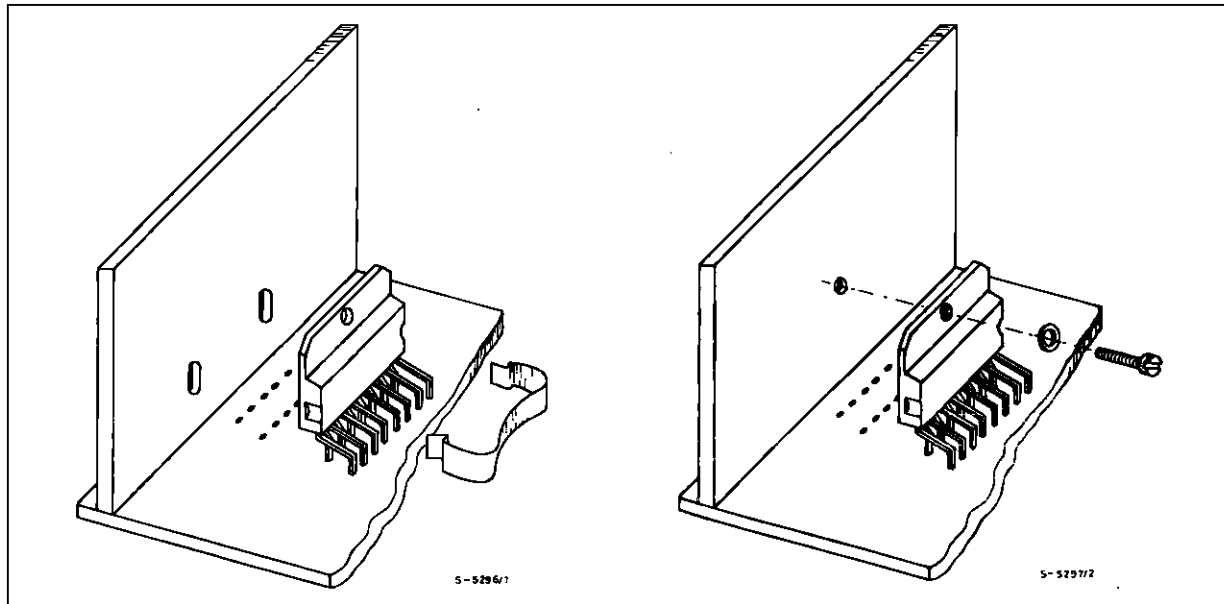

PACKAGE MECHANICAL DATA: 15 PINS - PLASTIC MULTIWATT

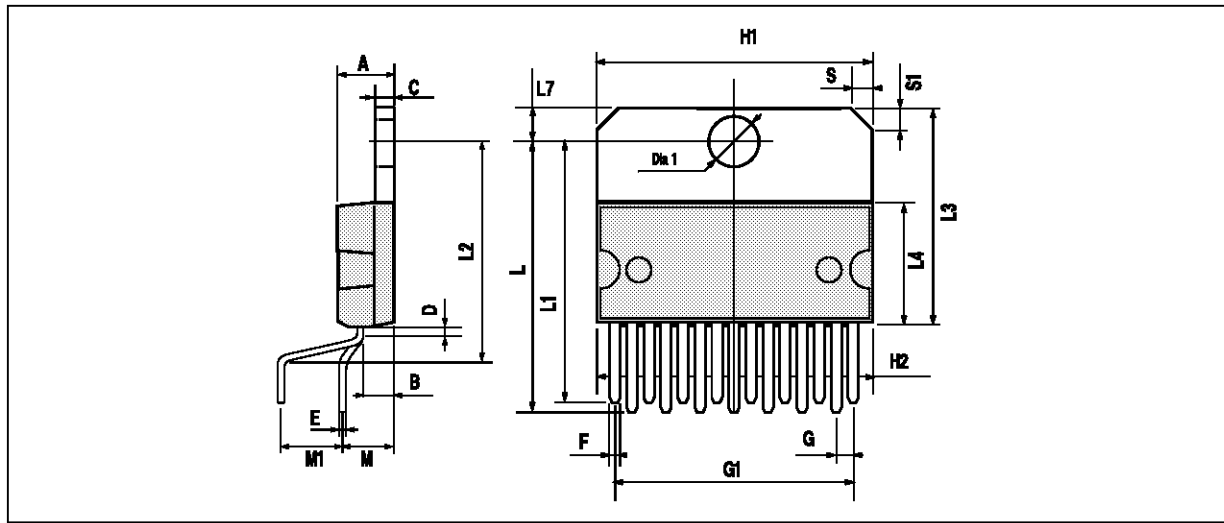

PMUL15V/EP5

Dimensions	Millimeters			Inches		
	Min.	Typ.	Max.	Min.	Typ.	Max.
A			5			0.197
B			2.65			0.104
C			1.6			0.063
D		1			0.039	
E	0.49		0.55	0.019		0.022
F	0.66		0.75	0.026		0.030
G	1.14	1.27	1.4	0.045	0.050	0.055
G1	17.57	17.78	17.91	0.692	0.700	0.705
H1	19.6			0.772		
H2			20.2			0.795
L	22.1		22.6	0.870		0.890
L1	22		22.5	0.866		0.886
L2	17.65		18.1	0.695		0.713
L3	17.25	17.5	17.75	0.679	0.689	0.699
L4	10.3	10.7	10.9	0.406	0.421	0.429
L7	2.65		2.9	0.104		0.114
M	4.2	4.3	4.6	0.165	0.169	0.181
M1	4.5	5.08	5.3	0.177	0.200	0.209
S	1.9		2.6	0.075		0.102
S1	1.9		2.6	0.075		0.102
Dia. 1	3.65		3.85	0.144		0.152

MUL15V.TBL

Information furnished is believed to be accurate and reliable. However, SGS-THOMSON Microelectronics assumes no responsibility for the consequences of use of such information nor for any infringement of patents or other rights of third parties which may result from its use. No licence is granted by implication or otherwise under any patent or patent rights of SGS-THOMSON Microelectronics. Specifications mentioned in this publication are subject to change without notice. This publication supersedes and replaces all information previously supplied. SGS-THOMSON Microelectronics products are not authorized for use as critical components in life support devices or systems without express written approval of SGS-THOMSON Microelectronics.

© 1994 SGS-THOMSON Microelectronics - All Rights Reserved

Purchase of I<sup>2</sup>C Components of SGS-THOMSON Microelectronics, conveys a license under the Philips I<sup>2</sup>C Patent. Rights to use these components in a I<sup>2</sup>C system, is granted provided that the system conforms to the I<sup>2</sup>C Standard Specifications as defined by Philips.

SGS-THOMSON Microelectronics GROUP OF COMPANIES

Australia - Brazil - China - France - Germany - Hong Kong - Italy - Japan - Korea - Malaysia - Malta - Morocco  
The Netherlands - Singapore - Spain - Sweden - Switzerland - Taiwan - Thailand - United Kingdom - U.S.A.