



# SPECIFICATIONS

## ELECTRICAL

At  $T_A = +25^\circ\text{C}$  with  $\pm 15\text{VDC}$  power supply and in circuit of Figure 2, unless otherwise noted.

PARAMETER	CONDITIONS	INA102AG			INA102CG			INA102KP/INA102AU			UNITS
		MIN	TYP	MAX	MIN	TYP	MAX	MIN	TYP	MAX	
<b>GAIN</b>											
Range of Gain		1		1000	*		*	*		*	V/V
Gain Equation, External, $\pm 20\%$		$G = 1 + (40k/R_G)^{(1)}$					*		*		V/V
Error, DC: $G = 1$	$T_A = +25^\circ\text{C}$			0.1			0.05			0.15	%
$G = 10$	$T_A = +25^\circ\text{C}$			0.1			0.05			0.35	%
$G = 100$	$T_A = +25^\circ\text{C}$			0.25			0.15			0.4	%
$G = 1000$	$T_A = +25^\circ\text{C}$			0.75			0.5			0.9	%
$G = 1$	$T_A = T_{\text{MIN}}$ to $T_{\text{MAX}}$			0.16			0.08			0.21	%
$G = 10$	$T_A = T_{\text{MIN}}$ to $T_{\text{MAX}}$			0.19			0.11			0.44	%
$G = 100$	$T_A = T_{\text{MIN}}$ to $T_{\text{MAX}}$			0.37			0.21			0.52	%
$G = 1000$	$T_A = T_{\text{MIN}}$ to $T_{\text{MAX}}$			0.93			0.62			1.08	%
Gain Temp. Coefficient										*	ppm/ $^\circ\text{C}$
$G = 1$				10			5			*	ppm/ $^\circ\text{C}$
$G = 10$				15			10			*	ppm/ $^\circ\text{C}$
$G = 100$				20			15			*	ppm/ $^\circ\text{C}$
$G = 1000$				30			20			*	ppm/ $^\circ\text{C}$
Nonlinearity, DC										*	% of FS
$G = 1$	$T_A = +25^\circ\text{C}$			0.03			0.01			*	% of FS
$G = 10$	$T_A = +25^\circ\text{C}$			0.03			0.01			*	% of FS
$G = 100$	$T_A = +25^\circ\text{C}$			0.05			0.02			*	% of FS
$G = 1000$	$T_A = +25^\circ\text{C}$			0.1			0.05			*	% of FS
$G = 1$	$T_A = T_{\text{MIN}}$ to $T_{\text{MAX}}$			0.045			0.015			*	% of FS
$G = 10$	$T_A = T_{\text{MIN}}$ to $T_{\text{MAX}}$			0.045			0.015			*	% of FS
$G = 100$	$T_A = T_{\text{MIN}}$ to $T_{\text{MAX}}$			0.075			0.03			*	% of FS
$G = 1000$	$T_A = T_{\text{MIN}}$ to $T_{\text{MAX}}$			0.15			0.1			*	% of FS
<b>RATED OUTPUT</b>											
Voltage	$R_L = 10\text{k}\Omega$	$\pm( V_{\text{CC}}  - 2.5)$			*			*			V
Current		$\pm 1$			*			*			mA
Short Circuit Current <sup>(2)</sup>			2			*			*		mA
Output Impedance, $G = 1000$			0.1			*			*		$\Omega$
<b>INPUT</b>											
<b>OFFSET VOLTAGE</b>											
Initial Offset <sup>(3)</sup>	$T_A = +25^\circ\text{C}$			$\pm 300 \pm 300/G$			$\pm 100 \pm 200/G$			*	$\mu\text{V}$
<b>INA102AU</b>										$\pm 500 \pm 300/G$	$\mu\text{V}$
vs Temperature				$\pm 5 \pm 10/G$			$\pm 2 \pm 5/G$			*	$\mu\text{V}/^\circ\text{C}$
vs Supply				$\pm 40 \pm 50/G$			$\pm 10 \pm 20/G$			*	$\mu\text{V}/\text{V}$
vs Time				$\pm(20 + 30/G)$		*			*		$\mu\text{V}/\text{mo}$
<b>BIAS CURRENT</b>											
Initial Bias Current (Each Input)	$T_A = T_{\text{MIN}}$ to $T_{\text{MAX}}$		25	50		6	30		*	*	nA
vs Temperature			$\pm 0.1$			*			*	*	nA/ $^\circ\text{C}$
vs Supply			$\pm 0.1$			*			*	*	nA/V
Initial Offset Current	$T_A = T_{\text{MIN}}$ to $T_{\text{MAX}}$		$\pm 2.5$	$\pm 15$		$\pm 2.5$	$\pm 10$		*	*	nA
vs Temperature			$\pm 0.1$			*			*	*	nA/ $^\circ\text{C}$
<b>IMPEDANCE</b>											
Differential			$10^{10} \parallel 2$			*			*	*	$\Omega \parallel \text{pF}$
Common-Mode			$10^{10} \parallel 2$			*			*	*	$\Omega \parallel \text{pF}$
<b>VOLTAGE RANGE</b>											
Range, Linear Response	$T_A = T_{\text{MIN}}$ to $T_{\text{MAX}}$	$\pm( V_{\text{CC}}  - 4.5)$			*			*			V
CMR With $1\text{k}\Omega$ Source Imbalance											
$G = 1$	DC to 60Hz	80	94		90	*		75	*		dB
$G = 10$	DC to 60Hz	80	100		90	*		*	*		dB
$G = 10$ to 1000	DC to 60Hz	80	100		90	*		*	*		dB
<b>NOISE</b>											
Input Voltage Noise						*			*		$\mu\text{Vp-p}$
$f_B = 0.01\text{Hz}$ to $10\text{Hz}$			1			*			*		nV/ $\sqrt{\text{Hz}}$
Density, $G = 1000$ : $f_O = 10\text{Hz}$			30			*			*		nV/ $\sqrt{\text{Hz}}$
$f_O = 100\text{Hz}$			25			*			*		nV/ $\sqrt{\text{Hz}}$
$f_O = 1\text{kHz}$			25			*			*		nV/ $\sqrt{\text{Hz}}$
Input Current Noise						*			*		pAp-p
$f_B = 0.01\text{Hz}$ to $10\text{Hz}$			25			*			*		pA/ $\sqrt{\text{Hz}}$
Density: $f_O = 10\text{Hz}$			0.3			*			*		pA/ $\sqrt{\text{Hz}}$
$f_O = 100\text{Hz}$			0.2			*			*		pA/ $\sqrt{\text{Hz}}$
$f_O = 1\text{kHz}$			0.15			*			*		pA/ $\sqrt{\text{Hz}}$

## ELECTRICAL (CONT)

PARAMETER	CONDITIONS	INA102AG			INA102CG			INA102KP/INA102AU			UNITS
		MIN	TYP	MAX	MIN	TYP	MAX	MIN	TYP	MAX	
<b>DYNAMIC RESPONSE</b>											
Small Signal, ±3dB Flatness G = 1 G = 10 G = 100 G = 1000	$V_{OUT} = 0.1V_{rms}$		300			*			*		kHz
			30			*			*		kHz
			3			*			*		kHz
			0.3			*			*		kHz
Small Signal, ±1% Flatness G = 1 G = 10 G = 100 G = 1000 Full Power, G = 1 to 100 Slew Rate, G = 1 to 100 Settling Time 0.1%: G = 1 G = 100 G = 1000 0.01%: G = 1 G = 100 G = 1000	$V_{OUT} = 0.1V_{rms}$		30			*			*		kHz
			3			*			*		kHz
			0.3			*			*		kHz
			0.03			*			*		kHz
	$V_{OUT} = 10V, R_L = 10k\Omega$ $V_{OUT} = 10V, R_L = 10k\Omega$ $R_L = 10k\Omega, C_L = 100pF$	1.7	2.5		*	*		*	*		kHz
		0.1	0.15		*	*		*	*		V/μs
	10V Step		50			*			*		μs
			360			*			*		μs
			3300			*			*		μs
			60			*			*		μs
10V Step		500			*			*		μs	
		4500			*			*		μs	
<b>POWER SUPPLY</b>											
Rated Voltage	$V_O = 0V,$ $T_A = T_{MIN} \text{ to } T_{MAX}$	±3.5	±15	±18	*	*	*	*	*	*	V
Voltage Range											V
Quiescent Current			±500	±750	*	*	*	*	*	*	μA
<b>TEMPERATURE RANGE</b>											
Specification	$R_L > 50k\Omega^{(2)}$	-25		+85	*		*	0		+70	°C
INA102AU		-25		+85	*		*	-25		+85	°C
Operation		-65		+150	*		*	-55		+125	°C
Storage											°C

\*Specification same as for INA102AG.

NOTES: (1) The internal gain set resistors have an absolute tolerance of ±20%; however, their tracking is 50ppm/°C.  $R_G$  will add to the gain error if gains other than 1, 10, 100, or 1000 are set externally. (2) At high temperature, output drive current is limited. An external buffer can be used if required. (3) Adjustable to zero.

## PIN CONFIGURATION

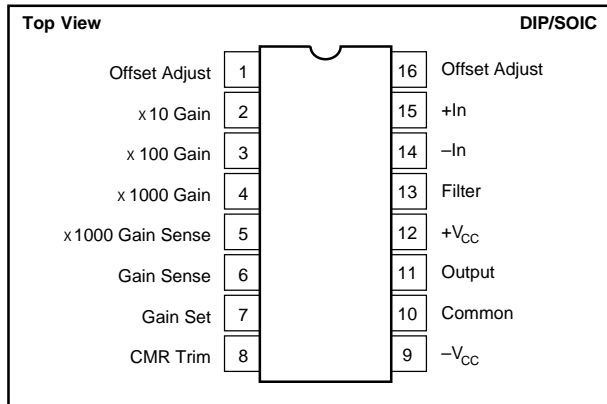

## ABSOLUTE MAXIMUM RATINGS

Supply .....	±18V
Input Voltage Range .....	± $V_{CC}$
Operating Temperature Range .....	-25°C to +85°C
Storage Temperature Range: Ceramic .....	-65°C to +150°C
Plastic, SOIC .....	-55°C to +125°C
Lead Temperature (soldering, 10s) .....	+300°C
Output Short Circuit Duration .....	Continuous to Ground

## PACKAGE INFORMATION

PRODUCT	PACKAGE	PACKAGE DRAWING NUMBER <sup>(1)</sup>
INA102AG	16-Pin Ceramic DIP	109
INA102CG	16-Pin Ceramic DIP	109
INA102KP	16-Pin Plastic DIP	180
INA102AU	16-Pin SOIC	211

NOTE: (1) For detailed drawing and dimension table, please see end of data sheet, or Appendix C of Burr-Brown IC Data Book.

## ORDERING INFORMATION

PRODUCT	PACKAGE	TEMPERATURE RANGE
INA102AG	16-Pin Ceramic DIP	-25°C to +85°C
INA102CG	16-Pin Ceramic DIP	-25°C to +85°C
INA102KP	16-Pin Plastic DIP	0°C to +70°C
INA102AU	16-Pin Plastic SOIC	-25°C to +85°C

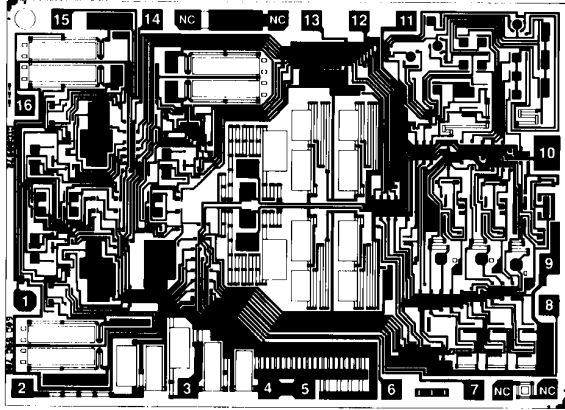

INA102 DIE TOPOGRAPHY

PAD	FUNCTION	PAD	FUNCTION
1	Offset Adjust	10*	Common
2	X10 Gain	11	Output
3	X100 Gain	12	+V <sub>CC</sub>
4	X1000 Gain	13	Filter
5	X1000 Gain Sense	14	-In
6	Gain Sense	15	+In
7	Gain Set	16	Offset Adjust
8	CMR Trim	17	(A <sub>1</sub> Output)
9	-V <sub>CC</sub>	18	(A <sub>2</sub> Output)

\* Glass covers upper one-third of this pad.

Substrate Bias: Electrically connected to -V supply.

NC: No Connection.

### MECHANICAL INFORMATION

	MILS (0.001")	MILLIMETERS
Die Size	142 x 104 ±5	3.61 x 2.64 ±0.13
Die Thickness	20 ±3	0.51 ±0.08
Min. Pad Size	4 x 4	0.10 x 0.10
Backing	Gold	

## TYPICAL PERFORMANCE CURVES

At +25°C and in circuit of Figure 2 unless otherwise noted.

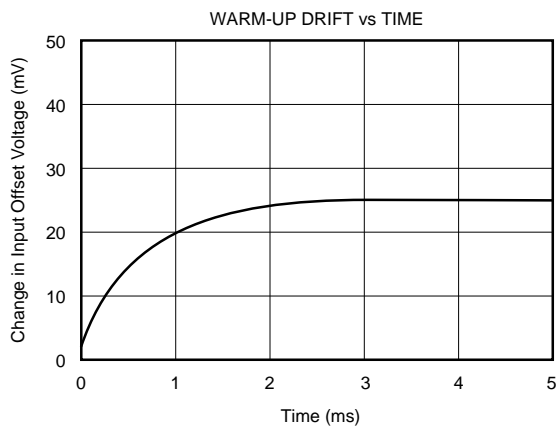
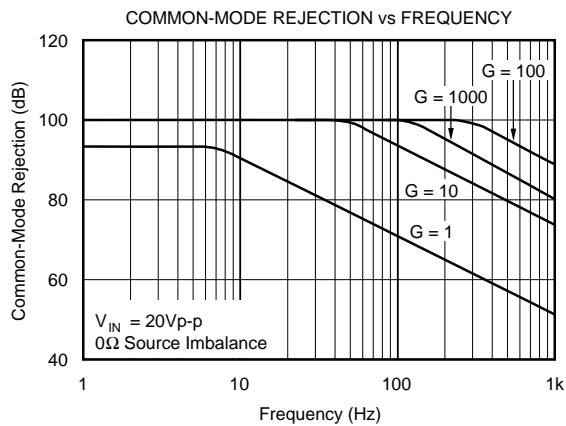
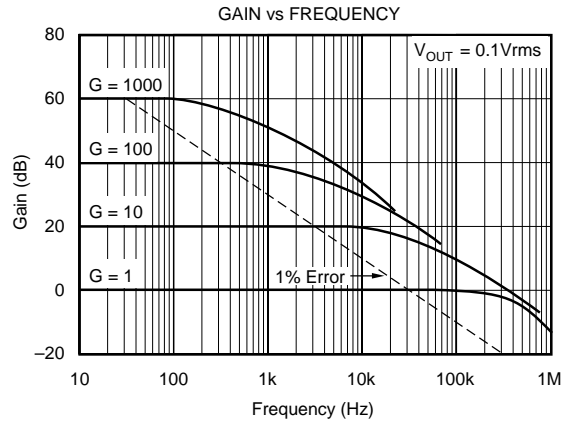
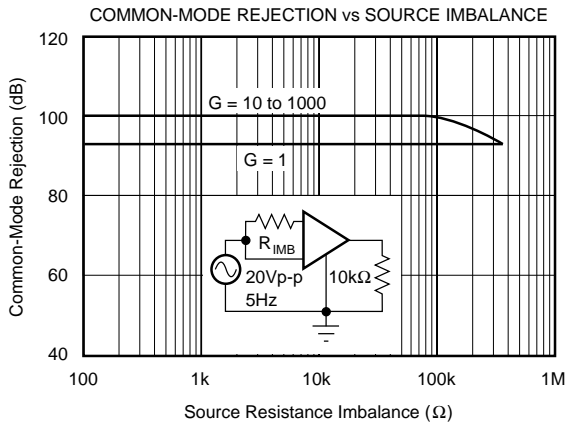

# TYPICAL PERFORMANCE CURVES (CONT)

At +25°C and in circuit of Figure 2 unless otherwise noted.

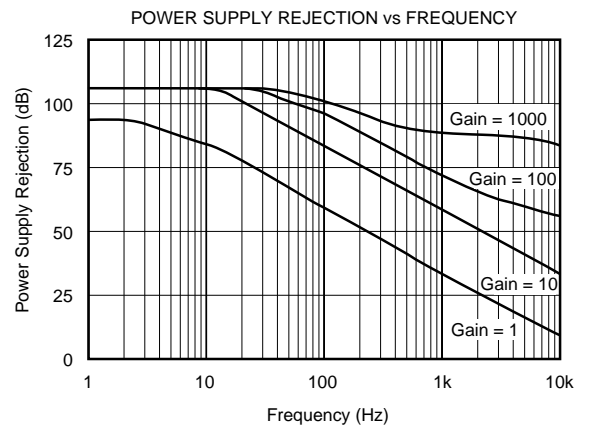
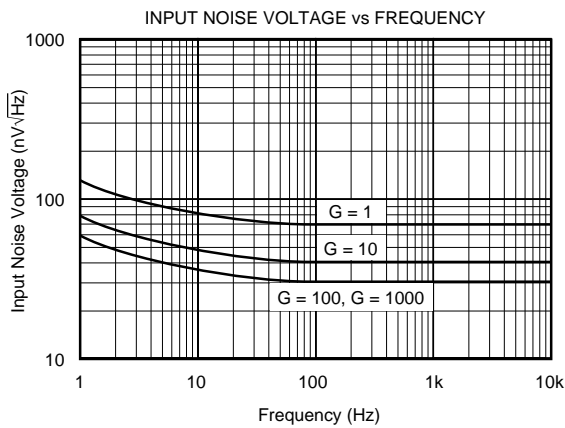
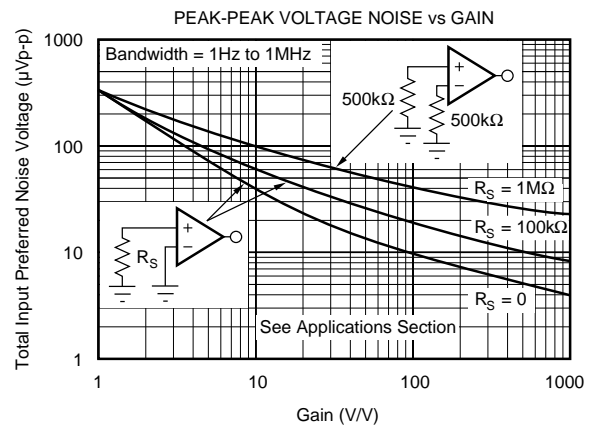
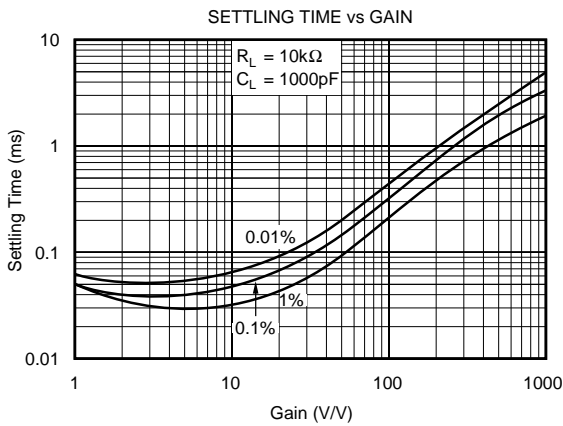
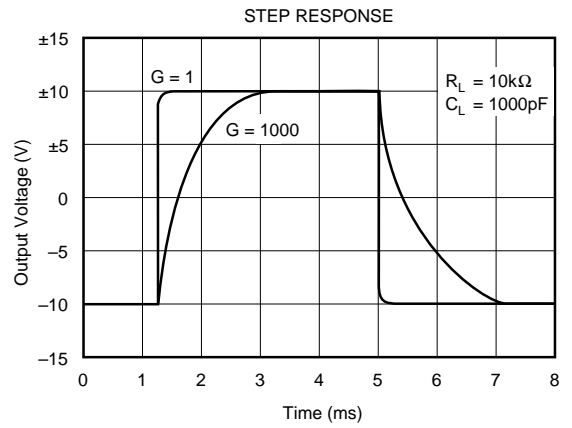
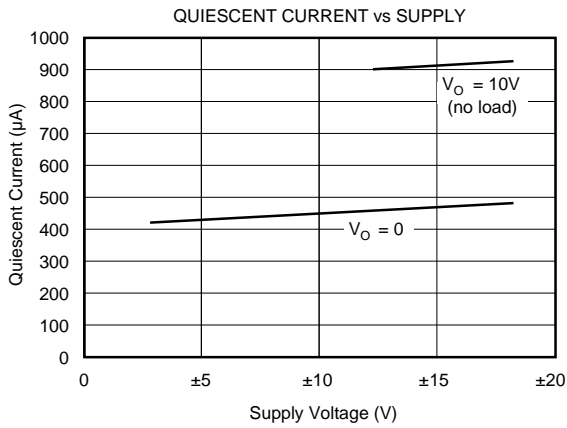

# DISCUSSION OF PERFORMANCE

## INSTRUMENTATION AMPLIFIERS

Instrumentation amplifiers are differential-input closed-loop gain blocks whose committed circuit accurately amplifies the voltage applied to their inputs. They respond mainly to the difference between the two input signals and exhibit extremely high input impedance, both differentially and common-mode. The feedback networks of this instrumentation amplifier are included on the monolithic chip. No external resistors are required for gains of 1, 10, 100, and 1000 in the INA102.

An operational amplifier, on the other hand, is an open-loop, uncommitted device that requires external networks to close the loop. While op amps can be used to achieve the same basic function as instrumentation amplifiers, it is very difficult to reach the same level of performance. Using op amps often leads to design tradeoffs when it is necessary to amplify low-level signals in the presence of common-mode voltages while maintaining high-input impedances. Figure 1 shows a simplified model of an instrumentation amplifier that eliminates most of the problems associated with op amps.

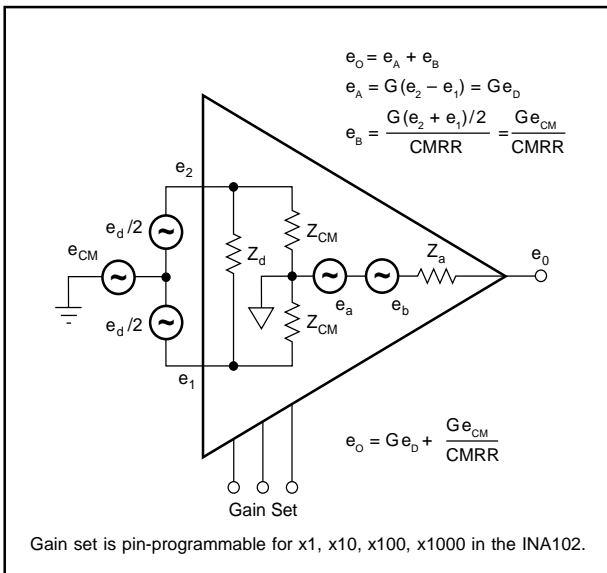

FIGURE 1. Model of an Instrumentation Amplifier.

## THE INA102

A simplified schematic of the INA102 is shown on the first page. A three-amplifier configuration is used to provide the desirable characteristics of a premium performance instrumentation amplifier. In addition, INA102 has features not normally found in integrated circuit instrumentation amplifiers.

The input buffers ( $A_1$  and  $A_2$ ) incorporate high performance, low-drift amplifier circuitry. The amplifiers are connected in the noninverting configuration to provide the high input

impedance ( $10^{10}\Omega$ ) desirable in instrumentation amplifier applications. The offset voltage, and offset voltage versus temperature, are low due to the monolithic design, and improved even further by state-of-the-art laser-trimming techniques.

The output stage ( $A_3$ ) is connected in a unity-gain differential amplifier configuration. A critical part of this stage is the matching of the four  $20k\Omega$  resistors which provide the difference function. These resistors must be initially well matched and the matching must be maintained over temperature and time in order to retain good common-mode rejection.

All of the internal resistors are made of thin-film nichrome on the integrated circuit. The critical resistors are laser-trimmed to provide the desired high gain accuracy and common-mode rejection. Nichrome ensures long-term stability and provides excellent TCR and TCR tracking. This provides gain accuracy and common-mode rejection when the INA102 is operated over wide temperature ranges.

## USING THE INA102

Figure 2 shows the simplest configuration of the INA102. The output voltage is a function of the differential input voltage times the gain.

A gain of 1, 10, 100, or 1000 is selected by programming pins 2 through 7 (see Table I). Notice that for the gain of 1000, a special gain sense is provided to preserve accuracy. Although this is not always required, gain errors caused by external resistance in series with the low value  $40.04\Omega$  internal gain set resistor are thus eliminated.

GAIN	CONNECT PINS
1	6 to 7
10	2 to 6 and 7
100	3 to 6 and 7
1000	4 to 7 and separately 5 to 6

TABLE I. Pin-Programmable Gain Connections.

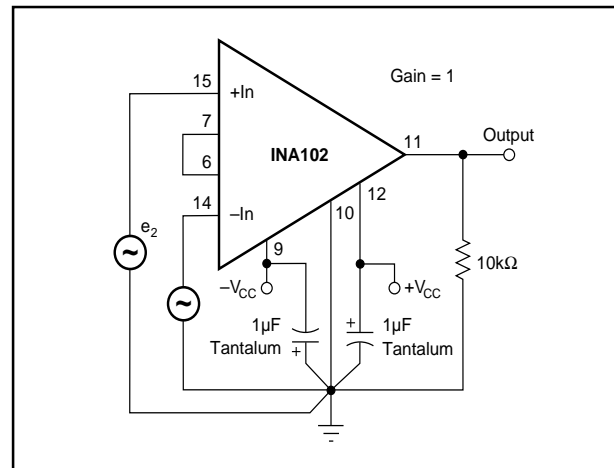

FIGURE 2. Basic Circuit Connection for the INA102.

Other gains between 1 and 10, 10 and 100, and 100 and 1000 can also be obtained by connecting an external resistor between pin 6 and either pin 2, 3, or 4, respectively (see Figure 6 for application).

$G = 1 + (40/R_G)$  where  $R_G$  is the total resistance between the two inverting inputs of the input op amps. At high gains, where the value of  $R_G$  becomes small, additional resistance (i.e., relays or sockets) in the  $R_G$  circuit will contribute to a gain error. Care should be taken to minimize this effect.

### OPTIONAL OFFSET ADJUSTMENT PROCEDURE

It is sometimes desirable to null the input and/or output offset to achieve higher accuracy. The quality of the potentiometer will affect the results; therefore, choose one with good temperature and mechanical-resistance stability.

The optional offset null capabilities are shown in Figure 3.  $R_4$  adjustment affects only the input stage component of the offset voltage. Note that the null condition will be disturbed when the gain is changed. Also, the input drift will be affected by approximately  $0.31\mu\text{V}/^\circ\text{C}$  per  $100\mu\text{V}$  of input offset voltage that is trimmed. Therefore, care should be taken when considering use of the control for removal of other sources of offset. Output offset correction can be accomplished with  $A_1$ ,  $R_1$ ,  $R_2$ , and  $R_3$ , by applying a voltage to Common (pin 10) through a buffer amplifier. This buffer limits the resistance in series with pin 10 to minimize CMR error. Resistance above  $0.1\Omega$  will cause the common-mode rejection to fall below 100dB. Be certain to keep this resistance low.

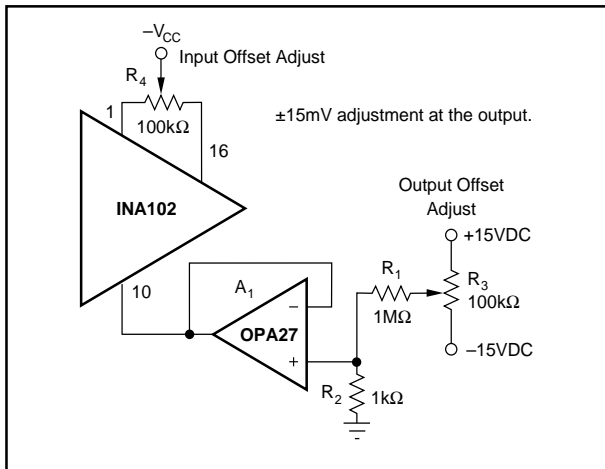

FIGURE 3. Optional Offset Nulling.

It is important to not exceed the input amplifiers' dynamic range. The amplified differential input signal and its associated common-mode voltage should not cause the output of  $A_1$  or  $A_2$  to exceed approximately  $\pm 12\text{V}$  with  $\pm 15\text{V}$  supplies, or nonlinear operation will result. To protect against moisture, especially in high gain, sealing compound may be used. Current injected into the offset pins should be minimized.

### OPTIONAL FILTERING

The INA102 has provisions for accomplishing filtering with one external capacitor between pins 11 and 13. This single-pole filter can be used to reduce noise outside the signal bandwidth, but with some degradation to AC CMR.

When it is important to preserve CMR versus frequency (especially at 60Hz), two capacitors should be used. The additional capacitor is connected between pins 8 and 10. This will maintain a balance of impedances in the output stage. Either of these capacitors could also be trimmed slightly, to maximize CMR, if desired. Note that their ratio tracking will affect CMR over temperature.

### OPTIONAL COMMON-MODE REJECTION TRIM

The INA102 is laser-adjusted during manufacturing to assure high CMR. However, if desired, a small resistance can be added in series with pin 10 to trim the CMR to an improved level. Depending upon the nature of the internal imbalances, either positive or negative resistance value could be required. The circuit shown in Figure 4 acts as a bipolar potentiometer and allows easy adjustment of CMR.

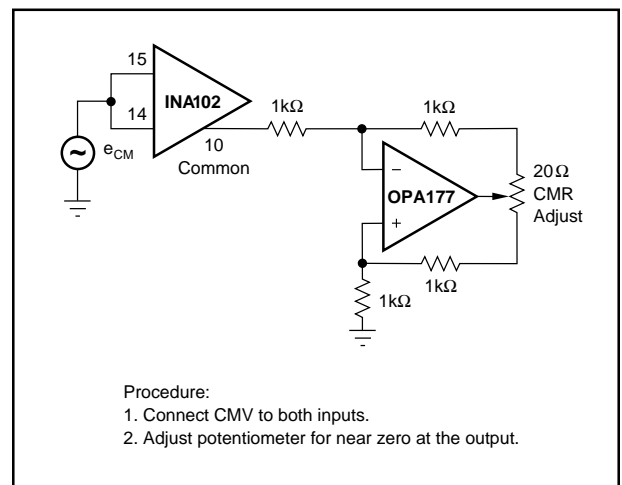

FIGURE 4. Optional Circuit for Externally Trimming CMR.

## TYPICAL APPLICATIONS

Many applications of instrumentation amplifiers involve the amplification of low-level differential signals from bridges and transducers such as strain gages, thermocouples, and RTDs. Some of the important parameters include common-mode rejection (differential cancellation of common-mode offset and noise, see Figure 1), input impedance, offset voltage and drift, gain accuracy, linearity, and noise. The INA102 accomplishes all of these with high precision at surprisingly low quiescent current. However, in higher gains ( $>100$ ), the bias current can cause a large offset error at the output. This can saturate the output unless the source impedance is separated, e.g., two  $500\text{k}\Omega$  paths instead of one  $1\text{M}\Omega$  unbalanced input. Figures 5 through 16 show some typical applications circuits.

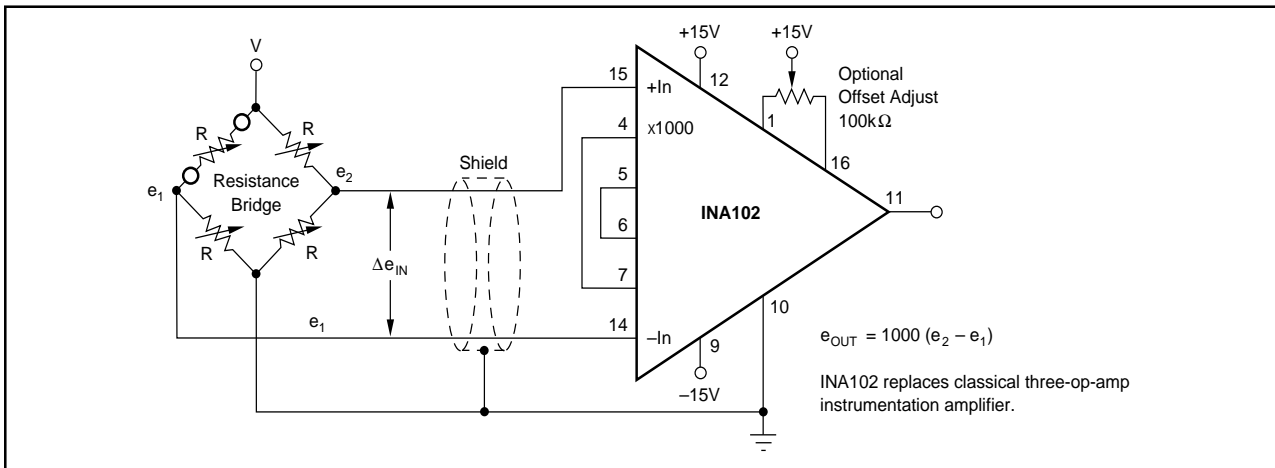

FIGURE 5. Amplification of a Differential Voltage from a Resistance Bridge.

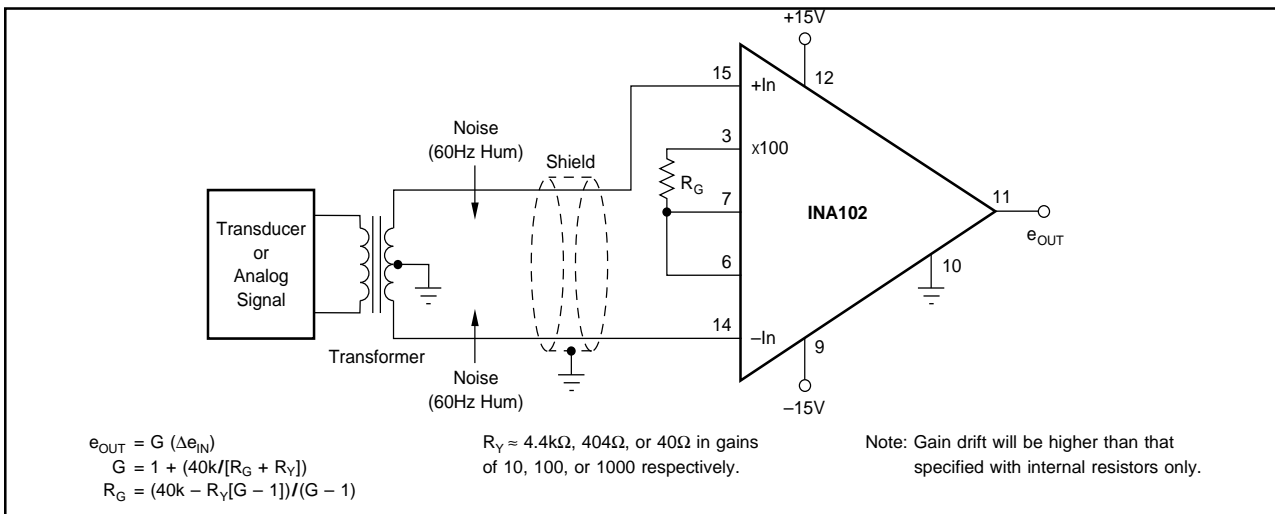

FIGURE 6. Amplification of a Transformer-Coupled Analog Signal Using External Gain Set.

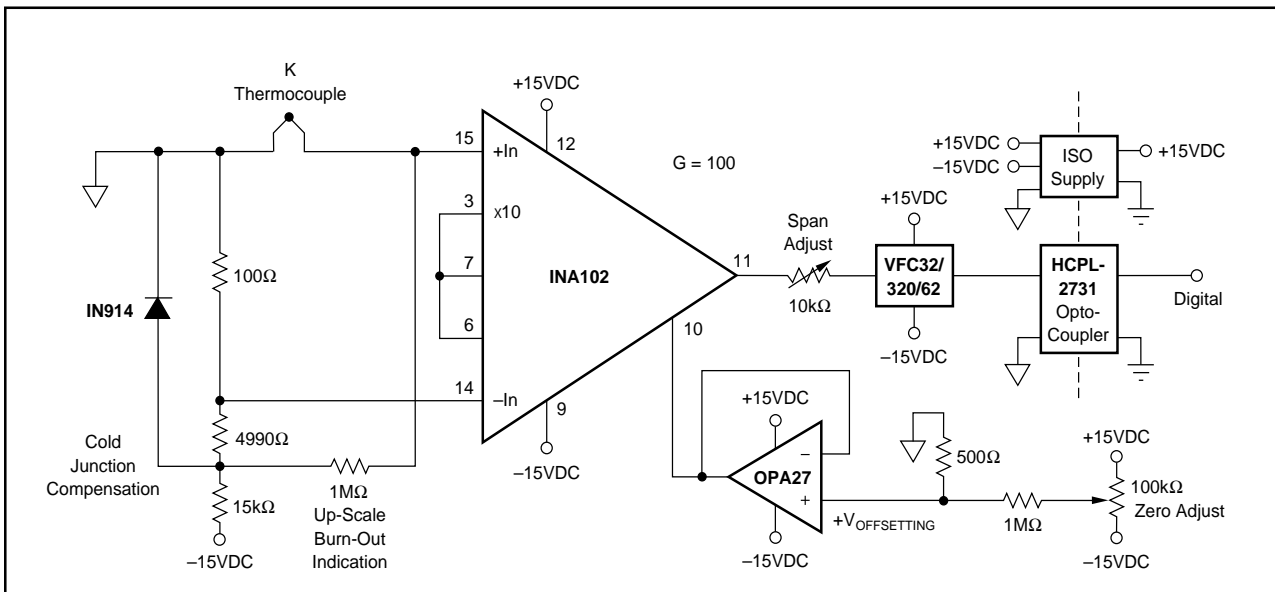

FIGURE 7. Isolated Thermocouple Amplifier with Cold Junction Compensation.

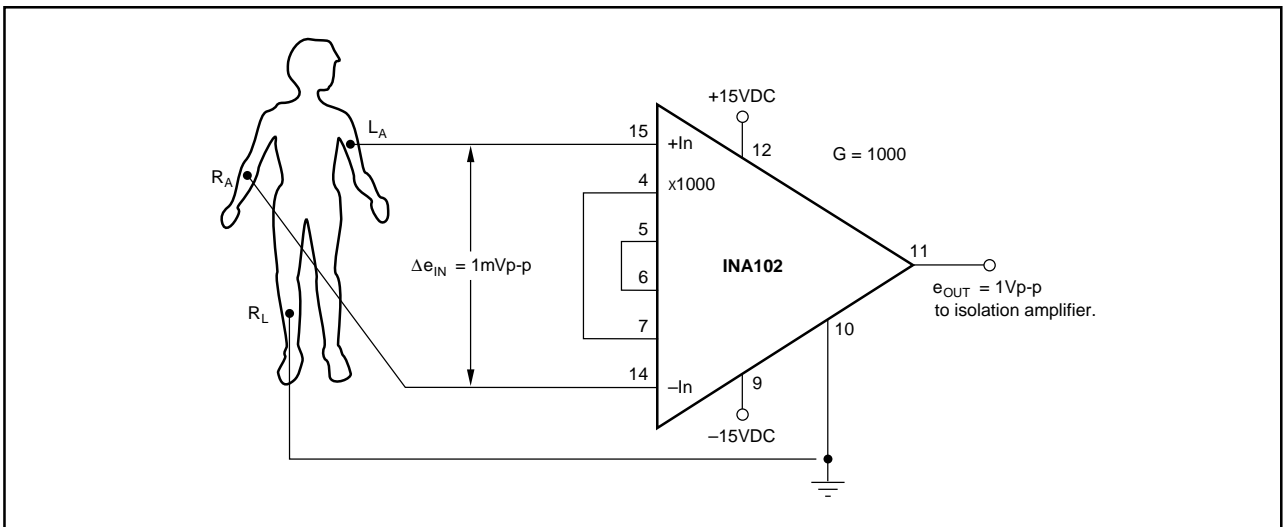

FIGURE 8. ECG Amplifier or Recorder Preamp for Biological Signals.

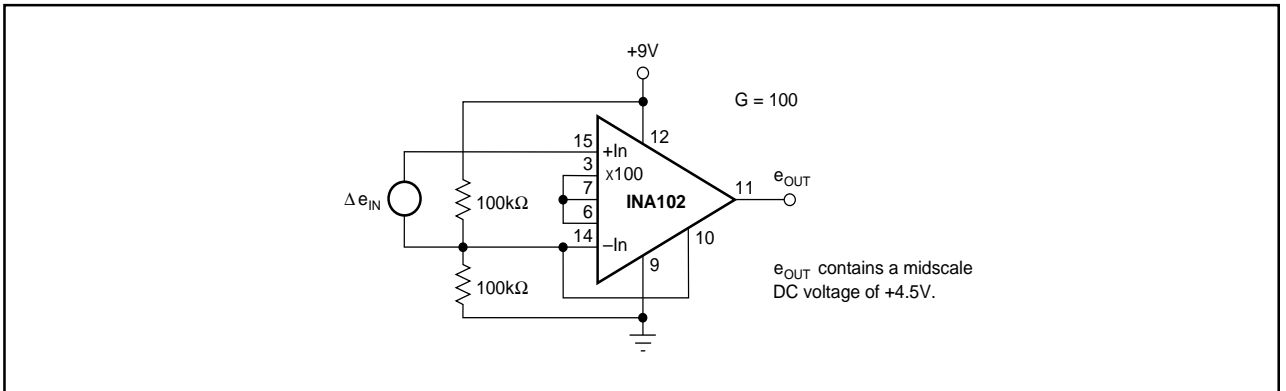

FIGURE 9. Single Supply Low Power Instrumentation Amplifier.

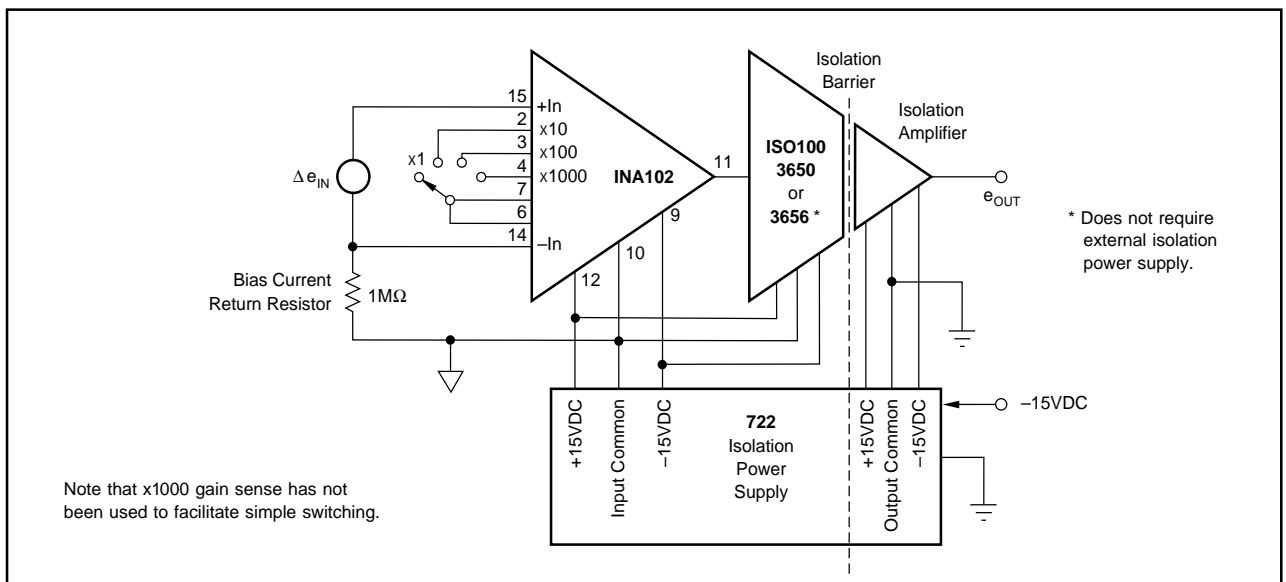

FIGURE 10. Precision Isolated Instrumentation Amplifier.

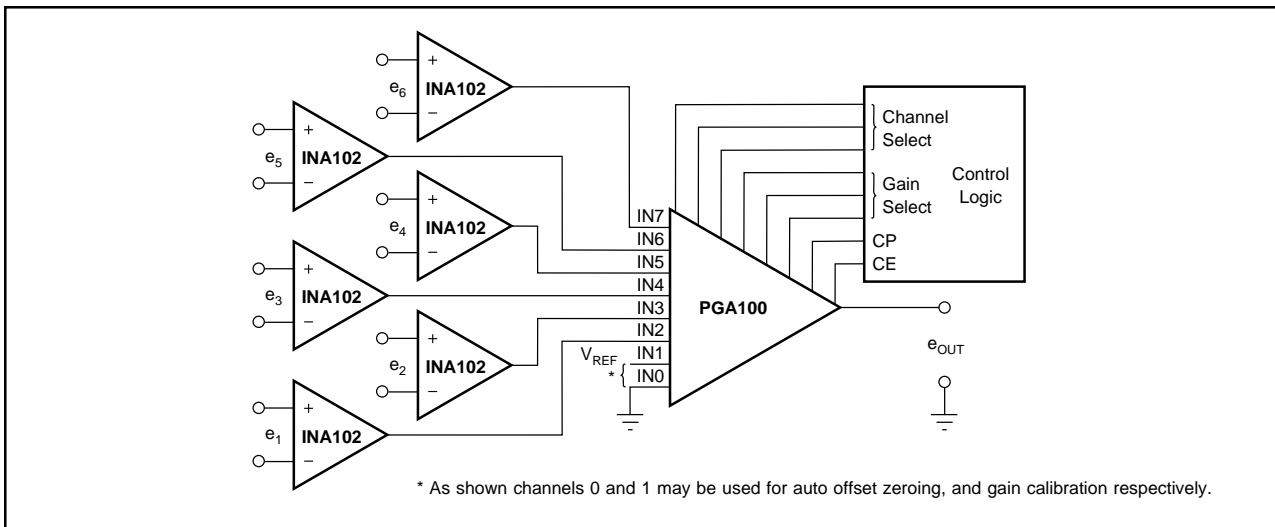

FIGURE 11. Multiple Channel Precision Instrumentation Amplifier with Programmable Gain.

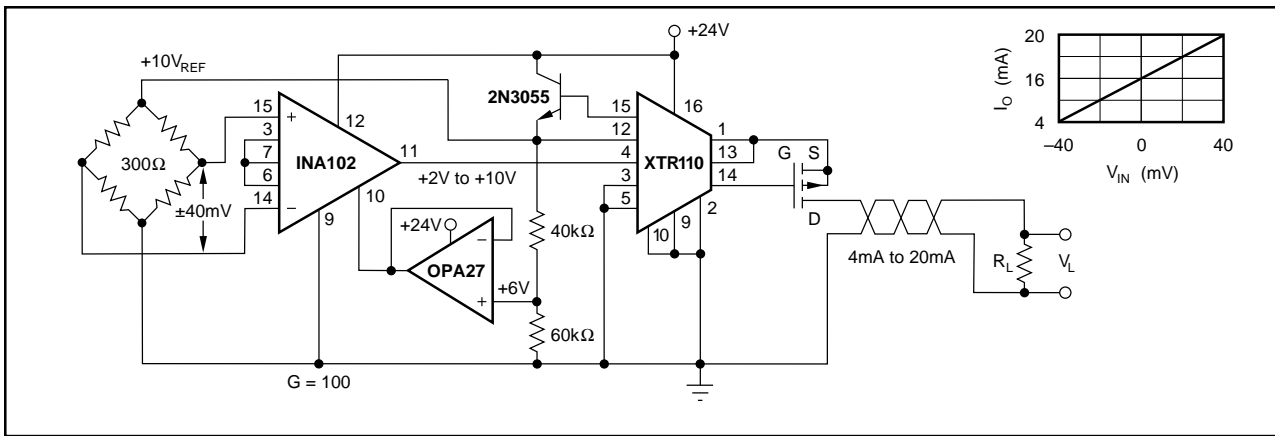

FIGURE 12. 4mA to 20mA Bridge Transmitter Using Single Supply Instrumentation Amplifier.

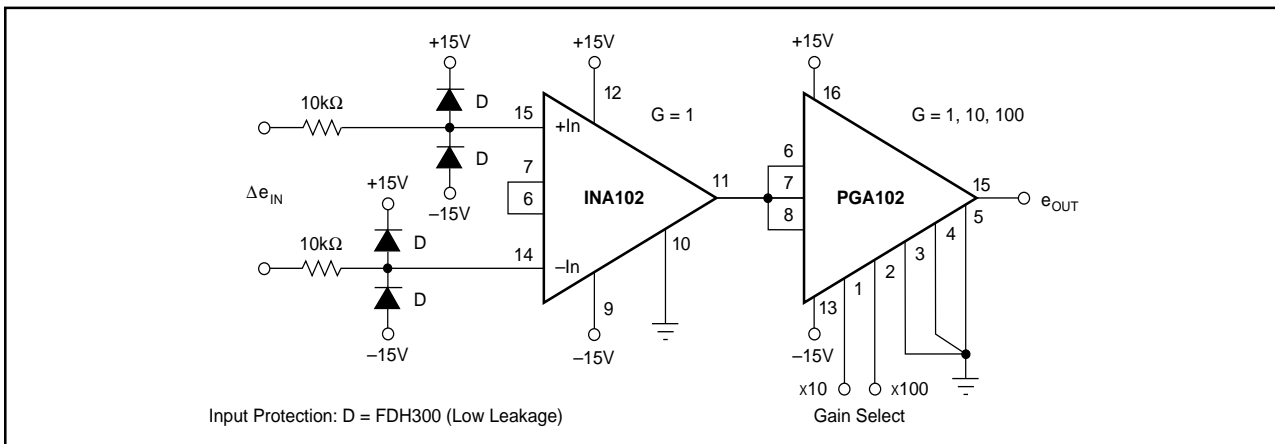

FIGURE 13. Programmable-Gain Instrumentation Amplifier Using the INA102 and PGA102.

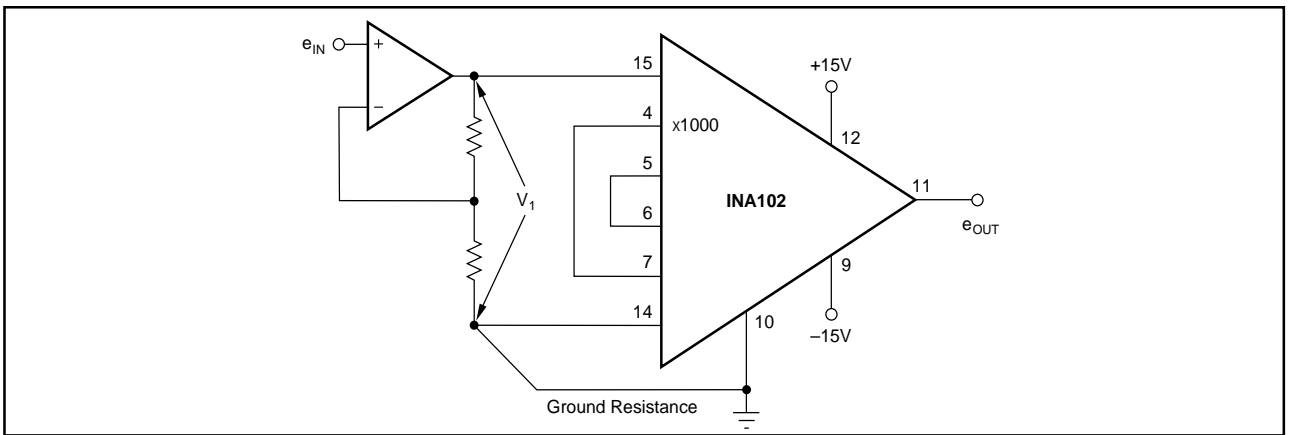

FIGURE 14. Ground Resistance Loop Eliminator (INA102 senses and amplifies  $V_1$  accurately).

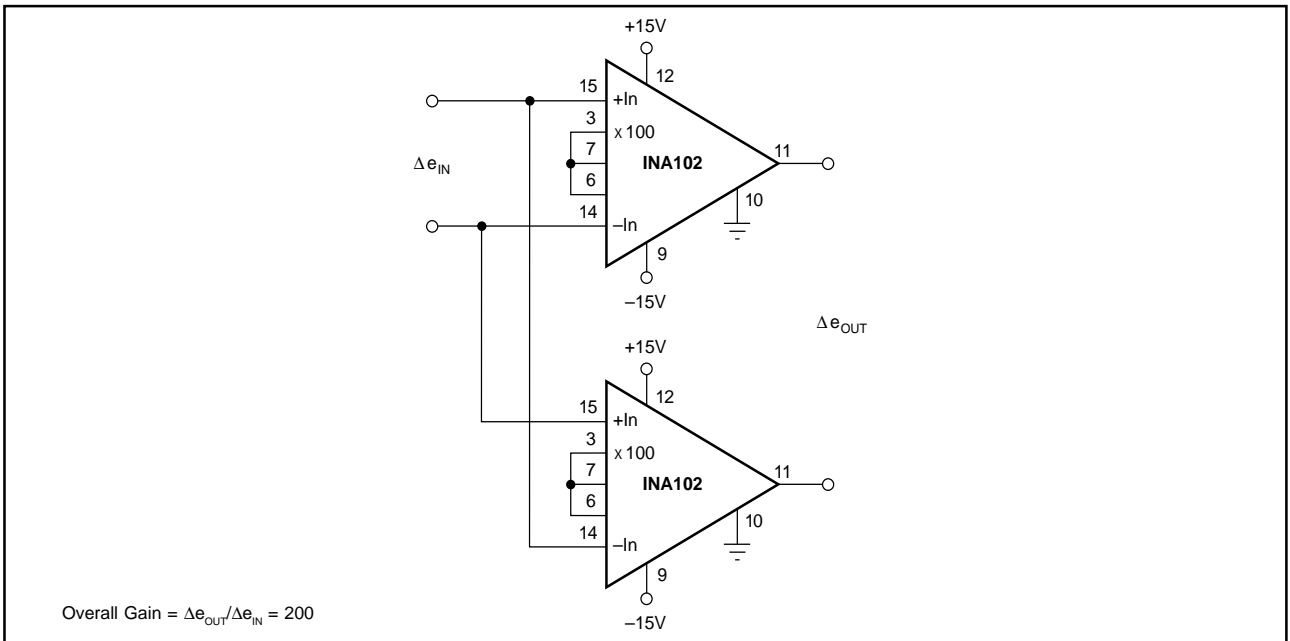

FIGURE 15. Differential Input/Differential Output Amplifier (twice the gain of one INA).

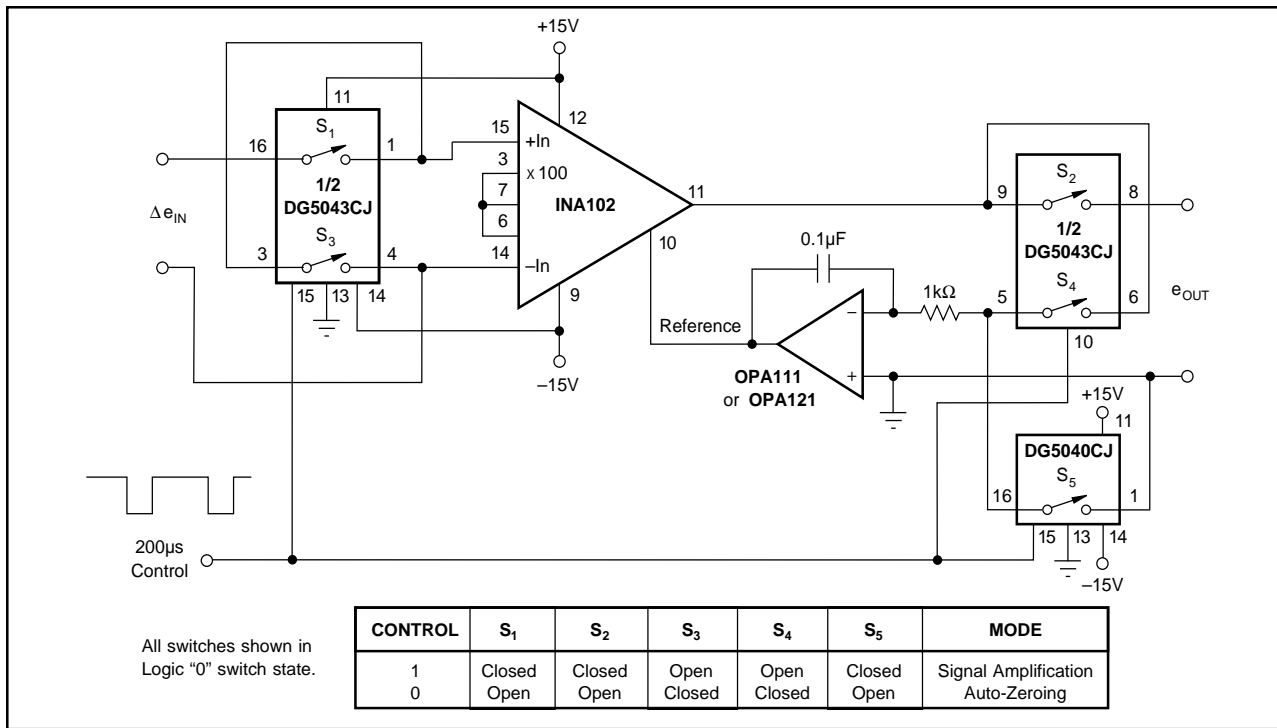

FIGURE 16. Auto-Zeroing Instrumentation Amplifier Circuit.

The information provided herein is believed to be reliable; however, BURR-BROWN assumes no responsibility for inaccuracies or omissions. BURR-BROWN assumes no responsibility for the use of this information, and all use of such information shall be entirely at the user's own risk. Prices and specifications are subject to change without notice. No patent rights or licenses to any of the circuits described herein are implied or granted to any third party. BURR-BROWN does not authorize or warrant any BURR-BROWN product for use in life support devices and/or systems.

## **IMPORTANT NOTICE**

Texas Instruments and its subsidiaries (TI) reserve the right to make changes to their products or to discontinue any product or service without notice, and advise customers to obtain the latest version of relevant information to verify, before placing orders, that information being relied on is current and complete. All products are sold subject to the terms and conditions of sale supplied at the time of order acknowledgment, including those pertaining to warranty, patent infringement, and limitation of liability.

TI warrants performance of its semiconductor products to the specifications applicable at the time of sale in accordance with TI's standard warranty. Testing and other quality control techniques are utilized to the extent TI deems necessary to support this warranty. Specific testing of all parameters of each device is not necessarily performed, except those mandated by government requirements.

Customers are responsible for their applications using TI components.

In order to minimize risks associated with the customer's applications, adequate design and operating safeguards must be provided by the customer to minimize inherent or procedural hazards.

TI assumes no liability for applications assistance or customer product design. TI does not warrant or represent that any license, either express or implied, is granted under any patent right, copyright, mask work right, or other intellectual property right of TI covering or relating to any combination, machine, or process in which such semiconductor products or services might be or are used. TI's publication of information regarding any third party's products or services does not constitute TI's approval, warranty or endorsement thereof.

This datasheet has been downloaded from:

[www.DatasheetCatalog.com](http://www.DatasheetCatalog.com)

Datasheets for electronic components.



LittleDiode supplies new, hard to find or obsolete electronic components and semiconductors all over the world.

With over two million different components listed you are sure to find the part you need.

Feel free to visit us today at our online store:

[LittleDiode.com](http://LittleDiode.com)

Looking forward to providing you with the best possible service.