

# BB404M

## Build in Biasing Circuit MOS FET IC UHF/VHF RF Amplifier

# HITACHI

ADE-208-717A (Z)  
2nd. Edition  
Dec. 1998

### Features

- Build in Biasing Circuit; To reduce using parts cost & PC board space.
- High gain;  
(PG = 29 dB typ. at f = 200 MHz)
- Low noise characteristics;  
(NF = 1.2 dB typ. at f = 200 MHz)
- Wide supply voltage range;  
Applicable with 5V to 9V supply voltage.
- Withstanding to ESD;  
Build in ESD absorbing diode. Withstand up to 200V at C=200pF, Rs=0 conditions.
- Provide mini mold packages; MPAK-4R(SOT-143 var.)

### Outline

MPAK-4R

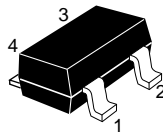

1. Source
2. Drain
3. Gate2
4. Gate1

Notes: 1. Marking is "DX-".

2. BB404M is individual type number of HITACHI BBFET.

## Absolute Maximum Ratings (Ta = 25°C)

Item	Symbol	Ratings	Unit
Drain to source voltage	$V_{DS}$	12	V
Gate1 to source voltage	$V_{G1S}$	$\pm 10$ - 0	V
Gate2 to source voltage	$V_{G2S}$	$\pm 10$	V
Drain current	$I_D$	25	mA
Channel power dissipation	Pch	150	mW
Channel temperature	Tch	150	°C
Storage temperature	Tstg	-55 to +150	°C

## Electrical Characteristics (Ta = 25°C)

Item	Symbol	Min	Typ	Max	Unit	Test Conditions
Drain to source breakdown voltage	$V_{(BR)DSS}$	12	—	—	V	$I_D = 200\mu A, V_{G1S} = V_{G2S} = 0$
Gate1 to source breakdown voltage	$V_{(BR)G1SS}$	+10	—	—	V	$I_{G1} = +10\mu A, V_{G2S} = V_{DS} = 0$
Gate2 to source breakdown voltage	$V_{(BR)G2SS}$	$\pm 10$	—	—	V	$I_{G2} = \pm 10\mu A, V_{G1S} = V_{DS} = 0$
Gate1 to source cutoff current	$I_{G1SS}$	—	—	+100	nA	$V_{G1S} = +9V, V_{G2S} = V_{DS} = 0$
Gate2 to source cutoff current	$I_{G2SS}$	—	—	$\pm 100$	nA	$V_{G2S} = \pm 9V, V_{G1S} = V_{DS} = 0$
Gate1 to source cutoff voltage	$V_{G1S(off)}$	0.4	0.7	1.0	V	$V_{DS} = 5V, V_{G2S} = 4V, I_D = 100\mu A$
Gate2 to source cutoff voltage	$V_{G2S(off)}$	0.5	0.7	1.0	V	$V_{DS} = 5V, V_{G1S} = 5V, I_D = 100\mu A$
Input capacitance	$C_{iss}$	2.3	2.8	3.6	pF	$V_{DS} = 5V, V_{G1} = 5V$
Output capacitance	$C_{oss}$	0.9	1.3	2.0	pF	$V_{G2S} = 4V, R_G = 180k\Omega$
Reverse transfer capacitance	$C_{rss}$	0.003	0.02	0.05	pF	$f = 1MHz$
Drain current	$I_{D(op) 1}$	9	15	19	mA	$V_{DS} = 5V, V_{G1} = 5V$ $V_{G2S} = 4V, R_G = 180k\Omega$
	$I_{D(op) 2}$	—	13	—	mA	$V_{DS} = 9V, V_{G1} = 9V$ $V_{G2S} = 6V, R_G = 470k\Omega$
Forward transfer admittance	$ y_{fs} 1$	22	27	34	mS	$V_{DS} = 5V, V_{G1} = 5V, V_{G2S} = 4V$ $R_G = 180k\Omega, f = 1kHz$
	$ y_{fs} 2$	—	27	—	mS	$V_{DS} = 9V, V_{G1} = 9V, V_{G2S} = 6V$ $R_G = 470k\Omega, f = 1kHz$
Power gain	PG1	24	29	32	dB	$V_{DS} = 5V, V_{G1} = 5V, V_{G2S} = 4V$ $R_G = 180k\Omega, f = 200MHz$
	PG2	—	29	—	dB	$V_{DS} = 9V, V_{G1} = 9V, V_{G2S} = 6V$ $R_G = 470k\Omega, f = 200MHz$
Noise figure	NF1	—	1.2	1.9	dB	$V_{DS} = 5V, V_{G1} = 5V, V_{G2S} = 4V$ $R_G = 180k\Omega, f = 200MHz$
	NF2	—	1.2	—	dB	$V_{DS} = 9V, V_{G1} = 9V, V_{G2S} = 6V$ $R_G = 470k\Omega, f = 200MHz$

Main Characteristics

Test Circuit for Operating Items ( $I_{D(op)}$ ,  $|y_{fs}|$ ,  $C_{iss}$ ,  $C_{oss}$ ,  $C_{rss}$ , NF, PG)

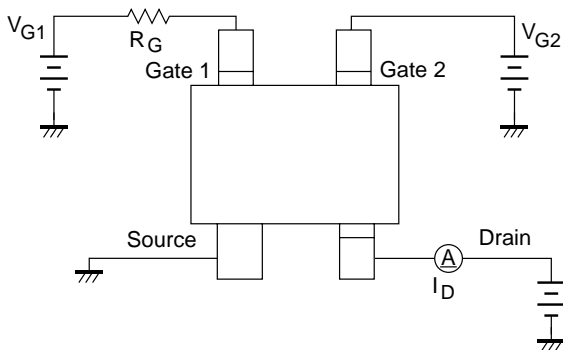

Power Gain, Noise Figure Test Circuit

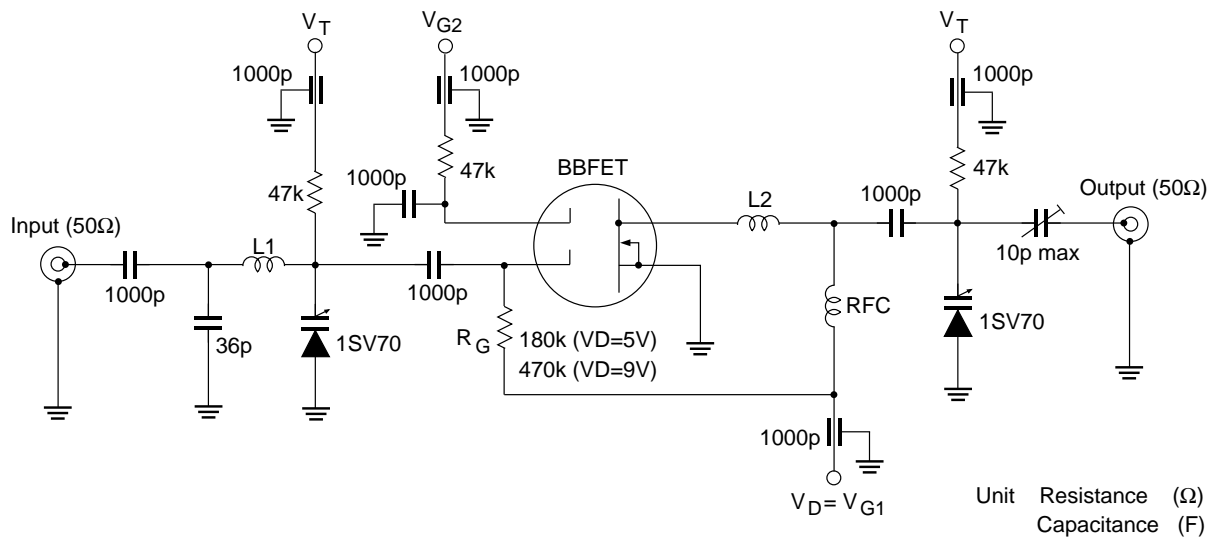

- L1 :  $\phi$ 1mm Enameled Copper Wire, Inside dia 10mm, 2Turns
- L2 :  $\phi$ 1mm Enameled Copper Wire, Inside dia 10mm, 2Turns
- RFC :  $\phi$ 1mm Enameled Copper Wire, Inside dia 5mm, 2Turns

Maximum Channel Power Dissipation Curve

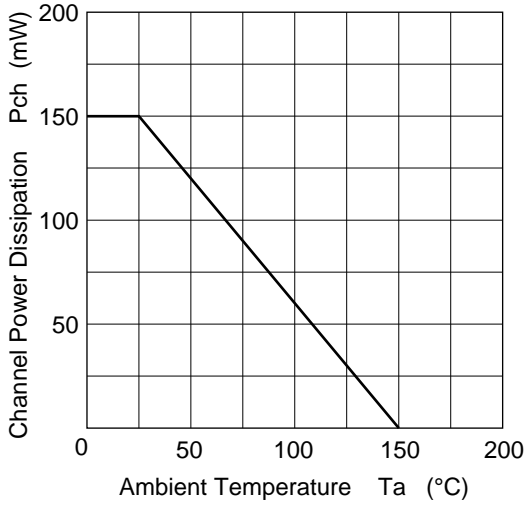

Typical Output Characteristics

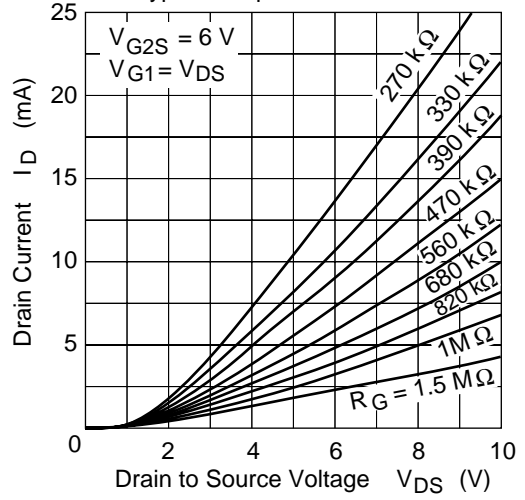

Drain Current vs. Gate2 to Source Voltage

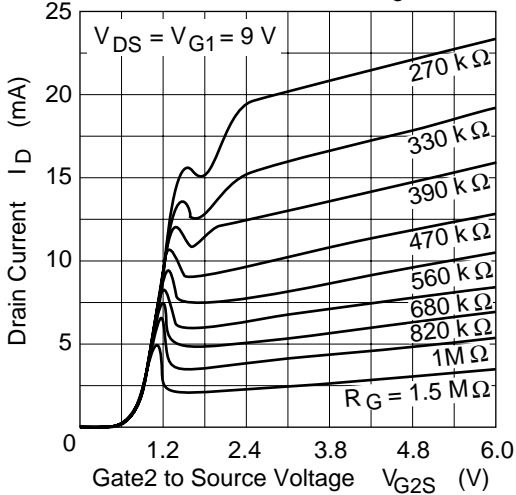

Drain Current vs. Gate1 Voltage

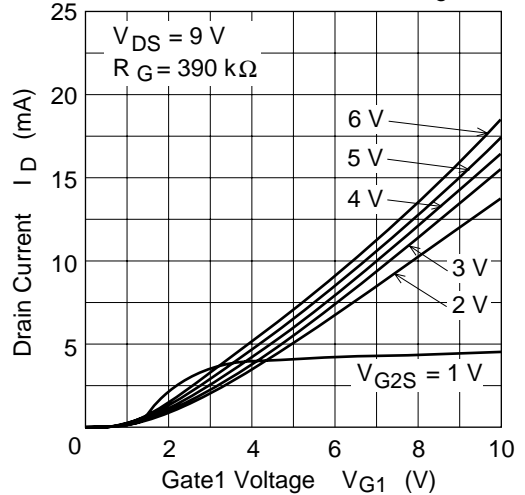

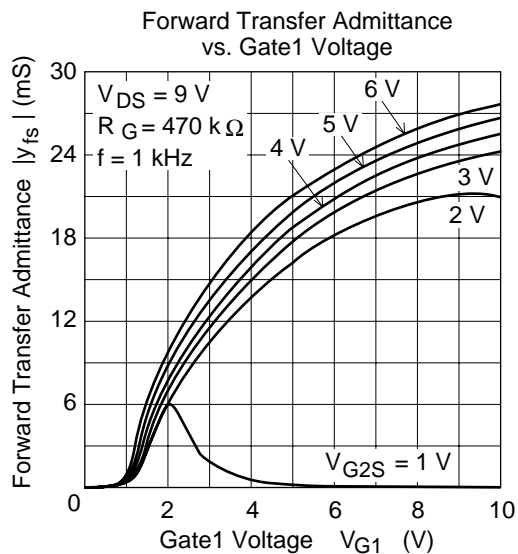
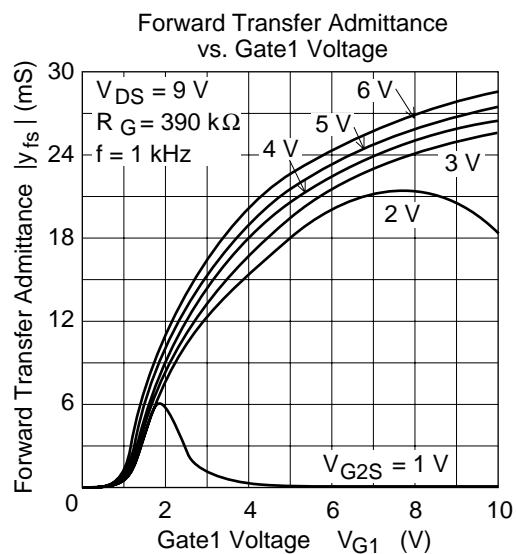
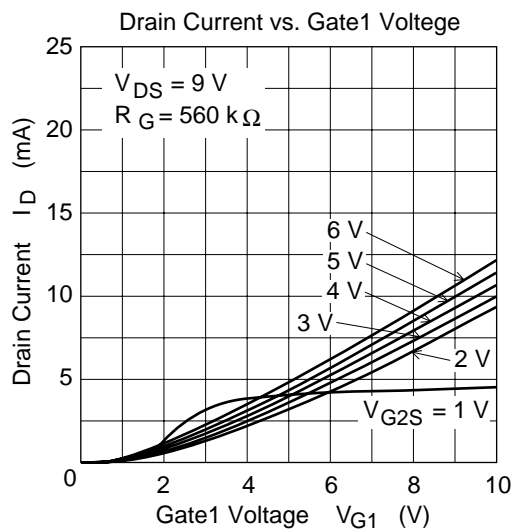
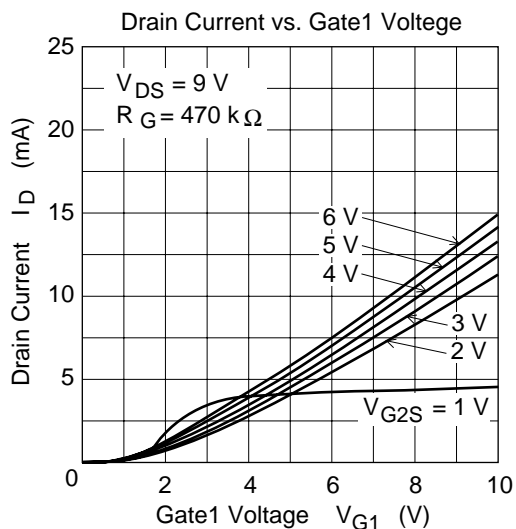

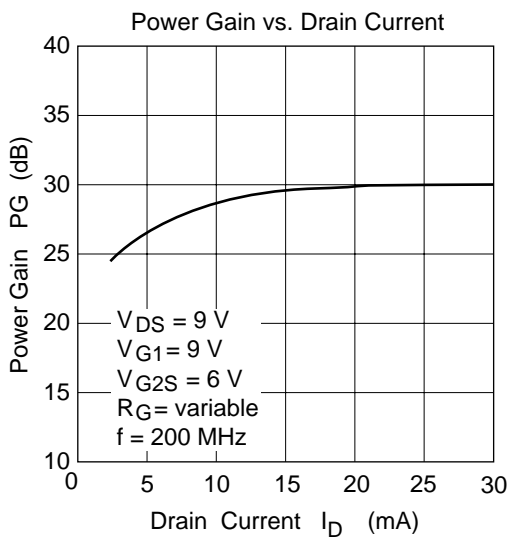
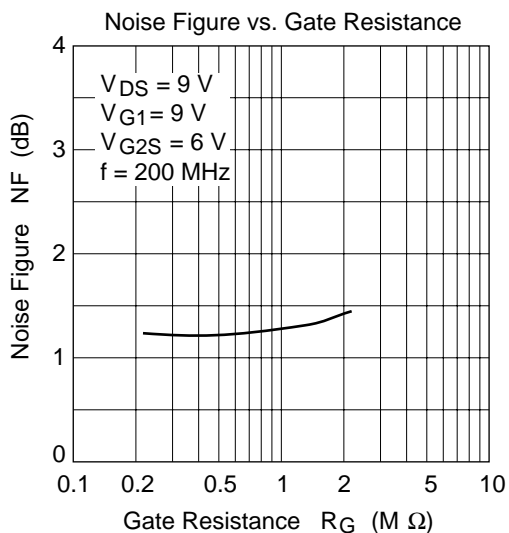
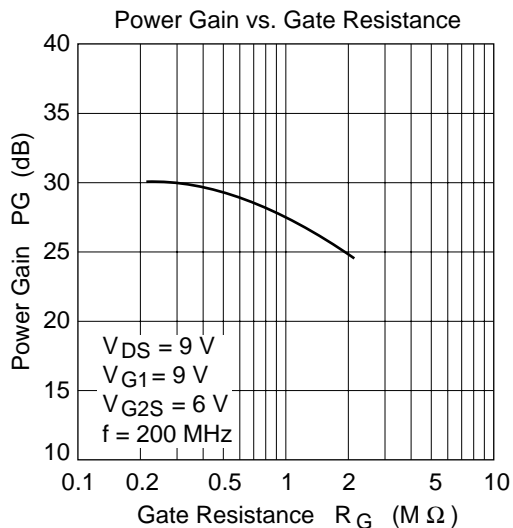
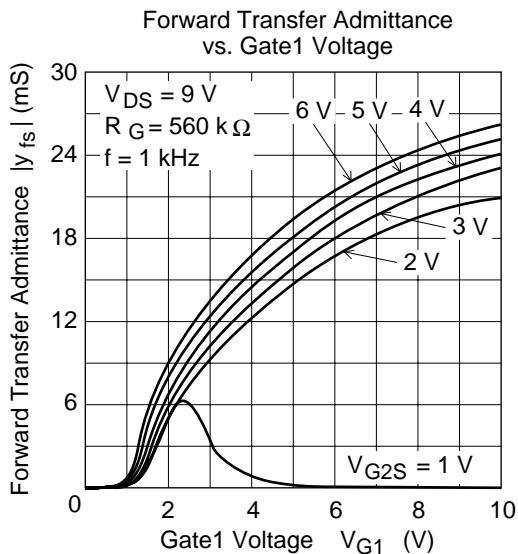

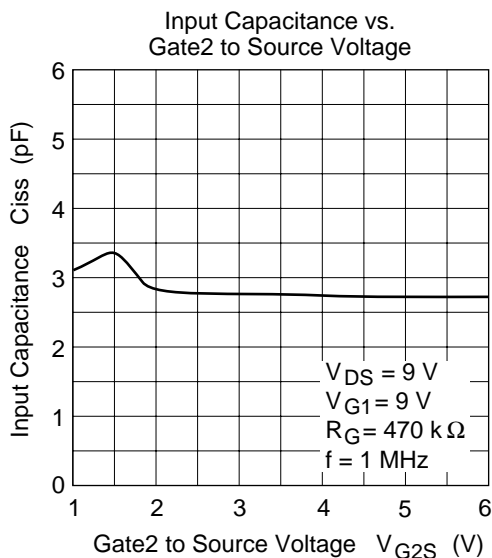
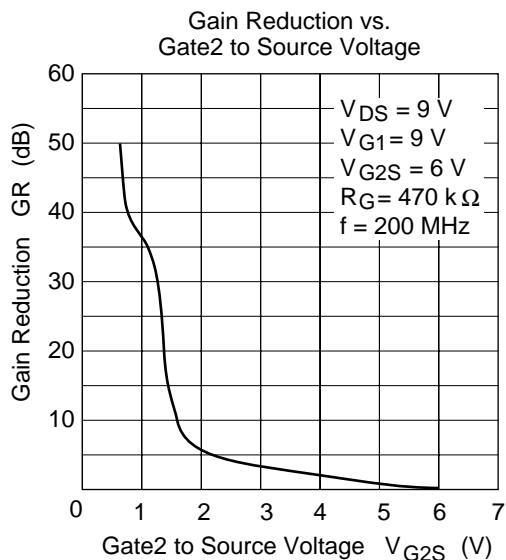
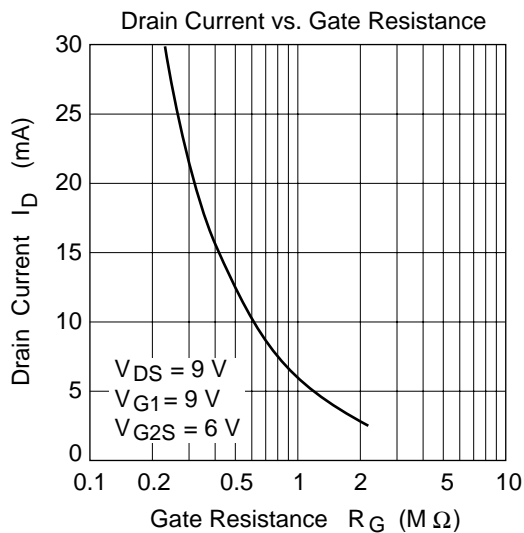
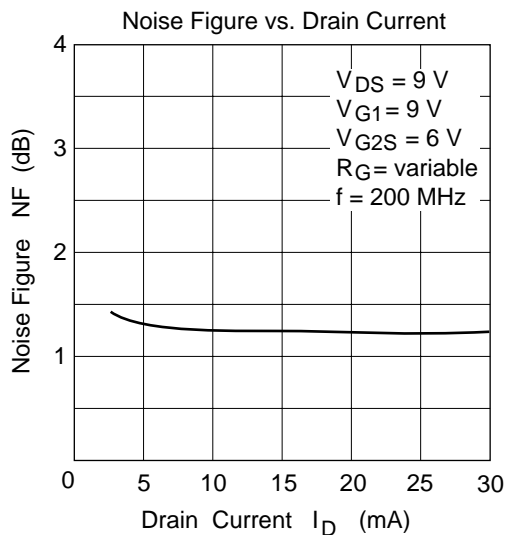

**S11 Parameter vs. Frequency**

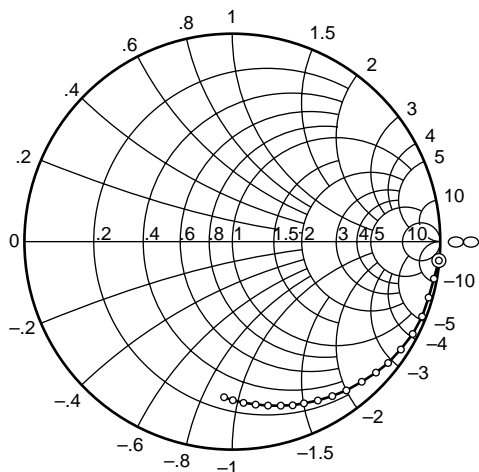

Test Condition :  $V_{DS} = 9\text{ V}$ ,  $V_{G1} = 9\text{ V}$   
 $V_{G2S} = 6\text{ V}$ ,  $R_G = 470\text{ k}\Omega$   
 50—1000 MHz (50 MHz step)



**S21 Parameter vs. Frequency**

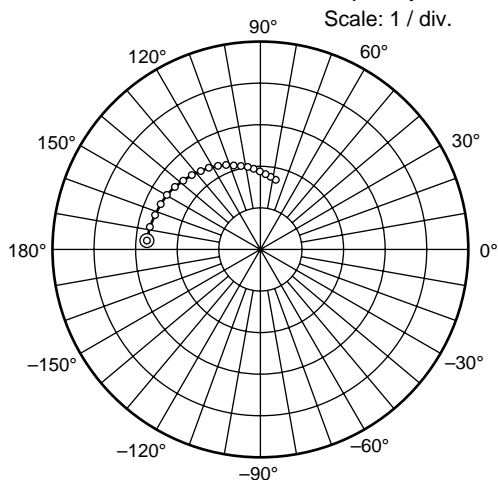

Test Condition :  $V_{DS} = 9\text{ V}$ ,  $V_{G1} = 9\text{ V}$   
 $V_{G2S} = 6\text{ V}$ ,  $R_G = 470\text{ k}\Omega$   
 50—1000 MHz (50 MHz step)



**S12 Parameter vs. Frequency**

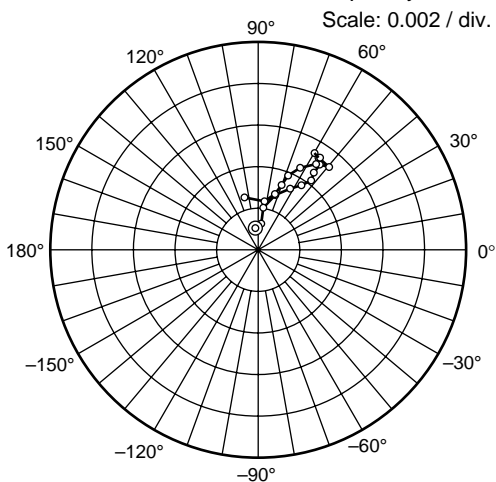

Test Condition :  $V_{DS} = 9\text{ V}$ ,  $V_{G1} = 9\text{ V}$   
 $V_{G2S} = 6\text{ V}$ ,  $R_G = 470\text{ k}\Omega$   
 50—1000 MHz (50 MHz step)



**S22 Parameter vs. Frequency**

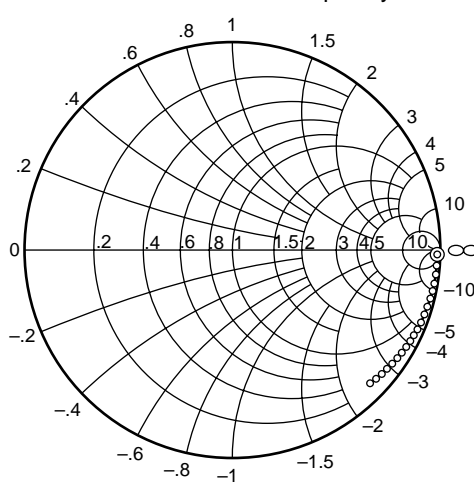

Test Condition :  $V_{DS} = 9\text{ V}$ ,  $V_{G1} = 9\text{ V}$   
 $V_{G2S} = 6\text{ V}$ ,  $R_G = 470\text{ k}\Omega$   
 50—1000 MHz (50 MHz step)



**Sparameter** ( $V_{DS} = V_{G1} = 9V$ ,  $V_{G2S} = 6V$ ,  $R_G = 470k\Omega$ ,  $Z_O = 50\Omega$ )

f (MHz)	S11		S21		S12		S22	
	MAG	ANG	MAG	ANG	MAG	ANG	MAG	ANG
50	0.996	-5.3	2.74	174.0	0.00096	98.6	0.985	-1.9
100	0.993	-10.9	2.73	168.0	0.00130	84.4	0.991	-4.5
150	0.987	-16.6	2.68	162.3	0.00203	83.6	0.990	-6.5
200	0.978	-21.9	2.66	156.3	0.00285	72.3	0.988	-9.4
250	0.972	-27.4	2.63	150.4	0.00335	69.7	0.985	-11.6
300	0.954	-33.2	2.57	144.3	0.00385	68.3	0.982	-14.0
350	0.943	-38.2	2.50	138.7	0.00455	63.2	0.979	-16.2
400	0.925	-43.2	2.43	133.3	0.00488	55.4	0.975	-18.4
450	0.910	-48.0	2.37	128.0	0.00526	59.8	0.971	-21.0
500	0.893	-52.5	2.30	122.6	0.00522	56.1	0.967	-23.0
550	0.880	-57.4	2.24	117.5	0.00498	53.2	0.962	-25.2
600	0.861	-62.1	2.17	112.7	0.00512	49.1	0.957	-27.3
650	0.847	-66.1	2.10	108.1	0.00497	53.4	0.952	-29.4
700	0.829	-69.9	2.02	103.6	0.00455	53.6	0.947	-31.6
750	0.816	-74.1	1.96	99.1	0.00418	51.6	0.943	-33.7
800	0.804	-78.2	1.91	94.8	0.00372	55.7	0.937	-35.8
850	0.791	-82.4	1.85	80.4	0.00329	62.4	0.933	-38.0
900	0.779	-86.1	1.79	86.3	0.00275	73.0	0.928	-40.0
950	0.764	-89.5	1.73	82.2	0.00233	82.4	0.921	-42.1
1000	0.753	-92.4	1.68	78.3	0.00258	105.1	0.918	-44.2



## Cautions

1. Hitachi neither warrants nor grants licenses of any rights of Hitachi's or any third party's patent, copyright, trademark, or other intellectual property rights for information contained in this document. Hitachi bears no responsibility for problems that may arise with third party's rights, including intellectual property rights, in connection with use of the information contained in this document.
2. Products and product specifications may be subject to change without notice. Confirm that you have received the latest product standards or specifications before final design, purchase or use.
3. Hitachi makes every attempt to ensure that its products are of high quality and reliability. However, contact Hitachi's sales office before using the product in an application that demands especially high quality and reliability or where its failure or malfunction may directly threaten human life or cause risk of bodily injury, such as aerospace, aeronautics, nuclear power, combustion control, transportation, traffic, safety equipment or medical equipment for life support.
4. Design your application so that the product is used within the ranges guaranteed by Hitachi particularly for maximum rating, operating supply voltage range, heat radiation characteristics, installation conditions and other characteristics. Hitachi bears no responsibility for failure or damage when used beyond the guaranteed ranges. Even within the guaranteed ranges, consider normally foreseeable failure rates or failure modes in semiconductor devices and employ systemic measures such as fail-safes, so that the equipment incorporating Hitachi product does not cause bodily injury, fire or other consequential damage due to operation of the Hitachi product.
5. This product is not designed to be radiation resistant.
6. No one is permitted to reproduce or duplicate, in any form, the whole or part of this document without written approval from Hitachi.
7. Contact Hitachi's sales office for any questions regarding this document or Hitachi semiconductor products.

# HITACHI

## Hitachi, Ltd.

Semiconductor & IC Div.  
Nippon Bldg., 2-6-2, Ohte-machi, Chiyoda-ku, Tokyo 100-0004, Japan  
Tel: Tokyo (03) 3270-2111 Fax: (03) 3270-5109

URL      NorthAmerica      : <http://semiconductor.hitachi.com/>  
             Europe                : <http://www.hitachi-eu.com/hel/ecg>  
             Asia (Singapore)        : <http://www.has.hitachi.com.sg/grp3/sicd/index.htm>  
             Asia (Taiwan)            : [http://www.hitachi.com.tw/E/Product/SICD\\_Frame.htm](http://www.hitachi.com.tw/E/Product/SICD_Frame.htm)  
             Asia (HongKong)        : <http://www.hitachi.com.hk/eng/bo/grp3/index.htm>  
             Japan                     : <http://www.hitachi.co.jp/Sicd/indx.htm>

## For further information write to:

Hitachi Semiconductor  
(America) Inc.  
2000 Sierra Point Parkway  
Brisbane, CA 94005-1897  
Tel: <1> (800) 285-1601  
Fax: <1> (303) 297-0447

Hitachi Europe GmbH  
Electronic components Group  
Dornacher Straße 3  
D-85622 Feldkirchen, Munich  
Germany  
Tel: <49> (89) 9 9180-0  
Fax: <49> (89) 9 29 30 00  
Hitachi Europe Ltd.  
Electronic Components Group.  
Whitebrook Park  
Lower Cookham Road  
Maidenhead  
Berkshire SL6 8YA, United Kingdom  
Tel: <44> (1628) 585000  
Fax: <44> (1628) 778322

Hitachi Asia Pte. Ltd.  
16 Collyer Quay #20-00  
Hitachi Tower  
Singapore 049318  
Tel: 535-2100  
Fax: 535-1533  
Hitachi Asia Ltd.  
Taipei Branch Office  
3F, Hung Kuo Building, No.167,  
Tun-Hwa North Road, Taipei (105)  
Tel: <886> (2) 2718-3666  
Fax: <886> (2) 2718-8180

Hitachi Asia (Hong Kong) Ltd.  
Group III (Electronic Components)  
7/F., North Tower, World Finance Centre,  
Harbour City, Canton Road, Tsim Sha Tsui,  
Kowloon, Hong Kong  
Tel: <852> (2) 735 9218  
Fax: <852> (2) 730 0281  
Telex: 40815 HITEC HX

Copyright © Hitachi, Ltd., 1998. All rights reserved. Printed in Japan.

This datasheet has been downloaded from:

[www.DatasheetCatalog.com](http://www.DatasheetCatalog.com)

Datasheets for electronic components.



LittleDiode supplies new, hard to find or obsolete electronic components and semiconductors all over the world.

With over two million different components listed you are sure to find the part you need.

Feel free to visit us today at our online store:

[LittleDiode.com](http://LittleDiode.com)

Looking forward to providing you with the best possible service.